

# AUTOMATIC CIRCLE BURNING AND WELDING ON PIPE AND PRESSURE VESSELS



Made in USA

No Hose or Cable Wrap-up Regardless of Direction of Rotation.  
Oxy-Fuel, Plasma Cutting and Welding Units Available.

Bug-O Systems is guided by honesty, integrity and ethics in service to our customers and in all we do.

**BUG-O SYSTEMS** CE  
A DIVISION OF WELD TOOLING CORPORATION

280 TECHNOLOGY DRIVE CANONSBURG, PENNSYLVANIA 15317-9564 USA  
PHONE: 412-331-1776 <http://www.bugo.com> FAX: 412-331-0383





# Bug-O Makes The ...

Wire reel adaptor for 30 lb. (13.6 kg) spools on the CW-5. 60 lb. (27 kg) wire reels included on the CW-7, CW-11 and CW-18.

Strong permanent magnet motor and gear train insure smooth movement of the welding torch.

For sub-arc applications, a 25 lb. (11 kg) capacity flux hopper is included on the CW-5AX, CW-7, CW-11 and CW-18.  
\*Flux Recover Available

Rise and fall cam, raises and lowers the torch to follow the contour of the pipe or vessel.

Welding gun and cable assembly included.

Racking groups for horizontal and vertical adjustment of the welding gun. Motorized racking is available.

Torch angle adjuster (optional on CW-5) standard on all other machines.

**Water cooled versions  
and electric oscillators  
are available upon request.**

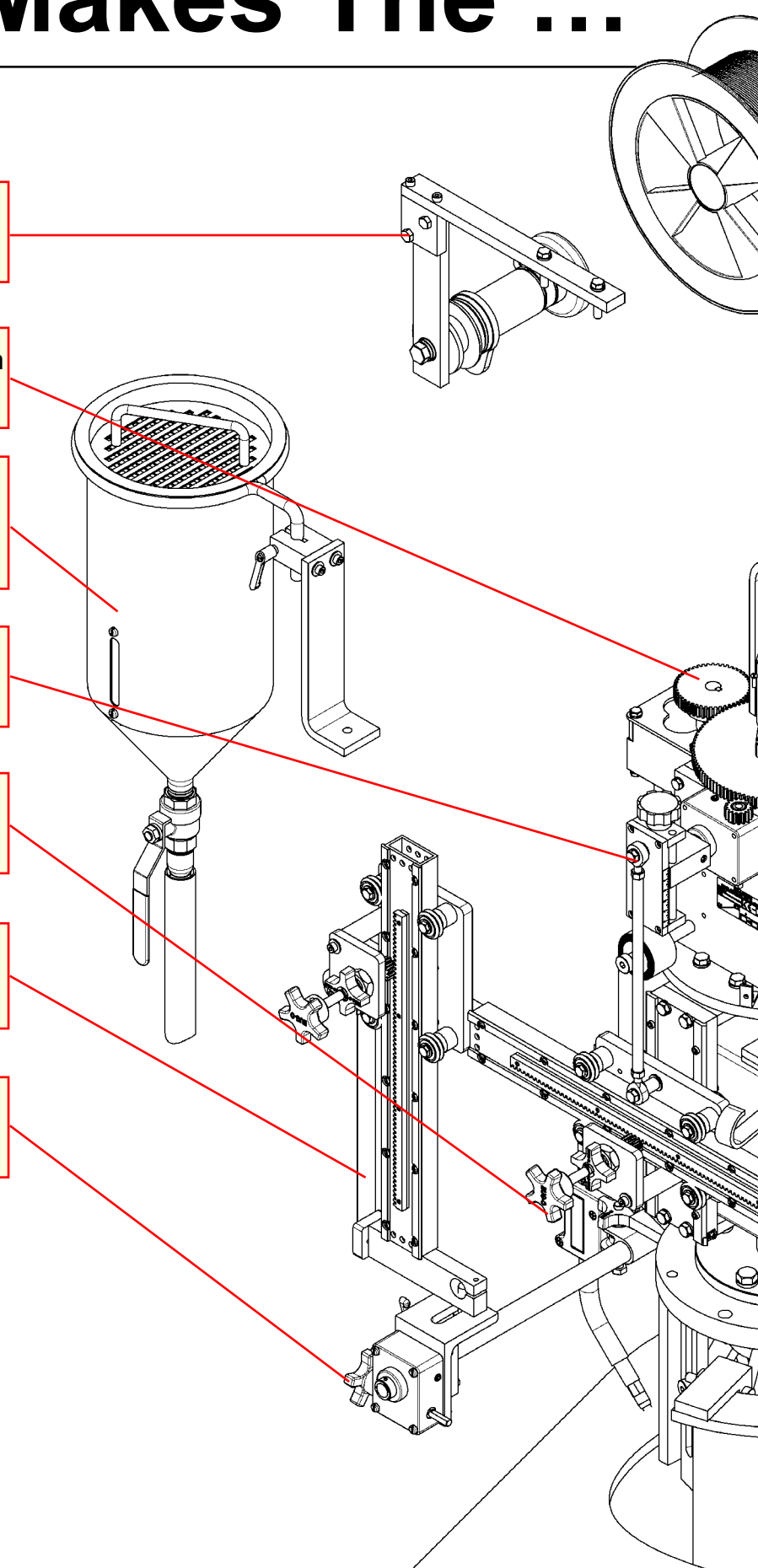



# Weld Go Round.

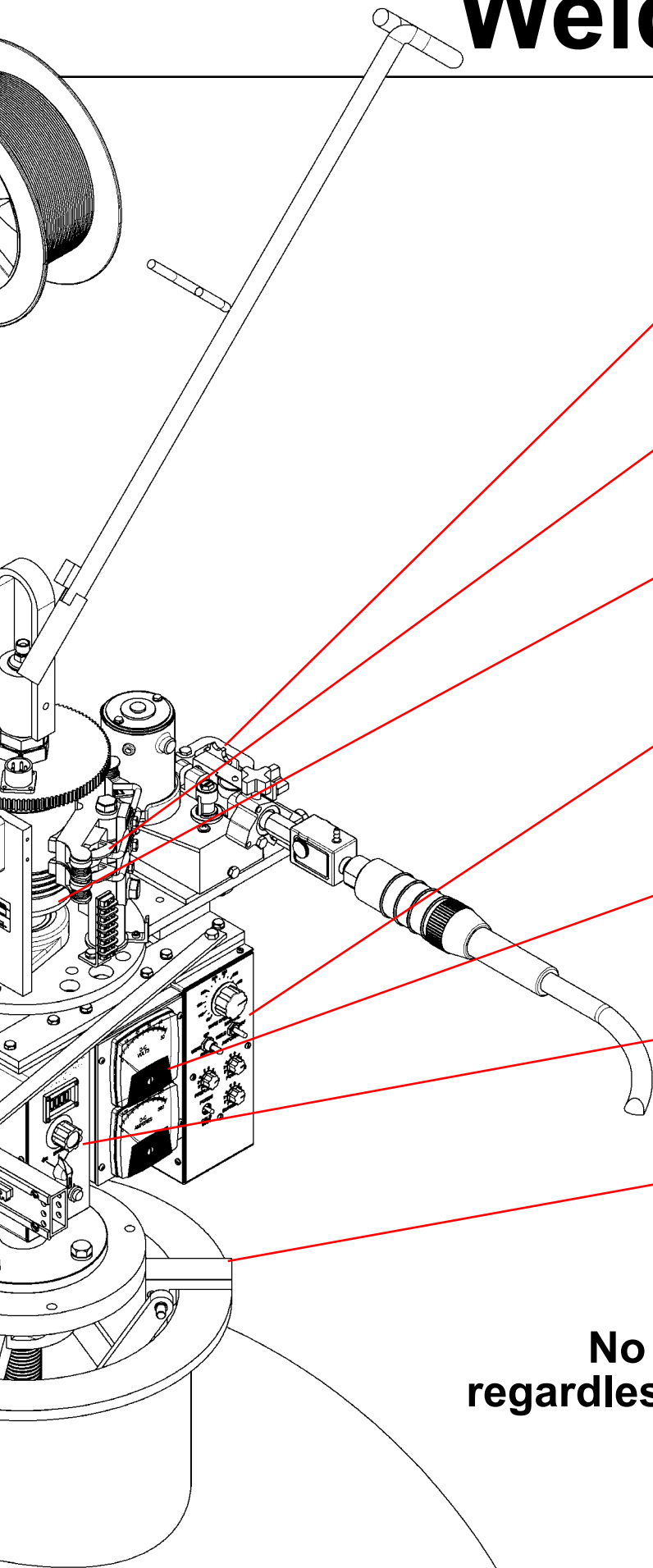

Wire feed motor.  
(See chart for wire sizes page 5)

Collector rings and brushes for welding current.\*

*\*Protective cover is removed for viewing of contents.*

Collector rings and brushes for rotation and controls.\*

Welding controls: manual/automatic weld/rotation switch, cold wire inch, purge switch, wire up-down switch, wire feed speed, burnback control and preflow-postflow times.

Volt meter and amp meter allow the welder to control the weld parameters at the machine. (Optional on the CW-5, included on all other models)

Rotation Speed Control.  
Direction and On-Off Switch.

3 jaw expandable chuck. (4 sizes available)  
Positions the machine on the nozzle.

**No hose or cable wrap-up  
regardless of the direction of rotation**



# Cypress Circle Welders - Standard

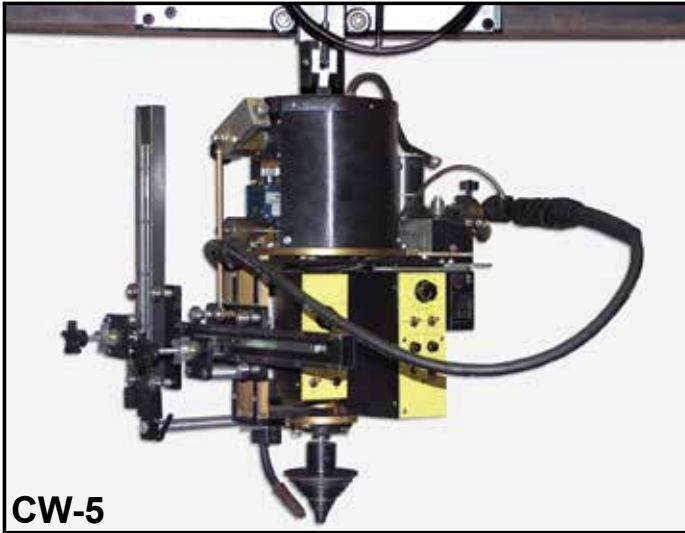

**CW-5**

The **CW-5 Circle Welder (CWO-1500)** is designed for single or multi-pass welding of couplings or nozzles on pipe and vessels utilizing MIG or Flux Core process, with gas shield. The machine is equipped with its own wire feeder, rotation drive motor, rise and fall cam assembly and welding gun. Horizontal and vertical racking to position the torch and a 30 lb (14 kg) spool holder. *For more detailed info. please see our "CW-5" tech sheet online at [bugo.com](http://bugo.com)*

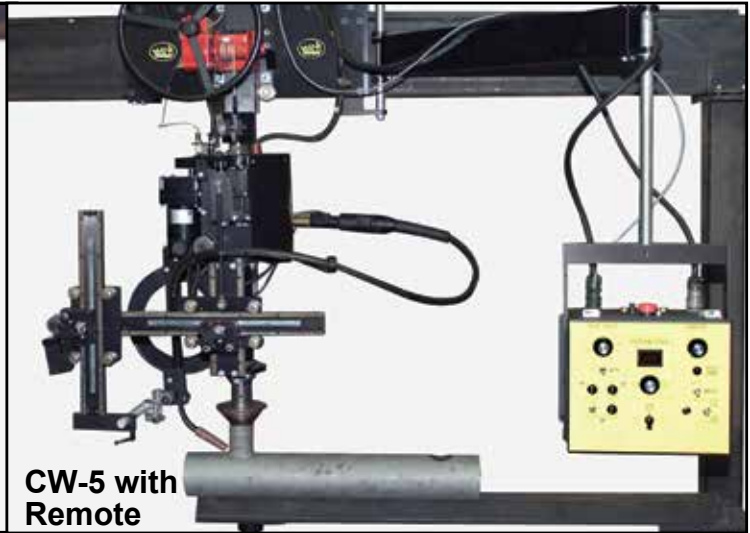

**CW-5 with Remote**

The **CW-5 with Remote Control (CWE-1500)** has a digital readout for rotation speed. It also has controls for: wire feed speed, cold inch/purge, pre-flow and post-flow, burn back and wire feeder forward and reverse. Overlap is also adjustable. This control has both manual and automatic settings. In the manual setting, you can check all your controls and travel speed to make sure the machine is functioning properly. In the automatic setting, with one push of a button, the unit will start the weld process, weld completely around the workpiece, overlap the end of the weld, turn the weld off and return to the start position. It is ready for the next weld. The CW-5 is supplied with the following cables: 50" (15.2 m) of gas hose, 50" (15.2 m) hot lead, 50" (15.2 m) control cable and all cables from the remote box to the circle welder. *For more detailed info. please see "CWE-1500" tech sheet online at [bugo.com](http://bugo.com)*



**CW-5AX**

The **CW-5AX Circle Welder (CWO-1560)** is designed for single pass or multi pass welding of couplings and nozzles on pipe and vessels. The unit is available for Sub Arc, MIG or Flux Cored process.

The CW-5AX offers all the same features as the CW-5 as well as a meter kit, torch angle adjuster and flux hopper. *For more detailed info. please see our "CW-5AX" tech sheet online at [bugo.com](http://bugo.com)*



**CW-7**

The **CW-7 Circle Welder (CWO-1700)** is equipped for MIG, Flux Core or Sub Arc welding on vessels and domed heads. The CW-7 has a working range of 6"-24" (152-610 mm) O.D. nozzles with no cable wrap up for multi-pass welding. This unit is capable of using welding wire sizes from .035"-3/32" (.8-2.4 mm).

The machine is equipped as shown and will carry 60 lbs. (27 kg) spools of wire. The unit is complete with wire feeder, gun and cable assembly, flux hopper, wire reel and meter kit. Mounts on 3-jaw chuck. (See chart on page 5 for welding capacities). *For more detailed info. please see our "CW-7" tech sheet online at [bugo.com](http://bugo.com)*



# Cypress Circle Welders - Standard



CW-11

The **CW-11 Circle Welder (CWO-1100)** is equipped for Sub-Arc, MIG and Flux Core welding on large vessels, domed heads and flat surfaces. The CW-11 has a working range of 10"-50" (254-1270 mm) O.D. nozzles with no cable wrap up for multi-pass welding. Remote control of amps and volts. The unit is capable of using welding wire diameters from .035"-3/32" (.8-2.4 mm). *For more detailed info. please see our "CW-11" tech sheet online at [bugo.com](http://bugo.com)*



CW-18

The **CW-18 Circle Welder (CWO-1800)** is designed for welding of nozzles into vessels or domed heads utilizing SUB-ARC. The CW-18 mounts on a 3-Jaw Chuck welding diameter 10" to 50" (152-1270 mm) O.D. It is capable of using welding wire diameters 3/32"-5/32" (2.4-4.0 mm). *For more detailed info. please see our "CW-18" tech sheet online at [bugo.com](http://bugo.com)*

## Circle Welder Capacities

Model	Process Capabilities	Welding Diameter*	Welding Wire Size	Rotation Speeds	Rise and Fall Cam	Rating amps	Standard Equipment
<b>CW-5</b> CWO-1500	MIG/MAG, FCAW	1-12" (25-300mm)	.035-1/16" (.8-1.6mm)	.5-6.0 rpm	0-5" (0-125mm)	300 amps 100% duty cycle	Burn back control, horizontal and vertical adjustment gun & cable
<b>CW-5</b> W/Remote CWE-1500							
<b>CW-5AX</b> CWO-1560	MIG/MAG, FCAW, SAW	1-12" (25-300mm)	.035-3/32" (.8-2.4mm)	.5-6.0 rpm	0-5" (0-125mm)	500 amps 100% duty cycle	Same as CW-5 plus: meter kit, torch angle adjuster, flux hopper, nozzle & cone.
<b>CW-5AX</b> W/Remote CWE-1560							
<b>CW-7</b> CWO-1700	MIG/MAG, FCAW, SAW	6-24" (150-600mm)	.035-3/32" (.8-2.4mm)	.2-2.2 rpm	0-7" (0-175mm)	500 amps 100% duty cycle	Burn back control, horizontal and vertical adjustment gun & cable.
<b>CW-7</b> W/Remote CWE-1700							
<b>CW-11</b> CWO-1100	MIG/MAG, FCAW, SAW	10-50" (254-1270mm)	Solid Wire .035-3/32" (.8-2.4mm) Flux Cored Wire .035-.120" (0.8-3.0mm)	.2-2.2 rpm	0-7" (0-175mm)	500 amp CO <sub>2</sub> 400 amp mixed gases 60% duty cycle	Burn back control, horizontal and vertical adjustment gun & cable.
<b>CW-18</b> CWO-1800	SAW	10-50" (254-1270mm)	Solid Wire 3/32-5/32" (2.4-4.0mm)	.2-2.2 rpm	0-7" (0-175mm)	1200 amps	Burn back control, horizontal and vertical adjustment gun & cable.

**\*NOTE:** Welding diameter capacities cannot exceed two thirds diameter of the workpiece.

When using a circle welder to weld a nozzle using the submerged arc process, it may be necessary that the customer employ some sort of external rolling device to ensure that the weld puddle and the associated flux be satisfactorily positioned. **5**



# Cypress Circle Welders with Rise & Fall Cam

## Accessories

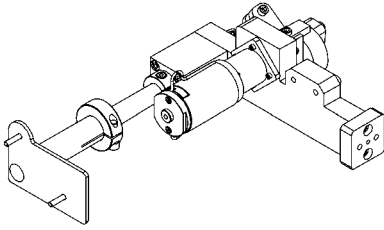

### **CWO-1645 Torch Weaver**

Provides a pendulum-type motion to the gun for weave welding. The speed and stroke of oscillation are adjustable.

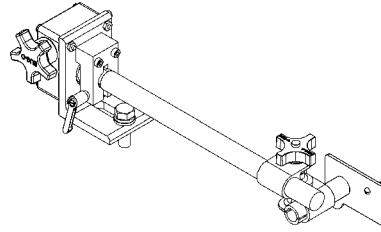

### **CWO-3023-1 Torch Angle Adjuster**

Allows the operator to adjust the angle of the gun precisely, without unclamping the holding device.

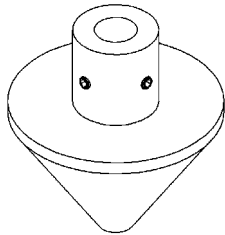

### **CWO-5790 Cone Adaptor**

A tapered centering device used to center the machine on nozzles. The range of the Cone Adaptor is 1-1/4" to 4" (32-102 mm) diameter.

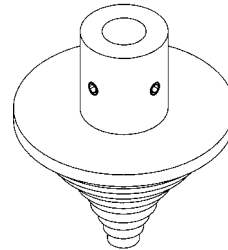

### **CWO-3670 Step Adaptor for Threaded Outlets**

A stepped centering device used to center the machine on threaded I.D. weld-o-lets. The range of the Step Adaptor is 1/2" to 4" (13-102 mm) diameter.

### **CWO-3675 Step Adaptor for Grooved Outlets**

1 1/4" - 1 1/2" - 2" - 2 1/2" - 3", 4"

## Chucks



### **CWO-3660 Lathe Chuck**

2"-10" (50-254mm) lathe chuck for small fittings and nozzles.



### **3-Jaw Expandable Chuck**

Mounts and automatically centers the Circle Welder on nozzles with or without flanges. For use with all circle welders.

PART NO.	FOR NOZZLE I.D.'s	WEIGHT
CWO-3660	2"-10" (50-254 mm)	69 lbs. (31.3 kgs)
CWO-3661	8"-16" (204-405 mm)	36 lbs. (16 kgs)
CWO-3662	10"-24" (255-610 mm)	51 lbs. (23 kgs)
CWO-3663	24"-42" (610-1065 mm)	64 lbs. (29 kgs)





# Cypress Circle Welders with Rise & Fall Cam

## Carriages

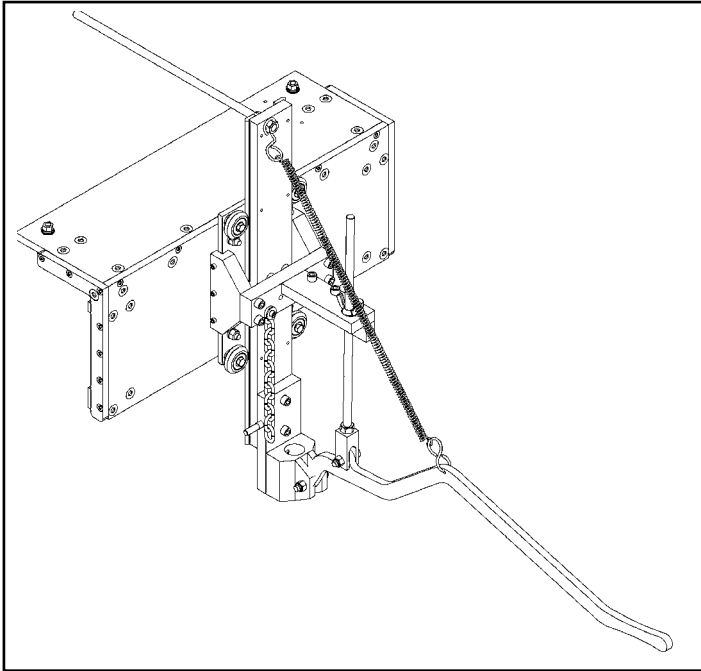

### CWO-4530 Carriage

May be used only with CW-5 CIRCLE WELDERS. The carriage, which is mounted on a standard monorail, is used to move the welder along a length of pipe.

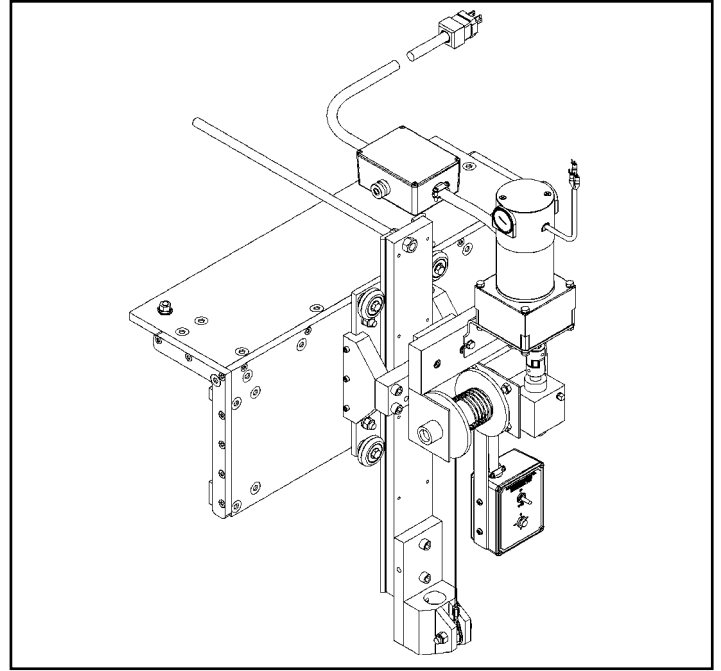

### CWO-4550 Motorized Carriage\*

May be used with either the CW-5 CIRCLE WELDER or the CB-1P AIR PLASMA MACHINE. Provides motorized vertical travel of the machine.

\*New **CWE-4550 Motorized Carriage** is available for use with CWE models.

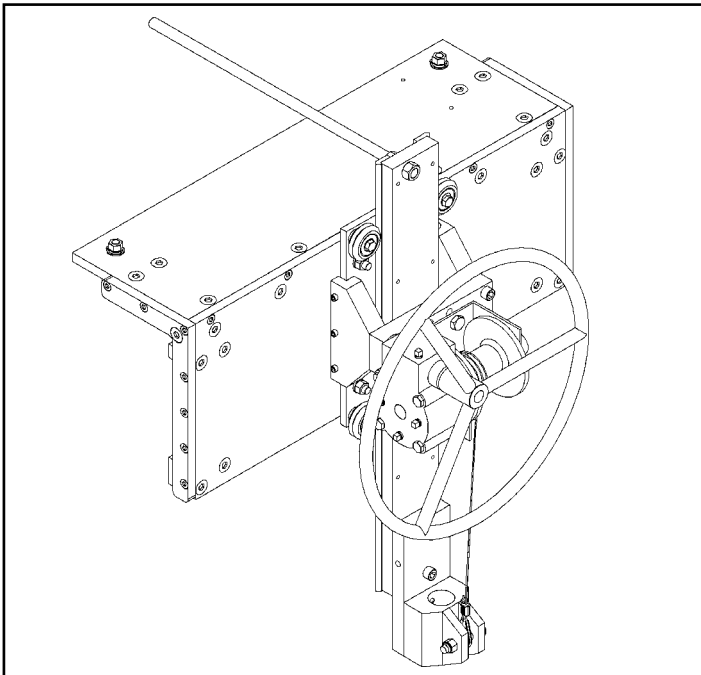

### CWO-4540 Carriage

This carriage, which is mounted on a standard monorail, is used with the CB-1P AIR PLASMA MACHINE. A winch holds the machine and prevents the machine from falling into the hole when the slug drops. This carriage may also be used with CW-5 CIRCLE WELDERS.

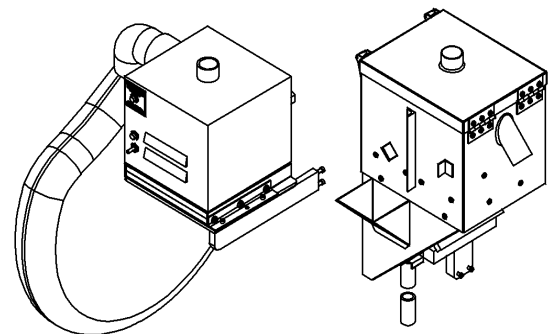

### Submerged Arc Flux Recovery System

**CWO-2020 120 volt**

**CWO-2025 240 volt**

Continuously removes and recycles all unused flux. Available on any CW-5AX, CW-7, CW-11 and CW-18.

### Pneumatic Flux Recovery System

**CWO-2020-AP**

Continuously removes and recycles all unused flux. Available on any CW-5AX, CW-7, CW-11 and CW-18.



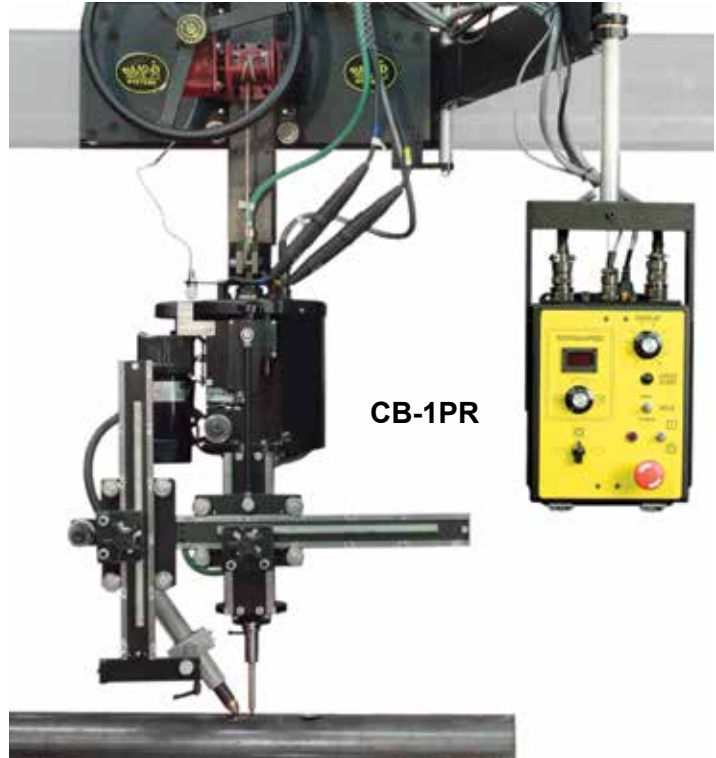
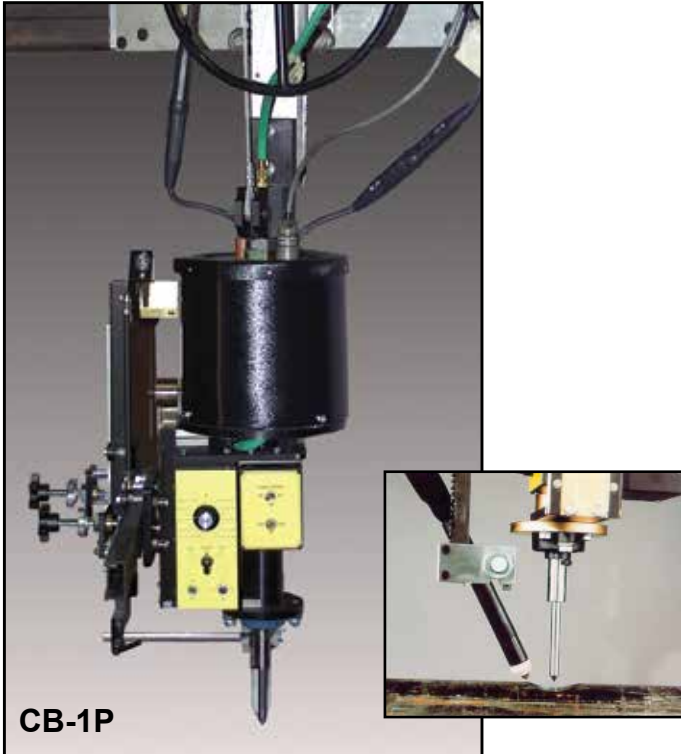

# Cypress Circle Burners with Rise & Fall Cam



The **CB-1P Plasma Circle Burner (CBO-1020)** is designed for cutting beveled holes in lightwall pipe or vessels. This machine is supplied with an air plasma power source (that customer specifies), torch and 50' (15 m) leads. The CB-1P must be mounted on a carriage or fixture. *For more detailed information please see our "CB-1P" tech sheet online at [bugo.com](http://bugo.com)*

The **CB-1PR Plasma Circle Burner with Remote Control (CBP-2020)** is designed for cutting beveled holes in lightwall pipe or vessels. This machine is supplied with an air plasma power source (that customer specifies), torch and 50' (15 m) leads. The CB-1PR must be mounted on a carriage or fixture.

Victor / Thermal Dynamics Cutmaster Series / A Series		Hypertherm Powermax Series		
	<i>Example: Cutmaster 82</i> Auto voltage runs on 200-600 Volts, 1 or 3-phase, without the need of rewiring.	<b>Power Requirements</b>	<i>Example: Powermax 85</i> Auto voltage runs on 200-600 Volts, 1 or 3-phase, without the need of rewiring.	
	20-80 Amps		<b>Adjustable Output Current</b>	25-85 Amps
	(Recommended) 3/4" (19 mm) Max		<b>Cutting Capacity</b>	(Recommended) 3/4" (19 mm) Max
				





# Cypress Circle Burners with Rise & Fall Cam

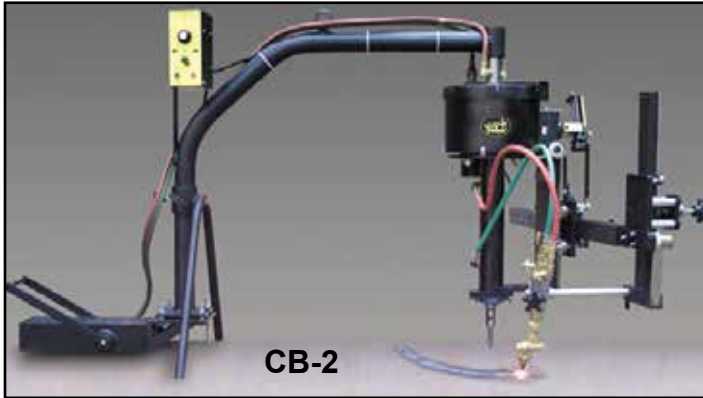

The **CB-2 Circle Burner (CBO-2000)** uses Oxy-fuel for square or beveled hole cuts (see chart for capacities). The CB-2 is mounted on a special frame with a releasable permanent magnet base. Machine includes variable speed rotation, 2-hose Oxy-fuel machine torch, adjustable tip adaptor, vertical and horizontal torch adjustment and rise and fall cam. *For more detailed information please see our "CB-2" tech sheet online at [bugo.com](http://bugo.com)*

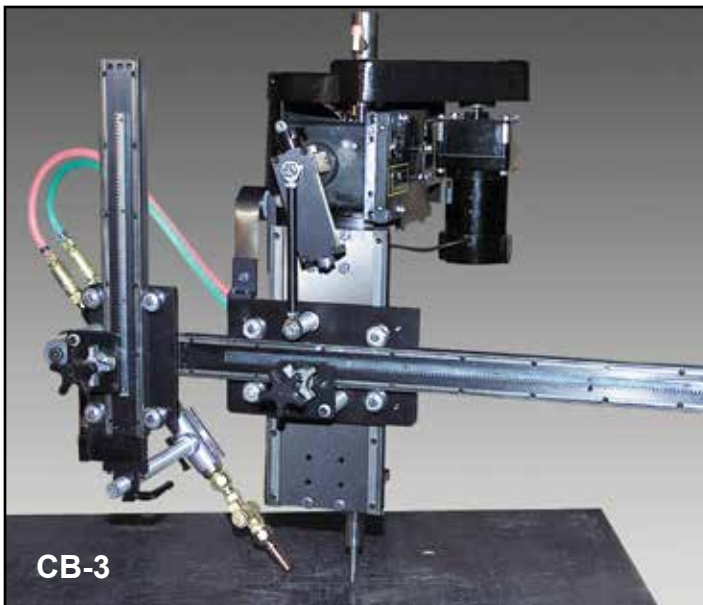

The **CB-3 Circle Burner (CBO-3000)** uses Oxy-fuel for square or beveled hole cuts (see chart for capacities). Unit includes 2-hose Oxy-fuel machine torch, adjustable tip adaptor, variable speed rotation, vertical and horizontal torch adjustment and rise and fall cam. The CB-3 must be mounted on a column and boom, manipulator or fixture. *For more detailed information please see our "CB-3" tech sheet online at [bugo.com](http://bugo.com)*

## Circle Burner Capacities

Model	Burning Diameter*	Mounting	Process	Rise and Fall Cam	Net Weight	Use
<b>CB-2</b> CBO-2000	1.5"-42" beveled holes (38-1067 mm) 4"-48" square cut (102-1219 mm)	Manually Operated Magnet	Oxy-fuel	0-7" (0-178 mm)	225 lbs. (102 kg)	vessels, large diameter pipe
<b>CB-3</b> CBO-3000	1.5"-42" beveled holes (38-1067 mm) 4"-48" square cut (102-1219 mm)	Carriage or Manipulator	Oxy-fuel	0-7" (0-178 mm)	170 lbs. (77 kg)	domed heads, vessels, large
<b>CB-1P</b> CBO-1020	.5"-12" beveled holes (13-305 mm)	Carriage or Manipulator	Plasma	5" (127 mm)	170 lbs. (77 kg)	Thin wall, small diameter pipe
<b>CB-1P W/ Remote</b> CBP-2020	.5"-12" beveled holes (13-305 mm)	Carriage or Manipulator	Plasma	5" (127 mm)	170 lbs. (77 kg)	Thin wall, small diameter pipe

\*NOTE: Burning diameter cannot exceed two thirds diameter of the workpiece.



# Specials - Cypress Circle Welders

Bug-O addresses the need to utilize the latest advancements in pulsed MIG and submerged arc process control for its circle welders. These Circle Welder Systems are now available for Digitally Controlled Welding Power Sources. All digital control signals can now be passed to a continuously turning wire feeder for high efficiency submerged arc, thick wall, nozzle to vessel welds. Now you can have all the power and arc characteristics that the new digital control power sources can deliver, along with no hose or cable wrap-up regardless of direction or rotation.



The **DCW-18-L Circle Welder**, equipped with Lincoln Electric® MAXsa® 10 Controller for Power Wave® AC/DC 1000® is capable of welding nozzles with a diameter range of 10-50 inch diameter. The machine is set up for sub arc process. Features of the machine include Eight procedure memories and user friendly controls.



The **DCW-5-L Circle Welder**, equipped with Lincoln Electric® Power Feed 84® wire feeder, is capable of welding 1-12" (25.4-304.8 mm) diameters. This machine can be used for MIG, pulsed MIG and flux cored welding process. There are eight user memories for complete welding procedure recall, and preprogrammed auto settings to simplify process procedures.



The **DCW-18-M Circle Welder**, equipped with Miller® Digital interface for use with Miller® Digital series power sources . It is capable of welding nozzle diameters from 10-50" and is set up for sub arc process.



The **DCW-5-O Circle Welder**, equipped with OTC-DAIHEN AF-4012 wire feeder, provides OTC patented wave pulse process. 1"-12" (25.4-304.8 mm) diameter range.



The **CWE-5 with Tripod**, allows you to weld or cut circles on a flat plate using a mobile tripod to position the machine in the proper location.



# Specials - Cypress Circle Welders



The **CWP-5 Programmable Circle Welder** is designed for single or multi-pass welding of couplings or nozzles utilizing MIG or Flux Core process capable of welding 1-12" (25-305 mm) diameters.

The **CWP-5AX Programmable Circle Welder** is designed for single or multi-pass welding of couplings or nozzles utilizing Sub-Arc, MIG or Flux Core process capable of welding 1-12" (25-305 mm) diameters.

The **CWP-7 Programmable Circle Welder** is equipped for MIG, Flux Core or Sub-Arc welding on vessels and domed heads. The CW-7 has a working range of 6-24" (152-610 mm) O.D. nozzles with no cable wrap up for multi-pass welding.

These machines use a microprocessor to control the rise and fall through encoder position. They are capable of using welding wire sizes from .035-3/32" (.8-2.4 mm). Please refer to the chart on page 11 for additional information.



The **CWP-18 Programmable Circle Welder** is designed for single or multi-pass welding of couplings or nozzles into vessels or domed heads utilizing Sub-Arc, MIG or Flux Core process with gas shielding. The CWP-18 mounts on a 3 jaw chuck for welding diameters of 10-50" (254-1270 mm) O.D.



The **CWP-11 Programmable Circle Welder** is designed for welding of nozzles into vessels utilizing Sub-Arc, MIG or Flux Cored Process. The CWP-11 mounts on a 3-Jaw Chuck for welding diameter 6-50" (152-1270 mm) O.D.

Model	Process Capabilities	Welding Diameter	Welding Wire Size	Rotation Speeds	Rise / Fall	Rating amps	Standard Equipment
<b>CWP-5</b>	MIG/MAG, FCAW	1-12" (25-305mm)	.035-1/16" (.8-1.6mm)	.5-6.0 rpm	CNC Controlled	300 amps 100% duty cycle	Burn back control, horizontal and vertical adjustment gun & cable
<b>CWP-5AX</b>	MIG/MAG, FCAW, SAW	1-12" (25-305mm)	.035-3/32" (.8-2.4mm)	.5-6.0 rpm	CNC Controlled	500 amps 100% duty cycle	Same as CW-5 plus: meter kit, torch angle adjuster, flux hopper, nozzle & cone
<b>CWP-7</b>	MIG/MAG, FCAW, SAW	6-24" (150-610mm)	.035-3/32" (.8-2.4mm)	.2-2.2 rpm	CNC Controlled	500 amps 100% duty cycle	Burn back control, horizontal and vertical adjustment gun & cable
<b>CWP-11</b>	MIG/MAG, FCAW, SAW	10-50" (254-1270mm)	Solid Wire .035-3/32" (.8-3.0mm)  Flux Cored Wire .068-.120" (1.7-3.0mm)	.2-2.2 rpm	CNC Controlled	500 amp CO <sub>2</sub> 400 amp mixed gasses 60% duty cycle	Burn back control, horizontal and vertical adjustment gun & cable
<b>CWP-18</b>	SAW	10-50" (254-1270mm)	Solid Wire 3/32-7/32" (2.4-5.6mm)	.2-2.2 rpm	CNC Controlled	1200 amps	Burn back control, horizontal and vertical adjustment gun & cable





# Specials - Cypress Circle Burners

## Capabilities

Saddle Welds	Partial Offset Saddle Welds	Full Offset Saddle Welds
<p align="center"><b>Programmable or Standard</b></p>	<p align="center"><b>Programmable Only</b></p>	<p align="center"><b>Programmable or Standard with Hillside Kit</b></p>
<p><b>Axes In-line:</b></p> <p>When the axes of the tube are in-line with each other, a standard machine with a mechanical cam will provide two equal rise and fall motions to follow the contour of the weld.</p>	<p><b>Axes offset, small tube still passes through the center of main tube:</b></p> <p>When the axes of the tubes are offset, but the small tube still passes over the center-line of the large tube, the contour of the weld is one small rise and fall and one larger rise and fall. The tube diameter and the off-set distance are entered into a program. The resulting contoured travel is calculated as part of the program. All motion is motorized and encoder controlled.</p>	<p><b>Axes offset, small tube completely off center of main tube axes:</b></p> <p>When the axes of the tubes are offset so far that the small tube is completely outside the main tubes center-line. A standard machine with a hillside adapter kit will produce the single rise and fall motion required to follow the contour of the weld.</p>

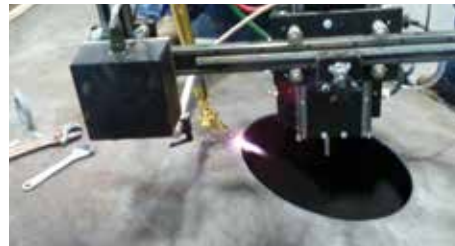
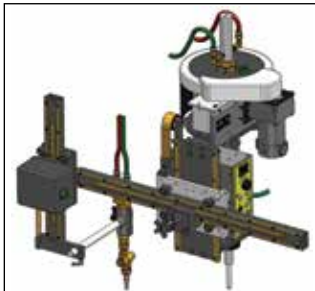

The **CBP-3 Programmable Circle Burner** must be mounted on a column and boom, manipulator or fixture. Uses Oxy-fuel for square or beveled hole cuts (see chart for capacities).

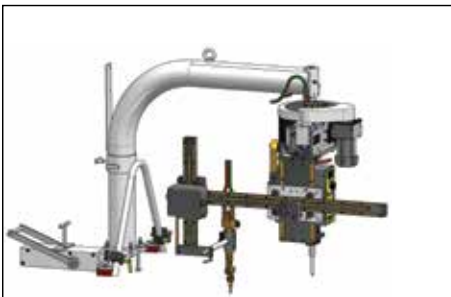

The **CBP-4 Programmable Circle Burner** is mounted on a special frame with a releasable permanent magnet base. Uses Oxy-fuel for square or beveled hole cuts (see chart for capacities).

## Programmable Circle Burner Capacities

Model	Burning Diameter	Mounting	Process	Rise and Fall Cam	Net Weight	Use
<b>CBP-3 CBP-3000</b>	1.5"-42" beveled holes (38-1067 mm) 4"-48" square cut (102-1219 mm)	Carriage or Manipulator	Oxy-fuel	0-7" (0-178 mm)	170 lbs. (77 kg)	domed heads, vessels, large
<b>CBP-4 CBP-4000</b>	1.5"-42" beveled holes (38-1067 mm) 4"-48" square cut (102-1219 mm)	Manually Operated Magnet	Oxy-fuel	0-7" (0-178 mm)	225 lbs. (102 kg)	vessels, large diameter pipe



# Cypress Saddle and Elbow Cutters

The **MM1 Programmable Pipe Cutter (SEO-3500)** is a computer controlled machine that automates the cutting of profiles, holes and shapes on pipe with diameters from 4"-16" (102-406 mm). It rotates the pipe on it's roller bed with a three jaw chuck while simultaneously moving a cutting torch back and forth along the pipe's axis. Pre-programmed shapes such as saddle, hillside, lateral and miter cuts can be made by simply selecting the type of cut from the menu, then entering the diameters of the pipes being processed and pressing the run button to cut your pipe.

\*Oxy-fuel versions are available.

\*Optional: Machine cutting capacity can be increased to 24" (610 mm) diameter at factory.

For more detailed information please see "MM1 Programmable Pipe Cutter" brochure online at [bugo.com](http://bugo.com)

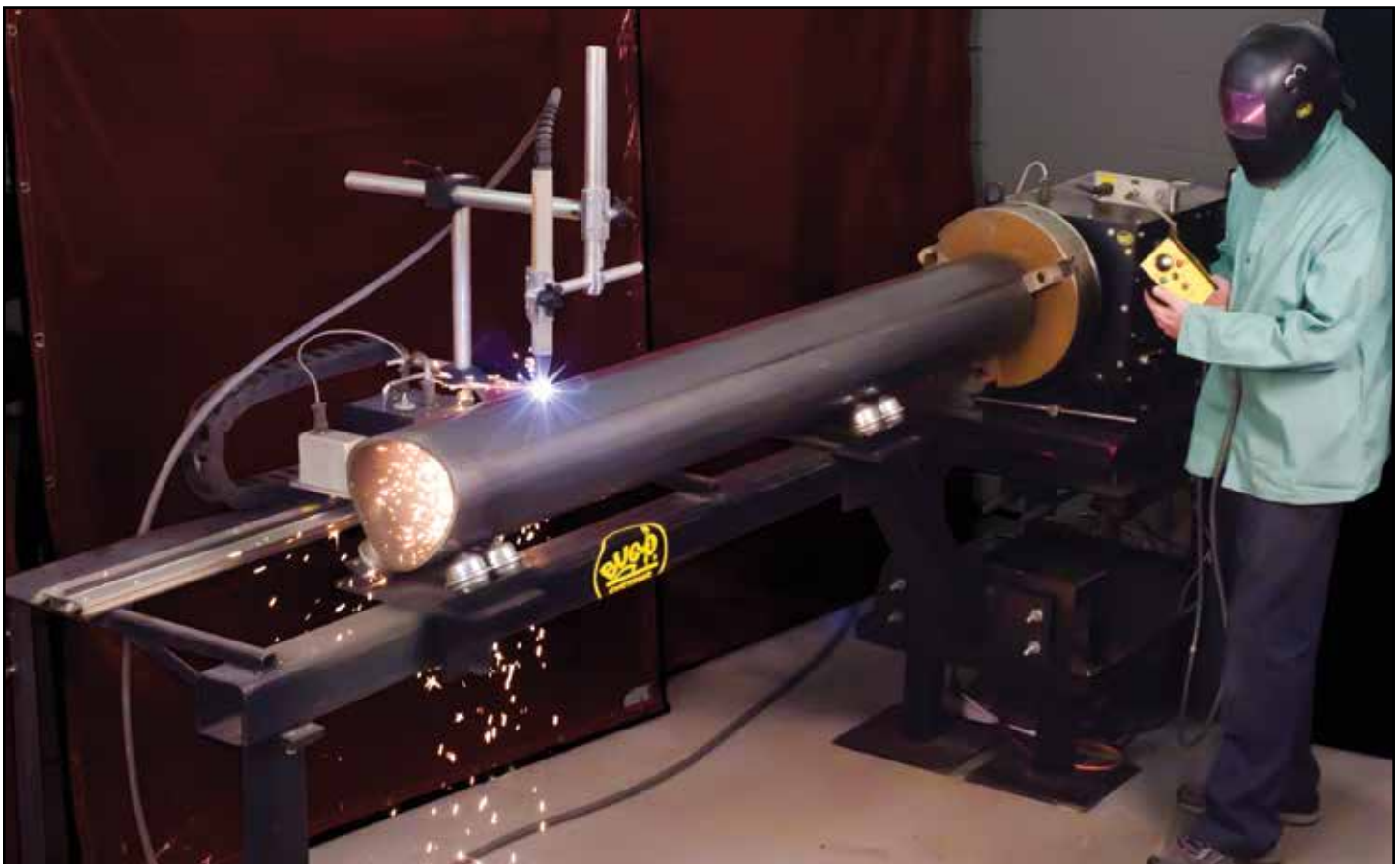
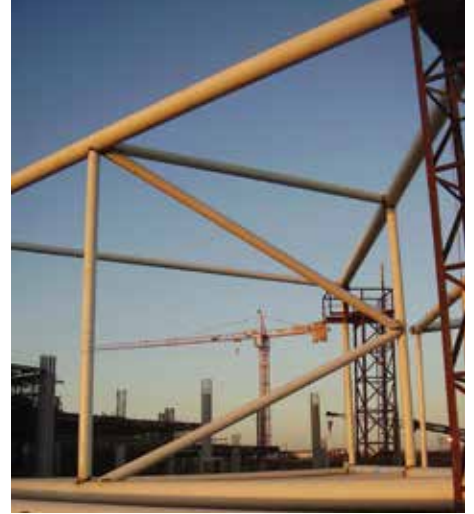



# Cypress Saddle and Elbow Cutters

The **SE-2PTD Programmable Pass Through Pipe Cutting Machine** is used to cut saddles, offset saddles, laterals, miter cuts and holes on pipe. A second (selectable) program is used for cutting customized shapes in pipe. There is also Windows based software available for programming. This machine can be configured for oxy-fuel, plasma or both. The SE-2PTD eliminates the need to make templates or to layout complex cuts. See the chart below for machine capacities.

## SE-2PTD

SEO-4250-OX Oxy-fuel Version

SEO-4250-PL Plasma Version

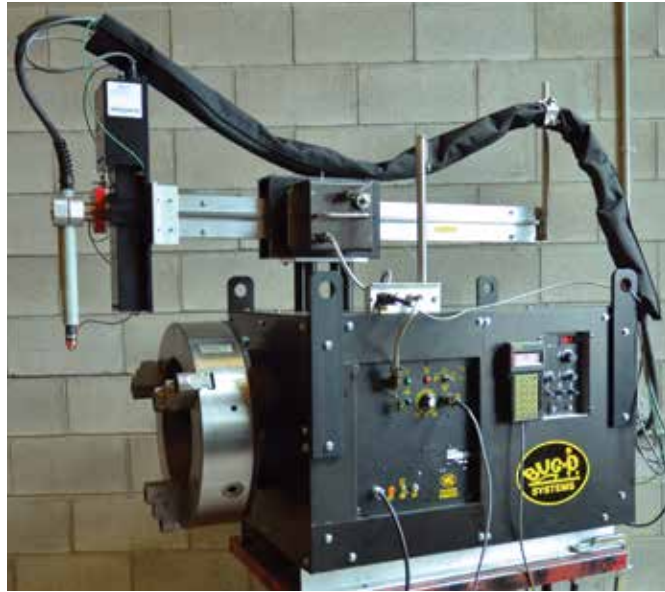
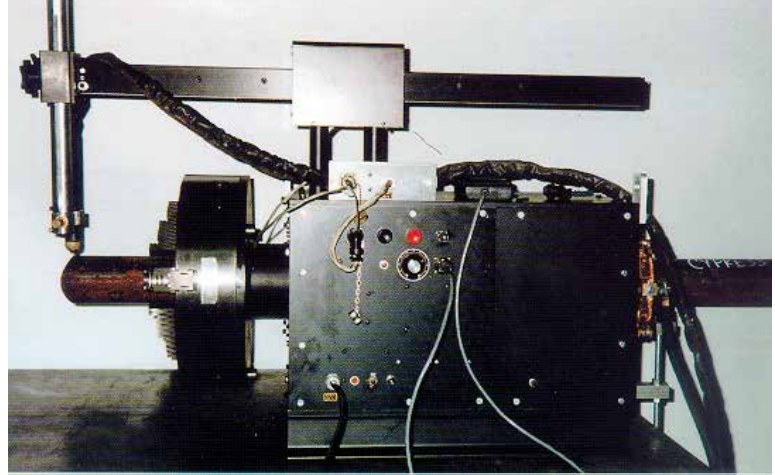

The **SE-4PTD Programmable Pass Through Pipe Cutting Machine** is used to cut saddles, offset saddles, laterals, miter cuts and holes on pipe. A second (selectable) program is used for cutting customized shapes in pipe. There is also Windows based software available for programming. This machine can be configured for oxy-fuel, plasma or both. The SE-4PTD eliminates the need to make templates or to layout complex cuts. See the chart below for machine capacities.

## SE-4PTD

SEO-4400-OX Oxy-fuel Version

SEO-4400-PL Plasma Version

The SE-4PTD pictured to the left has been custom designed and integrated with the following items:

- Heavy Duty Linear Drive and Cross Arm
- Recessed Control Panel
- Hypertherm Automatic Height Control

**NOTE:** SEO series machines do not include torch or plasma machine.

For more detailed information please see "SE-4PD, SE-2PTD & SE-4PTD" brochure online at [bugo.com](http://bugo.com)

SADDLE AND ELBOW CUTTER CAPACITIES	Model	Process	Pass Through	Pipe Diameter Range	Speed Rotation	Range of Pipe Lengths that can be Cut
	SE-2PTD	Plasma or Oxy-fuel	1" - 4" (25 - 102 mm)	1" - 14" (25 - 356 mm)	.3 3.7 rpm	3"-18" (76 - 457 mm)
	SE-4PD	Plasma or Oxy-fuel	N/A	1" - 12" (25 - 305 mm)	.3 3.7 rpm	3"-18" (76 - 457 mm)
	SE-4PTD	Plasma or Oxy-fuel	4" - 12 3/4" (102 - 324 mm)	4" - 20" (102 - 508 mm)	.2 3 rpm	3"-20" (76 - 508 mm)
	MM1	Plasma or Oxy-fuel	N/A	Standard Machine 4"-16" (102 - 406 mm) Optional 4"-24" (102 - 610 mm)	.2 3 rpm	3"-38 ft. (76 mm - 11.6 m)





# Cypress Saddle and Elbow Cutters

## Capabilities

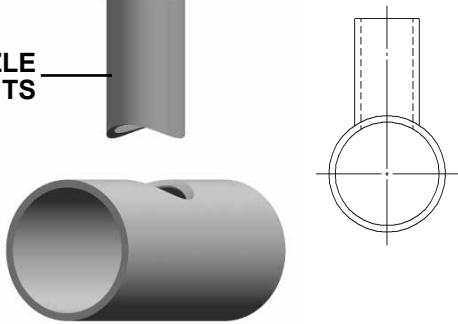
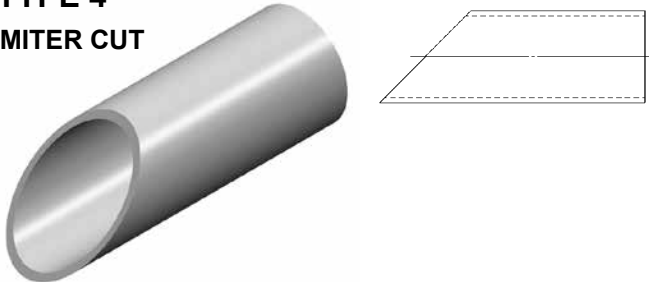
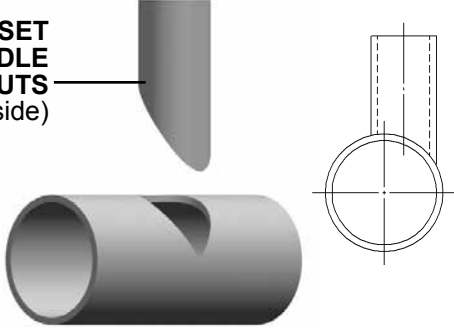
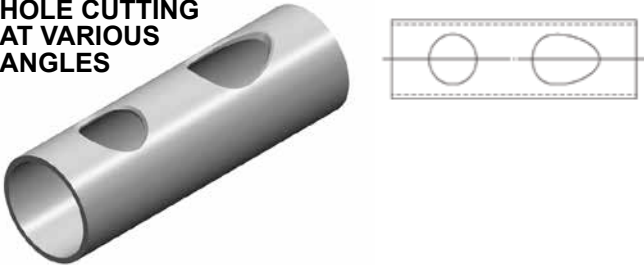
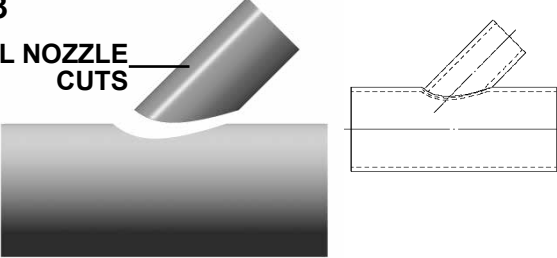
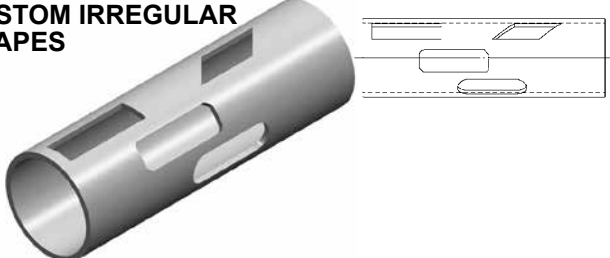
<p><b>TYPE 1</b> SADDLE NOZZLE CUTS</p> 	<p><b>TYPE 4</b> MITER CUT</p> 
<p><b>TYPE 2</b> OFFSET SADDLE NOZZLE CUTS (Hillside)</p> 	<p><b>TYPE 5</b> HOLE CUTTING AT VARIOUS ANGLES</p> 
<p><b>TYPE 3</b> LATERAL NOZZLE CUTS</p> 	<p><b>SHAPE PROGRAM</b> CUSTOM IRREGULAR SHAPES</p> 

## Hand Held Terminal:

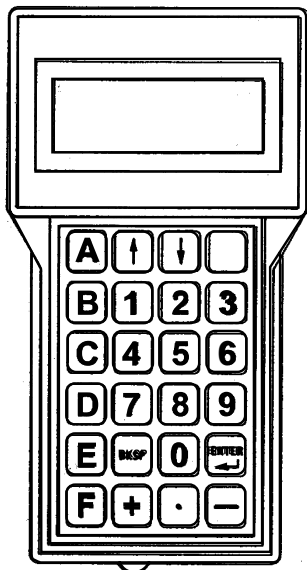

### Example: Programming Sequence for Type 3 Cut.

1. Press the reset button on the machine. The hand held terminal will display "READY".
  2. Press "A" on the terminal. The terminal will ask you what type of cut you want. (See Types 1-5).
  3. Press the number desired and then press "ENTER".
  4. The terminal will ask for the diameter of the small pipe. Press the appropriate dimensions and press "ENTER".
  5. The terminal will ask for the diameter of the large pipe. Press the appropriate dimensions and press "ENTER".
  6. Enter the offset dimension.
  7. Enter the "ANGLE" in degrees.
  8. Press "START" on the machine to begin the cut. It couldn't be easier!
- When using Plasma, press "B" and enter the time delay required (which is stored until changed again).



# Cypress Sprinkler Fabrication Equipment



## TYPICAL SET UP FOR SPRINKLER FABRICATION

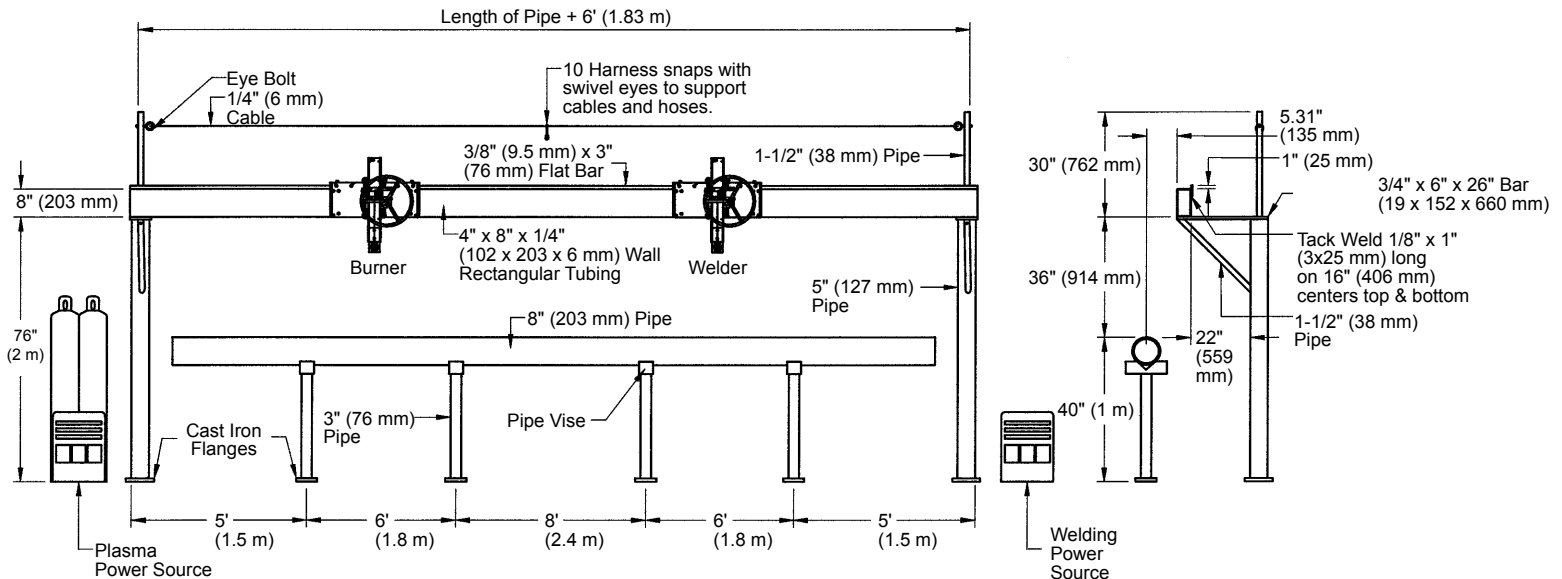

### Sequence of Operation

Position your pipe and move the CB-1P along the pipe to cut smooth, accurate holes. Position the CW-5 with a step adapter on the fitting and make the contour weld.

The approximate time for a cut is 6-10 seconds, depending upon diameter and thickness. The approximate time for a weld is 15-20 seconds.