

MAGNATECH

ORBITAL WELDING SYSTEMS

C-SERIES WELD HEADS

Models 819A, 821A,
822A, 823A

Orbital Weld Heads for Fusion
Welding of Tube and Pipe

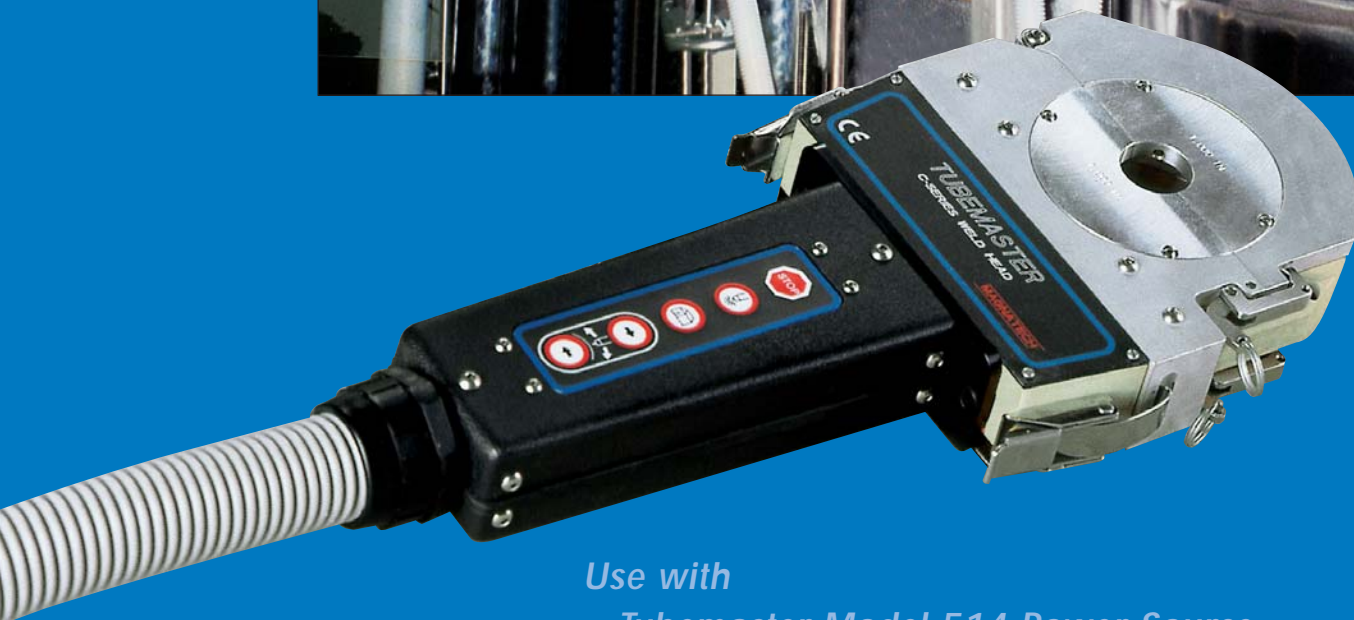
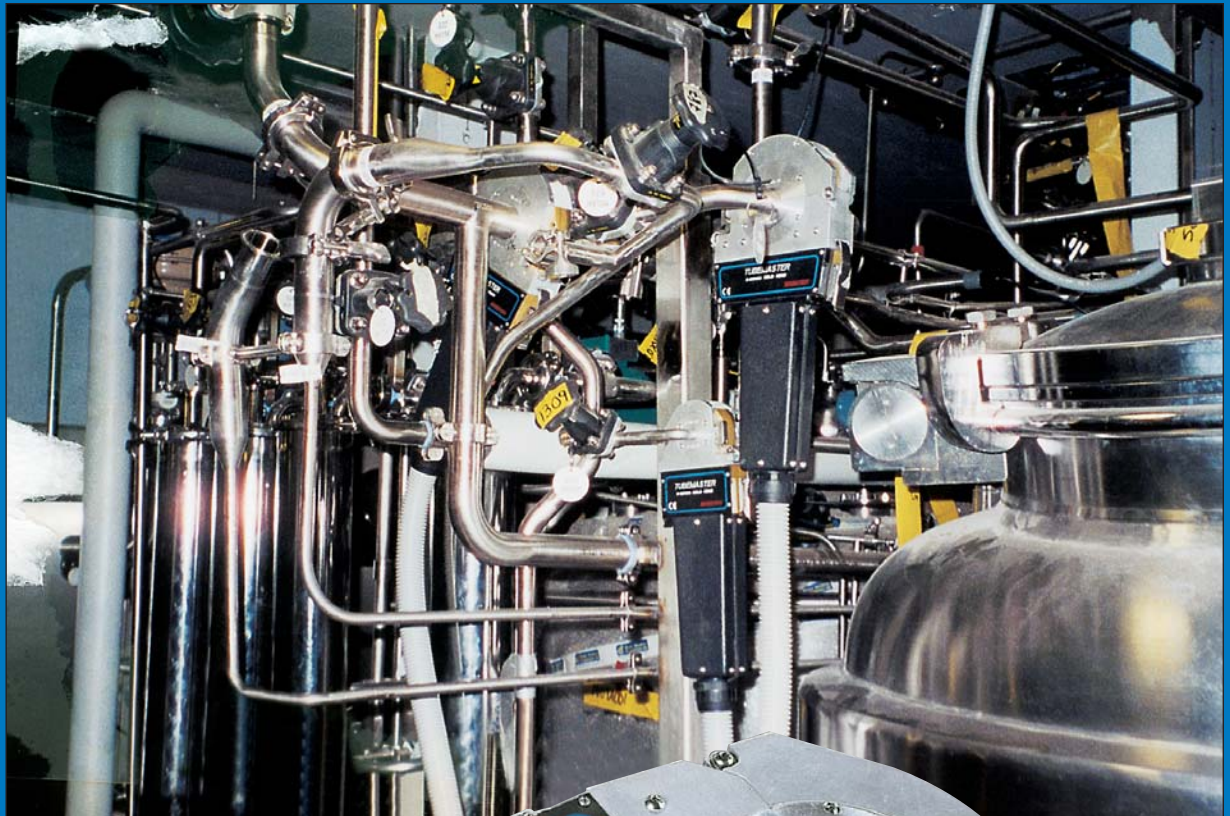

Use with

- Tubemaster Model 514 Power Source
- Pipemaster Model 515 Power Source

C-Series Weld Heads

Orbital Weld Heads for Fusion Welding of Tube and Pipe

Precision Tools for Precise, Repeatable Welds

The C-Series are easy-to-operate tools for autogenous tube welding. Four models cover tube size range from 6mm to 114mm (0.25"–4.5") O.D. Magnatech C-Series Heads make tube-to-tube and tube-to-fitting welds with precision and repeatability.

The double-clamping design simplifies work piece fit-up and eliminates tack welding in many cases. Collets are available for any tube and fitting size.

Digital technology forever eliminates the need for periodic weld Head calibration – rotation speed remains accurate regardless of Head wear, and Heads can be interchanged without time-consuming recalibration.



Applications

- Semiconductor/High Purity
- Pharmaceutical
- Sanitary (Hygienic) Process Pipe
- Aerospace
- Medical/Biotechnology
- Food Processing/Dairy
- Brewery
- Instrumentation



Features

- Collets for all tube size/fitting geometries
- Detachable cartridge simplifies fit-up and clamping
- Waterproof carry case standard
- Internal Weld Head cooling standard
- Glass view port allows final inspection before welding
- Unique insulated collets and cartridge prevent internal "arc over"
- Encoder motors provide precise, repeatable speed regulation
- Encoder motors provide "jam" protection. If rotation stops for any reason, it is instantly sensed and power to the motor is immediately interrupted. No more damaged motors or drive trains.



Glass View Port

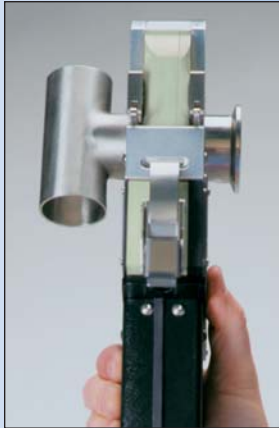

Narrow Profile



Simple Fit-Up and Clamping



Detachable Cartridges



All Operating Controls mounted on Head

Different Collet Types Available

- Flush collets for minimal axial clamping length
- Extended collets for maximum alignment capability
- Mixed set (one side flush, one side extended). Ideal for tube-to fitting welds. Flush clamping on fitting side, with extended clamping on tube side.
- Counterbored flush collets further reduce required axial clamping length (special)

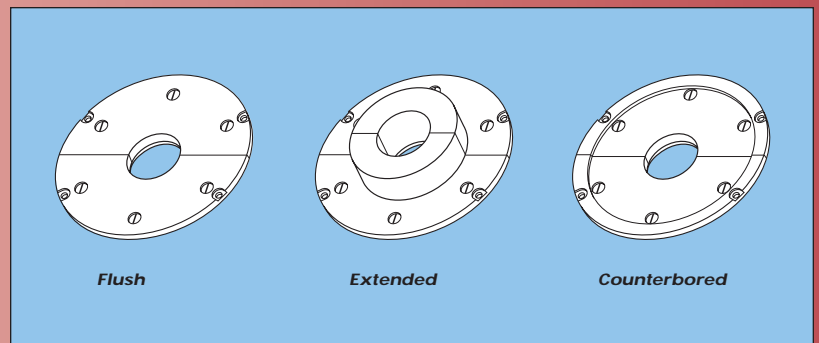

Flush

Extended

Counterbored

Options

- Extension cables allow use up to 23 meters (75 feet) from power supply
- Pre-ground tungsten electrodes
- Bench Mount Bracket firmly retains weld Head
- Offset Tungsten Holders (Butt weld) allow use when axial clearance restrictions exist (such as short tangent fittings)
- Offset Tungsten Holders (Fillet weld) allow fillet (socket) welds to be made
- Manual tack welding kit includes water-cooled torch with quick disconnect adaptor fittings

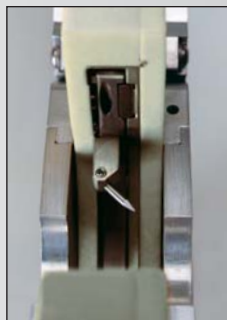

Offset Tungsten Holder for Fillet Weld



Collets removed to show Fillet Weld



Tungsten Electrodes



Bench Mount Bracket

Specifications

Application	Orbital Autogenous GTAW welding of tube-to-tube, tube-to-fitting, fitting-to-fitting
Cable Length	8 m (25') Standard. Extension cables available
Power Supply Compatibility	Tubemaster Models; Pipemaster Models
Tungsten Electrode Size	All C-Heads allow for mounting of two electrode sizes: C-10 Model 1.0mm and 1.6mm (.040" and .0625") C-25, C-35, C-45 Models 1.6mm and 2.4mm (.0625" and .094")

Dimensions/Weights

	C-10 (Model 819A)	C-25 (Model 821A)	C-35 (Model 822A)	C-45 (Model 823A)
Tube Diameter Range ¹	6–25mm (.25–1.0")	12–64mm (.5–2.5")	19–89mm (.75–3.5")	25–114mm (1.0–4.5")
RPM Range	0.6 – 9.5	0.3 – 5.0	0.1 – 2.5	0.1 – 2.3
Weight (excl. cable)	1.8 kg (4 lbs.)	2.7 kg (6 lbs.)	4.5 kg (10 lbs.)	6.4 kg (14 lbs.)
"A" Radius	39.1mm (1.54")	71.1mm (2.80")	89.9mm (3.54")	115.3mm (4.54")
"B" Length	305mm (12.0")	351mm (13.8")	391mm (15.4")	480mm (18.9")
"C" Width	103mm (4.34")	153mm (6.04")	186mm (7.29")	230mm (9.04")
"D" Thickness ²	45mm (1.77")	45mm (1.77")	45mm (1.77")	52.5mm (2.07")
"E" Tungsten Offset Clearance ³	20mm (.790")	20mm (.790")	20mm (.790")	26.3mm (1.035")
Optional Counterbored Collets	19mm (.750")	19mm (.750")	19mm (.750")	25.3mm (.995")

¹ Minimum tube size range can be extended – contact Factory

² Axial dimensions when clamped on tube with flush collets

³ Distance from nearest flush collet face to tungsten centerline. (Tungsten offset from center of weld Head)

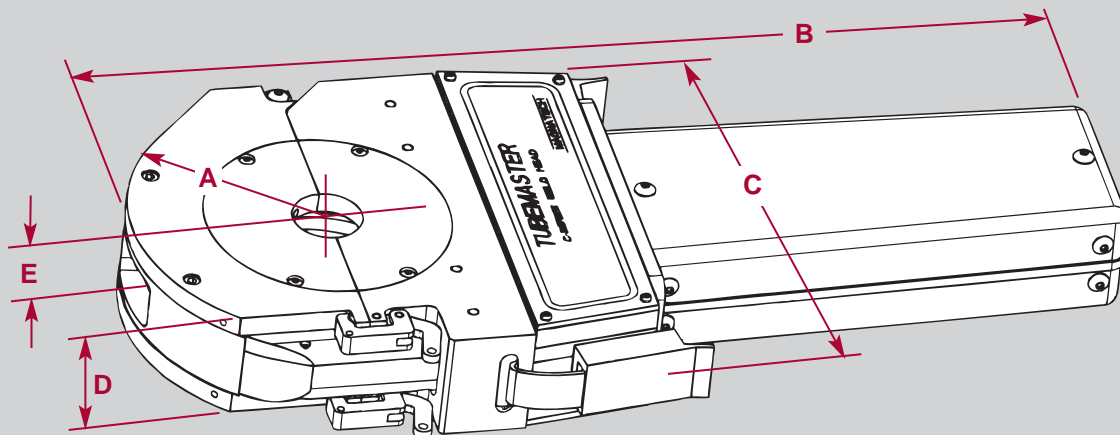

Represented By:

MAGNATECH

Headquarters: **MAGNATECH LIMITED PARTNERSHIP**
6 Kripes Road, P.O. Box 260, East Granby, CT 06026-0260
Telephone: (+1) 860 653-2573 • Fax: (+1) 860 653-0486
E-Mail: info@magnatech-ip.com
Web Site: www.magnatech-ip.com

European Office: **MAGNATECH EUROPE B.V.**
Ambachtshof 15, 8251 KV Dronten, The Netherlands
Telephone: (+31) 321 38 6677 • Fax: (+31) 321 31 4165
E-Mail: info@magnatech-europe.com
Web Site: www.magnatech-europe.com