

LN-15 WIRE FEEDER

For use with machines having Code Number: 11372



This manual covers equipment which is no longer in production by The Lincoln Electric Co. Specifications and availability of optional features may have changed.

Safety Depends on You

Lincoln arc welding and cutting equipment is designed and built with safety in mind. However, your overall safety can be increased by proper installation ... and thoughtful operation on your part. **DO NOT INSTALL, OPERATE OR REPAIR THIS EQUIPMENT WITHOUT READING THIS MANUAL AND THE SAFETY PRECAUTIONS CONTAINED THROUGHOUT.** And, most importantly, think before you act and be careful.



IEC 60974-5

EN 60974-5

OPERATOR'S MANUAL



Copyright © Lincoln Global Inc.

• World's Leader in Welding and Cutting Products •

• Sales and Service through Subsidiaries and Distributors Worldwide •

Cleveland, Ohio 44117-1199 U.S.A. TEL: 216.481.8100 FAX: 216.486.1751 WEB SITE: www.lincolnelectric.com

⚠ WARNING



CALIFORNIA PROPOSITION 65 WARNINGS



Diesel engine exhaust and some of its constituents are known to the State of California to cause cancer, birth defects, and other reproductive harm.

The Above For Diesel Engines

The engine exhaust from this product contains chemicals known to the State of California to cause cancer, birth defects, or other reproductive harm.

The Above For Gasoline Engines

ARC WELDING CAN BE HAZARDOUS. PROTECT YOURSELF AND OTHERS FROM POSSIBLE SERIOUS INJURY OR DEATH. KEEP CHILDREN AWAY. PACEMAKER WEARERS SHOULD CONSULT WITH THEIR DOCTOR BEFORE OPERATING.

Read and understand the following safety highlights. For additional safety information, it is strongly recommended that you purchase a copy of "Safety in Welding & Cutting - ANSI Standard Z49.1" from the American Welding Society, P.O. Box 351040, Miami, Florida 33135 or CSA Standard W117.2-1974. A Free copy of "Arc Welding Safety" booklet E205 is available from the Lincoln Electric Company, 22801 St. Clair Avenue, Cleveland, Ohio 44117-1199.

BE SURE THAT ALL INSTALLATION, OPERATION, MAINTENANCE AND REPAIR PROCEDURES ARE PERFORMED ONLY BY QUALIFIED INDIVIDUALS.



FOR ENGINE powered equipment.

1.a. Turn the engine off before troubleshooting and maintenance work unless the maintenance work requires it to be running.



1.b. Operate engines in open, well-ventilated areas or vent the engine exhaust fumes outdoors.



1.c. Do not add the fuel near an open flame welding arc or when the engine is running. Stop the engine and allow it to cool before refueling to prevent spilled fuel from vaporizing on contact with hot engine parts and igniting. Do not spill fuel when filling tank. If fuel is spilled, wipe it up and do not start engine until fumes have been eliminated.

1.d. Keep all equipment safety guards, covers and devices in position and in good repair. Keep hands, hair, clothing and tools away from V-belts, gears, fans and all other moving parts when starting, operating or repairing equipment.

1.e. In some cases it may be necessary to remove safety guards to perform required maintenance. Remove guards only when necessary and replace them when the maintenance requiring their removal is complete. Always use the greatest care when working near moving parts.



1.f. Do not put your hands near the engine fan. Do not attempt to override the governor or idler by pushing on the throttle control rods while the engine is running.

1.g. To prevent accidentally starting gasoline engines while turning the engine or welding generator during maintenance work, disconnect the spark plug wires, distributor cap or magneto wire as appropriate.



1.h. To avoid scalding, do not remove the radiator pressure cap when the engine is hot.



ELECTRIC AND MAGNETIC FIELDS may be dangerous

2.a. Electric current flowing through any conductor causes localized Electric and Magnetic Fields (EMF). Welding current creates EMF fields around welding cables and welding machines

2.b. EMF fields may interfere with some pacemakers, and welders having a pacemaker should consult their physician before welding.

2.c. Exposure to EMF fields in welding may have other health effects which are now not known.

2.d. All welders should use the following procedures in order to minimize exposure to EMF fields from the welding circuit:

2.d.1. Route the electrode and work cables together - Secure them with tape when possible.

2.d.2. Never coil the electrode lead around your body.

2.d.3. Do not place your body between the electrode and work cables. If the electrode cable is on your right side, the work cable should also be on your right side.

2.d.4. Connect the work cable to the workpiece as close as possible to the area being welded.

2.d.5. Do not work next to welding power source.

Mar '95



ELECTRIC SHOCK can kill.

- 3.a. The electrode and work (or ground) circuits are electrically "hot" when the welder is on. Do not touch these "hot" parts with your bare skin or wet clothing. Wear dry, hole-free gloves to insulate hands.
- 3.b. Insulate yourself from work and ground using dry insulation. Make certain the insulation is large enough to cover your full area of physical contact with work and ground.

In addition to the normal safety precautions, if welding must be performed under electrically hazardous conditions (in damp locations or while wearing wet clothing; on metal structures such as floors, gratings or scaffolds; when in cramped positions such as sitting, kneeling or lying, if there is a high risk of unavoidable or accidental contact with the workpiece or ground) use the following equipment:

- **Semiautomatic DC Constant Voltage (Wire) Welder.**
 - **DC Manual (Stick) Welder.**
 - **AC Welder with Reduced Voltage Control.**
- 3.c. In semiautomatic or automatic wire welding, the electrode, electrode reel, welding head, nozzle or semiautomatic welding gun are also electrically "hot".
- 3.d. Always be sure the work cable makes a good electrical connection with the metal being welded. The connection should be as close as possible to the area being welded.
- 3.e. Ground the work or metal to be welded to a good electrical (earth) ground.
- 3.f. Maintain the electrode holder, work clamp, welding cable and welding machine in good, safe operating condition. Replace damaged insulation.
- 3.g. Never dip the electrode in water for cooling.
- 3.h. Never simultaneously touch electrically "hot" parts of electrode holders connected to two welders because voltage between the two can be the total of the open circuit voltage of both welders.
- 3.i. When working above floor level, use a safety belt to protect yourself from a fall should you get a shock.
- 3.j. Also see Items 6.c. and 8.



ARC RAYS can burn.

- 4.a. Use a shield with the proper filter and cover plates to protect your eyes from sparks and the rays of the arc when welding or observing open arc welding. Headshield and filter lens should conform to ANSI Z87.1 standards.
- 4.b. Use suitable clothing made from durable flame-resistant material to protect your skin and that of your helpers from the arc rays.
- 4.c. Protect other nearby personnel with suitable, non-flammable screening and/or warn them not to watch the arc nor expose themselves to the arc rays or to hot spatter or metal.



FUMES AND GASES can be dangerous.

- 5.a. Welding may produce fumes and gases hazardous to health. Avoid breathing these fumes and gases. When welding, keep your head out of the fume. Use enough ventilation and/or exhaust at the arc to keep fumes and gases away from the breathing zone. **When welding with electrodes which require special ventilation such as stainless or hard facing (see instructions on container or MSDS) or on lead or cadmium plated steel and other metals or coatings which produce highly toxic fumes, keep exposure as low as possible and within applicable OSHA PEL and ACGIH TLV limits using local exhaust or mechanical ventilation. In confined spaces or in some circumstances, outdoors, a respirator may be required. Additional precautions are also required when welding on galvanized steel.**
5. b. The operation of welding fume control equipment is affected by various factors including proper use and positioning of the equipment, maintenance of the equipment and the specific welding procedure and application involved. Worker exposure level should be checked upon installation and periodically thereafter to be certain it is within applicable OSHA PEL and ACGIH TLV limits.
- 5.c. Do not weld in locations near chlorinated hydrocarbon vapors coming from degreasing, cleaning or spraying operations. The heat and rays of the arc can react with solvent vapors to form phosgene, a highly toxic gas, and other irritating products.
- 5.d. Shielding gases used for arc welding can displace air and cause injury or death. Always use enough ventilation, especially in confined areas, to insure breathing air is safe.
- 5.e. Read and understand the manufacturer's instructions for this equipment and the consumables to be used, including the material safety data sheet (MSDS) and follow your employer's safety practices. MSDS forms are available from your welding distributor or from the manufacturer.
- 5.f. Also see item 1.b.

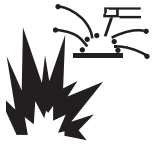

WELDING and CUTTING SPARKS can cause fire or explosion.

- 6.a. Remove fire hazards from the welding area. If this is not possible, cover them to prevent the welding sparks from starting a fire. Remember that welding sparks and hot materials from welding can easily go through small cracks and openings to adjacent areas. Avoid welding near hydraulic lines. Have a fire extinguisher readily available.
- 6.b. Where compressed gases are to be used at the job site, special precautions should be used to prevent hazardous situations. Refer to "Safety in Welding and Cutting" (ANSI Standard Z49.1) and the operating information for the equipment being used.
- 6.c. When not welding, make certain no part of the electrode circuit is touching the work or ground. Accidental contact can cause overheating and create a fire hazard.
- 6.d. Do not heat, cut or weld tanks, drums or containers until the proper steps have been taken to insure that such procedures will not cause flammable or toxic vapors from substances inside. They can cause an explosion even though they have been "cleaned". For information, purchase "Recommended Safe Practices for the Preparation for Welding and Cutting of Containers and Piping That Have Held Hazardous Substances", AWS F4.1 from the American Welding Society (see address above).
- 6.e. Vent hollow castings or containers before heating, cutting or welding. They may explode.
- 6.f. Sparks and spatter are thrown from the welding arc. Wear oil free protective garments such as leather gloves, heavy shirt, cuffless trousers, high shoes and a cap over your hair. Wear ear plugs when welding out of position or in confined places. Always wear safety glasses with side shields when in a welding area.
- 6.g. Connect the work cable to the work as close to the welding area as practical. Work cables connected to the building framework or other locations away from the welding area increase the possibility of the welding current passing through lifting chains, crane cables or other alternate circuits. This can create fire hazards or overheat lifting chains or cables until they fail.
- 6.h. Also see item 1.c.
- 6.i. Read and follow NFPA 51B "Standard for Fire Prevention During Welding, Cutting and Other Hot Work", available from NFPA, 1 Batterymarch Park, PO box 9101, Quincy, Ma 022690-9101.
- 6.j. Do not use a welding power source for pipe thawing.



CYLINDER may explode if damaged.

- 7.a. Use only compressed gas cylinders containing the correct shielding gas for the process used and properly operating regulators designed for the gas and pressure used. All hoses, fittings, etc. should be suitable for the application and maintained in good condition.
- 7.b. Always keep cylinders in an upright position securely chained to an undercarriage or fixed support.
- 7.c. Cylinders should be located:
 - Away from areas where they may be struck or subjected to physical damage.
 - A safe distance from arc welding or cutting operations and any other source of heat, sparks, or flame.
- 7.d. Never allow the electrode, electrode holder or any other electrically "hot" parts to touch a cylinder.
- 7.e. Keep your head and face away from the cylinder valve outlet when opening the cylinder valve.
- 7.f. Valve protection caps should always be in place and hand tight except when the cylinder is in use or connected for use.
- 7.g. Read and follow the instructions on compressed gas cylinders, associated equipment, and CGA publication P-1, "Precautions for Safe Handling of Compressed Gases in Cylinders," available from the Compressed Gas Association 1235 Jefferson Davis Highway, Arlington, VA 22202.



FOR ELECTRICALLY powered equipment.

- 8.a. Turn off input power using the disconnect switch at the fuse box before working on the equipment.
- 8.b. Install equipment in accordance with the U.S. National Electrical Code, all local codes and the manufacturer's recommendations.
- 8.c. Ground the equipment in accordance with the U.S. National Electrical Code and the manufacturer's recommendations.

Refer to <http://www.lincolnelectric.com/safety> for additional safety information.

PRÉCAUTIONS DE SÛRETÉ

Pour votre propre protection lire et observer toutes les instructions et les précautions de sûreté spécifiques qui paraissent dans ce manuel aussi bien que les précautions de sûreté générales suivantes:

Sûreté Pour Soudage A L'Arc

1. Protégez-vous contre la secousse électrique:
 - a. Les circuits à l'électrode et à la pièce sont sous tension quand la machine à souder est en marche. Éviter toujours tout contact entre les parties sous tension et la peau nue ou les vêtements mouillés. Porter des gants secs et sans trous pour isoler les mains.
 - b. Faire très attention de bien s'isoler de la masse quand on soude dans des endroits humides, ou sur un plancher métallique ou des grilles métalliques, principalement dans les positions assis ou couché pour lesquelles une grande partie du corps peut être en contact avec la masse.
 - c. Maintenir le porte-électrode, la pince de masse, le câble de soudage et la machine à souder en bon et sûr état de fonctionnement.
 - d. Ne jamais plonger le porte-électrode dans l'eau pour le refroidir.
 - e. Ne jamais toucher simultanément les parties sous tension des porte-électrodes connectés à deux machines à souder parce que la tension entre les deux pinces peut être le total de la tension à vide des deux machines.
 - f. Si on utilise la machine à souder comme une source de courant pour soudage semi-automatique, ces précautions pour le porte-électrode s'appliquent aussi au pistolet de soudage.
2. Dans le cas de travail au dessus du niveau du sol, se protéger contre les chutes dans le cas où on reçoit un choc. Ne jamais enrouler le câble-électrode autour de n'importe quelle partie du corps.
3. Un coup d'arc peut être plus sévère qu'un coup de soleil, donc:
 - a. Utiliser un bon masque avec un verre filtrant approprié ainsi qu'un verre blanc afin de se protéger les yeux du rayonnement de l'arc et des projections quand on soude ou quand on regarde l'arc.
 - b. Porter des vêtements convenables afin de protéger la peau de soudeur et des aides contre le rayonnement de l'arc.
 - c. Protéger l'autre personnel travaillant à proximité au soudage à l'aide d'écrans appropriés et non-inflammables.
4. Des gouttes de laitier en fusion sont émises de l'arc de soudage. Se protéger avec des vêtements de protection libres de l'huile, tels que les gants en cuir, chemise épaisse, pantalons sans revers, et chaussures montantes.
5. Toujours porter des lunettes de sécurité dans la zone de soudage. Utiliser des lunettes avec écrans latéraux dans les zones où l'on pique le laitier.

6. Eloigner les matériaux inflammables ou les recouvrir afin de prévenir tout risque d'incendie dû aux étincelles.
7. Quand on ne soude pas, poser la pince à un endroit isolé de la masse. Un court-circuit accidentel peut provoquer un échauffement et un risque d'incendie.
8. S'assurer que la masse est connectée le plus près possible de la zone de travail qu'il est pratique de le faire. Si on place la masse sur la charpente de la construction ou d'autres endroits éloignés de la zone de travail, on augmente le risque de voir passer le courant de soudage par les chaînes de levage, câbles de grue, ou autres circuits. Cela peut provoquer des risques d'incendie ou d'échauffement des chaînes et des câbles jusqu'à ce qu'ils se rompent.
9. Assurer une ventilation suffisante dans la zone de soudage. Ceci est particulièrement important pour le soudage de tôles galvanisées plombées, ou cadmiées ou tout autre métal qui produit des fumées toxiques.
10. Ne pas souder en présence de vapeurs de chlore provenant d'opérations de dégraissage, nettoyage ou pistolage. La chaleur ou les rayons de l'arc peuvent réagir avec les vapeurs du solvant pour produire du phosgène (gas fortement toxique) ou autres produits irritants.
11. Pour obtenir de plus amples renseignements sur la sûreté, voir le code "Code for safety in welding and cutting" CSA Standard W 117.2-1974.

PRÉCAUTIONS DE SÛRETÉ POUR LES MACHINES À SOUDER À TRANSFORMATEUR ET À REDRESSEUR

1. Relier à la terre le châssis du poste conformément au code de l'électricité et aux recommandations du fabricant. Le dispositif de montage ou la pièce à souder doit être branché à une bonne mise à la terre.
2. Autant que possible, l'installation et l'entretien du poste seront effectués par un électricien qualifié.
3. Avant de faire des travaux à l'intérieur de poste, le débrancher à l'interrupteur à la boîte de fusibles.
4. Garder tous les couvercles et dispositifs de sûreté à leur place.

Mar. '93

ELECTROMAGNETIC COMPATIBILITY (EMC)

Conformance

Products displaying the CE mark are in conformity with European Community Council Directive of 3 May 1989 on the approximation of the laws of the Member States relating to electromagnetic compatibility (89/336/EEC). It was manufactured in conformity with a national standard that implements a harmonized standard: EN **60974-10** Electromagnetic Compatibility (EMC) Product Standard for Arc Welding Equipment. It is for use with other Lincoln Electric equipment. It is designed for industrial and professional use.

Introduction

All electrical equipment generates small amounts of electromagnetic emission. Electrical emission may be transmitted through power lines or radiated through space, similar to a radio transmitter. When emissions are received by other equipment, electrical interference may result. Electrical emissions may affect many kinds of electrical equipment; other nearby welding equipment, radio and TV reception, numerical controlled machines, telephone systems, computers, etc. Be aware that interference may result and extra precautions may be required when a welding power source is used in a domestic establishment.

Installation and Use

The user is responsible for installing and using the welding equipment according to the manufacturer's instructions. If electromagnetic disturbances are detected then it shall be the responsibility of the user of the welding equipment to resolve the situation with the technical assistance of the manufacturer. In some cases this remedial action may be as simple as earthing (grounding) the welding circuit, see Note. In other cases it could involve constructing an electromagnetic screen enclosing the power source and the work complete with associated input filters. In all cases electromagnetic disturbances must be reduced to the point where they are no longer troublesome.

Note: The welding circuit may or may not be earthed for safety reasons according to national codes. Changing the earthing arrangements should only be authorized by a person who is competent to assess whether the changes will increase the risk of injury, e.g., by allowing parallel welding current return paths which may damage the earth circuits of other equipment.

Assessment of Area

Before installing welding equipment the user shall make an assessment of potential electromagnetic problems in the surrounding area. The following shall be taken into account:

- a) other supply cables, control cables, signaling and telephone cables; above, below and adjacent to the welding equipment;
- b) radio and television transmitters and receivers;
- c) computer and other control equipment;
- d) safety critical equipment, e.g., guarding of industrial equipment;
- e) the health of the people around, e.g., the use of pacemakers and hearing aids;
- f) equipment used for calibration or measurement;
- g) the immunity of other equipment in the environment. The user shall ensure that other equipment being used in the environment is compatible. This may require additional protection measures;
- h) the time of day that welding or other activities are to be carried out.

3-1-96H

L10093

ELECTROMAGNETIC COMPATIBILITY (EMC)

The size of the surrounding area to be considered will depend on the structure of the building and other activities that are taking place. The surrounding area may extend beyond the boundaries of the premises.

Methods of Reducing Emissions

Mains Supply

Welding equipment should be connected to the mains supply according to the manufacturer's recommendations. If interference occurs, it may be necessary to take additional precautions such as filtering of the mains supply. Consideration should be given to shielding the supply cable of permanently installed welding equipment, in metallic conduit or equivalent. Shielding should be electrically continuous throughout its length. The shielding should be connected to the welding power source so that good electrical contact is maintained between the conduit and the welding power source enclosure.

Maintenance of the Welding Equipment

The welding equipment should be routinely maintained according to the manufacturer's recommendations. All access and service doors and covers should be closed and properly fastened when the welding equipment is in operation. The welding equipment should not be modified in any way except for those changes and adjustments covered in the manufacturer's instructions. In particular, the spark gaps of arc striking and stabilizing devices should be adjusted and maintained according to the manufacturer's recommendations.

Welding Cables

The welding cables should be kept as short as possible and should be positioned close together, running at or close to the floor level.

Equipotential Bonding

Bonding of all metallic components in the welding installation and adjacent to it should be considered. However, metallic components bonded to the work piece will increase the risk that the operator could receive a shock by touching these metallic components and the electrode at the same time. The operator should be insulated from all such bonded metallic components.

Earthing of the Workpiece

Where the workpiece is not bonded to earth for electrical safety, not connected to earth because of its size and position, e.g., ships hull or building steelwork, a connection bonding the workpiece to earth may reduce emissions in some, but not all instances. Care should be taken to prevent the earthing of the workpiece increasing the risk of injury to users, or damage to other electrical equipment. Where necessary, the connection of the workpiece to earth should be made by a direct connection to the workpiece, but in some countries where direct connection is not permitted, the bonding should be achieved by suitable capacitance, selected according to national regulations.

Screening and Shielding

Selective screening and shielding of other cables and equipment in the surrounding area may alleviate problems of interference. Screening of the entire welding installation may be considered for special applications.¹

¹ Portions of the preceding text are contained in **EN 60974-10**: "Electromagnetic Compatibility (EMC) product standard for arc welding equipment."

Thank You

for selecting a **QUALITY** product by Lincoln Electric. We want you to take pride in operating this Lincoln Electric Company product
 ... as much pride as we have in bringing this product to you!

CUSTOMER ASSISTANCE POLICY

The business of The Lincoln Electric Company is manufacturing and selling high quality welding equipment, consumables, and cutting equipment. Our challenge is to meet the needs of our customers and to exceed their expectations. On occasion, purchasers may ask Lincoln Electric for advice or information about their use of our products. We respond to our customers based on the best information in our possession at that time. Lincoln Electric is not in a position to warrant or guarantee such advice, and assumes no liability, with respect to such information or advice. We expressly disclaim any warranty of any kind, including any warranty of fitness for any customer's particular purpose, with respect to such information or advice. As a matter of practical consideration, we also cannot assume any responsibility for updating or correcting any such information or advice once it has been given, nor does the provision of information or advice create, expand or alter any warranty with respect to the sale of our products.

Lincoln Electric is a responsive manufacturer, but the selection and use of specific products sold by Lincoln Electric is solely within the control of, and remains the sole responsibility of the customer. Many variables beyond the control of Lincoln Electric affect the results obtained in applying these types of fabrication methods and service requirements.

Subject to Change – This information is accurate to the best of our knowledge at the time of printing. Please refer to www.lincolnelectric.com for any updated information.

Please Examine Carton and Equipment For Damage Immediately

When this equipment is shipped, title passes to the purchaser upon receipt by the carrier. Consequently, Claims for material damaged in shipment must be made by the purchaser against the transportation company at the time the shipment is received.

Please record your equipment identification information below for future reference. This information can be found on your machine nameplate.

Product _____

Model Number _____

Code Number or Date Code _____

Serial Number _____

Date Purchased _____

Where Purchased _____

Whenever you request replacement parts or information on this equipment, always supply the information you have recorded above. The code number is especially important when identifying the correct replacement parts.

On-Line Product Registration

- Register your machine with Lincoln Electric either via fax or over the Internet.
 - For faxing: Complete the form on the back of the warranty statement included in the literature packet accompanying this machine and fax the form per the instructions printed on it.
 - For On-Line Registration: Go to our **WEB SITE at www.lincolnelectric.com**. Choose "Quick Links" and then "Product Registration". Please complete the form and submit your registration.

Read this Operators Manual completely before attempting to use this equipment. Save this manual and keep it handy for quick reference. Pay particular attention to the safety instructions we have provided for your protection. The level of seriousness to be applied to each is explained below:

⚠ WARNING

This statement appears where the information **must** be followed **exactly** to avoid **serious personal injury** or **loss of life**.

⚠ CAUTION

This statement appears where the information **must** be followed to avoid **minor personal injury** or **damage to this equipment**.

	Page
Installation.....	Section A
Technical Specifications.....	A-1
Safety Precautions.....	A-2
Location.....	A-2
High Frequency Protection.....	A-2
Weld Cable Connections.....	A-2
Electrode Connection.....	A-3
Work Connection.....	A-3
Power Source Connection.....	A-3
Engine Drive Power Source Connection.....	A-3
Connection Diagram.....	A-3
Guns and Cables.....	A-4
Electrode Polarity.....	A-4
Control Cable Connections.....	A-4
Procedure to Install Drive Rolls and Wire Guides.....	A-5
Feeding Wire Electrode.....	A-5
Operation.....	Section B
Safety Precautions.....	B-1
Graphic Symbols that appear on this Machine or in this Manual.....	B-1
General Description.....	B-2
Duty Cycle.....	B-2
Recommended Processes.....	B-2
Process Limitations.....	B-2
Equipment Limitations.....	B-2
Operational Features and Controls.....	B-2
Case Front Controls.....	B-3
83% Procedure.....	B-3
LN-15 POWER UP SEQUENCE.....	B-4,B-5
Internal Controls.....	B-5
Spring Tension Arm.....	B-5
Wire Drive Configuration.....	B-6
Cold Feed/Gas Purge Switch.....	B-6
2 Step-Trigger Interlock Switch.....	B-7
Flow Meter.....	B-7
Spindle Brake.....	B-7
Shielding Gas Connection.....	B-7
Constant Current Operation.....	B-8
Setting Arc Sensing wire Feed Speed For Constant Current Operation.....	B-9
Making a Weld.....	B-10
Accessories.....	Section C
Factory Installed Equipment.....	C-1
Optional Equipment.....	C-1
Electrode, K-Kit used.....	C-1
Maintenance.....	Section D
Safety Precautions.....	D-1
Routine Maintenance.....	D-1
Periodic Maintenance.....	D-1
Calibration Specification.....	D-1
Troubleshooting.....	Section E
Safety Precautions.....	E-1
How to Use Troubleshooting Guide.....	E-1
Troubleshooting Guide.....	E-2 thru E-4
Wiring Diagram & Dimension Prints.....	Section F
Parts Pages.....	P-544

TECHNICAL SPECIFICATIONS – LN-15 (K1871-3 CE)

INPUT VOLTAGE				
42 VAC/1/50/60 (5 Amps Maximum) CONTROL CABLE MODEL				
RATED CURRENT				
500 Amps 60% Duty Cycle				
350 Amps 100% Duty Cycle				
ELECTRODE DIAMETERS and SPEED RANGE				
		Electrode Size	Speed Range	
	Solid Electrode Steel	0.023 - 0.052" (0.6 - 1.3 mm)	50 - 700 in/min (1.3 - 17.8 m/min)	
	Flux Cored Electrode	0.035 - 5/64" (0.9 - 2.3 mm)	50 - 400 in/min (1.3 - 10.1 m/min)	
PHYSICAL DIMENSIONS				
HEIGHT	WIDTH	DEPTH	WEIGHT	SPOOL SIZE CAPABILITY
12.7 Inches (323 mm)	8.7 Inches (221mm)	23 Inches (584 mm)	28lbs (13kg)	8 (200mm) Dia. x 4 (100mm) Wide Spools including AWS 8 DIA. (10-15lbs) JIS S-3 200mm max. (5 - 7 kg) DIN 200 (5 kg)
TEMPERATURE RANGE				
OPERATION:	- 20° C to +50° C (- 4° F to +122° F)			
STORAGE:	- 40° C to +70° C (- 40° F to +158° F)			

LN-15 CONTROL CABLE MODEL (CE)



SAFETY PRECAUTIONS

⚠ WARNING

ELECTRIC SHOCK CAN KILL.



- ONLY QUALIFIED PERSONNEL SHOULD PERFORM THIS INSTALLATION.
- Turn off input power to the power source at the disconnect switch or fuse box before working on this equipment. Turn off the input power to any other equipment connected to the welding system at the disconnect switch or fuse box before working on the equipment.

Turn off the input power to any other equipment connected to the welding system at the disconnect switch or fuse box before working on the equipment.

- Do not touch electrically hot parts.
- Do not touch metal portions of the LN-15 work lead clip when the welding power source is on.
- Do not connect the LN-15 to a non-Lincoln TIG power source, a SQUARE WAVE TIG power source, or a PLASMA CUTTING power source.

LOCATION

The LN-15 should be positioned upright on a horizontal surface. Do not submerge the LN-15 in water. The best practice is to keep the wire feeder in a dry environment. When working outdoors in severe wet weather, place the LN-15 with the door facing up.

HIGH FREQUENCY PROTECTION

⚠ WARNING



To prevent possible damage to the LN-15, do not connect the LN-15 to non-Lincoln TIG or SQUARE WAVE power sources. TIG high frequency should never be applied to the LN-15.

Locate the LN-15 away from radio controlled machinery. The normal operation of the LN-15 may adversely affect the operation of RF controlled equipment, which may result in bodily injury or damage to the equipment total.

WELD CABLE CONNECTIONS

⚠ WARNING

ELECTRIC SHOCK CAN KILL.



- Only a qualified electrician should connect the electrode leads to the LN-15. Connections should be made in accordance with all local and national electrical codes. Failure to do so may result in bodily injury or death.

The size of the electrode cable and work cable must be sufficient for the maximum weld current and total cable length used. To avoid interference problems with other equipment and to achieve the best possible operation, route all cables directly to the work or wire feeder. Avoid excessive lengths and do not coil excess cable. Be sure the connection to the work makes tight metal-to-metal electrical contact. (See Table A.1)

TABLE A.1

Weld Current 60% Duty Cycle	Total Cable Length (electrode cable + work cable)			
	50 - 100' (15-30 m)	100 - 150' (30 - 46m)	150 - 200' (46 - 61m)	200 - 250' (61m - 76m)
200 Amps	2 AWG	2 AWG	1 AWG	1/0
300 Amps	1 AWG	1 AWG	1/0	2/0
400 Amps	2/0	2/0	3/0	3/0

ELECTRODE CONNECTION

Route the electrode cable through the strain relief in the rear of the case. Connect the electrode cable to the LN-15 connection block using the mounting hardware provided. Secure the cable by tightening the strain relief.

All domestic models are supplied with an optional pig-tail for customers that prefer to make a taped and bolted connection externally. **CE** models have a male twist connector for the electrode connection.

WORK CONNECTION

Connect a work lead of sufficient size between the proper output stud on the power source and the work. Be sure the connection to the work makes tight metal to metal electrical contact. Poor work lead connections can result in poor welding performance.

POWER SOURCE CONNECTION

The LN-15 can be used with any DC welding power source. A constant voltage power source is recommended; however, the LN-15 can also be used with a constant current power source as long as the open circuit voltage is less than 110VDC.

CAUTION

To prevent possible damage to the LN-15, do not connect the LN-15 to non-Lincoln TIG or square wave power sources. TIG high frequency should never be applied to the LN-15.

ENGINE DRIVE POWER SOURCE CONNECTION

The LN-15 sends a control signal to the engine drive and the electrode is not energized until the gun trigger is closed. When the gun trigger is closed the wire will begin to feed and the welding process is started.

1. Shut the welder off.
2. For electrode Positive polarity welding, connect the electrode cable to the "+" terminal of the welder and work cable to the "-" terminal of the welder. For Electrode Negative welding, connect the electrode cable to the "-" terminal of the welder and work cable to the "+" terminal of the welder.
3. Set the MODE switch on the engine drive to CV-WIRE.

4. Set the WELD TERMINALS switch to WELD TERMINALS OFF.
5. Set the WIRE FEEDER VOLTMETER switch to either "+" or "-" as required by the electrode polarity being used.
6. Set the ARC CONTROL knob to "0" initially and adjust to suit.
7. Set the IDLE switch to the AUTO position. Important: Some older engine drives may the IDLE switch to be in the HIGH position for proper LN-15 operation.

CONNECTION DIAGRAM, CONTROL CABLE MODELS (See Figure A.1)

FIGURE A.1

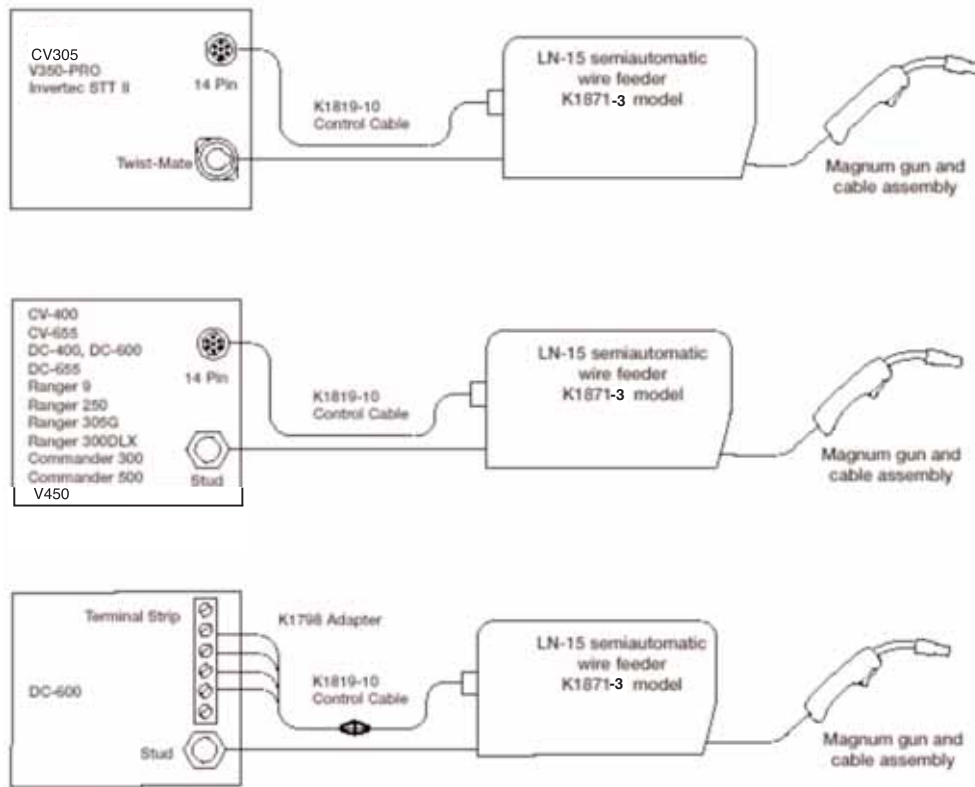

GUNS AND CABLES ASSEMBLIES

A variety of Lincoln 10' (3.0m) or 15' (4.6m) gun and cable assemblies are available for use with the LN-15, including the Magnum™ models for GMAW, K126 or K115 models for Innershield®, and more.

The LN-15 comes factory equipped with a K1500-2 gun connection kit, designed for guns having a Magnum Tweco™ compatible #2-#4 connector. Many other guns can easily be used with the LN-15 with other K1500 series gun connection kits.

Gun Cable Connection to the Feeder

Lay the cable out straight. Insert the connector on the welding conductor cable into the brass bushing on the front of the wire drive unit. Keep the all mating surfaces clean. Make sure it is fully seated and tighten the thumb screw.

Connect the control cable plug into the 5 pin receptacle on the front panel of the wire feeder.

ELECTRODE POLARITY

The LN-15 automatically adjusts for positive and negative polarity. When welding with negative polarity procedures, the voltmeter will display a "-" sign; example "-23.6" Volts.

CONTROL CABLE CONNECTIONS

For Control Cable model, attach the control cable from the LN-15 to power source. Do not use more than 150 ft (45 m) of cable.

Table A.2 Trigger Connector J1 (5 Pin)

PIN	Lead #	Function
A	556	Trigger
B	-	Not used
C	554	Trigger/ 83% Procedure ground
D	555	83% Procedure
E	554	Trigger/ 83% Procedure ground

Table A.3 Control Cable Receptacle (8 Pin)

PIN	Lead #	Function
A	41	42 VAC
B	42	42 VAC
C	2	Output Control (trigger)
D	4	Output Control (trigger)
E	21	Work Sense Lead
F	75	Remote Voltage Control
G	76	Remote Voltage Control
H	77	Remote Voltage Control

LN-15 CONTROL CABLE MODEL (CE)



PROCEDURE TO INSTALL DRIVE ROLLS AND WIRE GUIDES

WARNING

ELECTRIC SHOCK CAN KILL.



- Turn off input power at the welding power source before installation or changing drive roll and/or wire guides.

- Do not touch electrically live parts such as the wire drive or internal wiring.
- When feeding with the gun trigger, the electrode and wire drive mechanism are "hot" to work and ground and could remain energized several seconds after the gun trigger is released.
- Only qualified personnel should perform this operation.

1. Turn OFF the welding power source.
2. Open the LN-15 case and then release the idle roll pressure arm.
3. Remove the outer wire guide by turning the knurled thumbscrews counter-clockwise to unscrew them from the feed plate.
4. Rotate the triangular shaped drive roll retaining mechanism to unlock the drive rolls and remove the drive rolls.

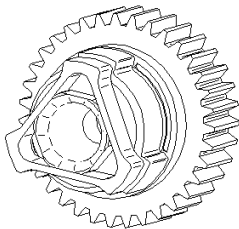

**UNLOCKED
POSITION**

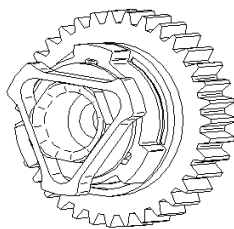

**LOCKED
POSITION**

5. Remove the inner wire guide.
6. Insert the new inner wire guide, groove side out, over the two locating pins in the feed plate.
7. Install a drive roll on each hub assembly and lock by rotating the triangular drive roll retaining mechanism.
8. Install the outer wire guide by aligning it with the pins and tightening the knurled thumbscrews.
9. Close the idle arm and engage the idle roll pressure arm. Adjust the pressure appropriately.

FEEDING WIRE ELECTRODE

WARNING

ELECTRIC SHOCK CAN KILL.



- When feeding electrode with the gun trigger, the electrode and wire drive mechanism are always "hot" to work and ground and could remain "hot" several seconds after the gun trigger is released.

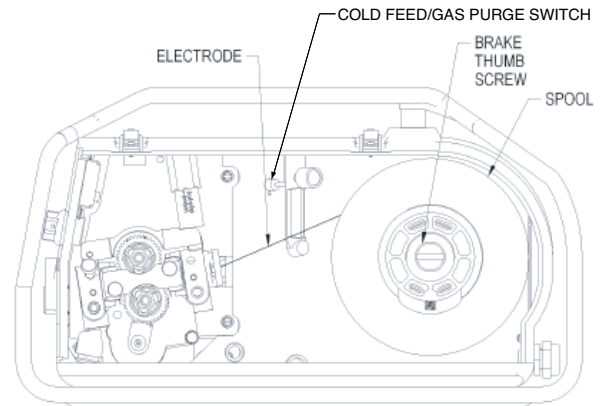

1. Turn the reel or spool until the free end of the electrode is accessible.
2. While tightly holding the electrode, cut off the bent end and straighten the first 6" (15 cm). Cut off the first 1" (2.5 cm). If the electrode is not properly straightened, it may not feed or may jam.
3. Insert the free end through the incoming guide bushing.
4. Press the Cold Feed switch and push the electrode into the drive roll.
5. Feed the electrode through the gun.
6. Adjust the brake tension with the thumbscrew on the spindle hub, until the reel turns freely but with little or no overrun when the wire feeding stops. Do not overtighten.

LN-15 CONTROL CABLE MODEL (CE)



SAFETY PRECAUTIONS

READ AND UNDERSTAND ENTIRE SECTION BEFORE OPERATING MACHINE.

⚠ WARNING



• **ELECTRIC SHOCK CAN KILL.** Unless using COLD FEED feature, when feeding with gun trigger, the electrode and drive mechanism are always electrically energized and could remain energized several seconds after the welding ceases..

- Do not attach the work clip to the roll cage or bottom skids. The work clip is energized any time the output of the welding power source is "ON", even when the feeder is not welding.
- Do not touch electrically live part or electrode with skin or wet clothing.
- Insulate yourself from work and ground.
- Always wear dry insulating gloves.
- The serviceability of a product or structure utilizing the LN-15 wire feeder is and must be the sole responsibility of the builder/user. Many variables beyond the control of The Lincoln Electric Company affect the results obtained in using the LN-15 wire feeder. These variables include, but are not limited to, welding procedure, plate chemistry and temperature, weldment design, fabrication methods and service requirements. The available range of the LN-15 wire feeder may not be suitable for all applications, and the builder/user is and must be solely responsible for welding settings.



• **FUMES AND GASSES** can be dangerous.

- Keep your head out of fumes.
- Use ventilation or exhaust at the arc, or both, to remove fumes and gases from breathing zone and general area.



• **WELDING SPARKS** can cause fire or explosion.

- Keep flammable material away.



ARC RAYS can burn.

- Wear eye, ear and body protection.

SEE ADDITIONAL WARNING INFORMATION UNDER ARC WELDING SAFETY PRECAUTIONS AND IN THE FRONT OF THIS OPERATING MANUAL.

GRAPHIC SYMBOLS THAT APPEAR ON THIS MACHINE OR IN THIS MANUAL



INPUT POWER



ON



OFF



WIRE FEEDER



POSITIVE OUTPUT



NEGATIVE OUTPUT



INPUT POWER



DIRECT CURRENT

U_0

OPEN CIRCUIT VOLTAGE

U_1

INPUT VOLTAGE

U_2

OUTPUT VOLTAGE

I_1

INPUT CURRENT

I_2

OUTPUT CURRENT



PROTECTIVE GROUND



WARNING OR CAUTION

GENERAL DESCRIPTION

The LN-15 is a light weight, portable, durable semi-automatic wire feeder.

The LN-15 accommodates spools 8" (200mm) diameter up to 4" (100mm) wide.

The domestic feeders comes factory equipped with a K1500-2 Magnum Tweco-compatible style #2-#4 gun bushing. Other K1500 series gun bushings are available as field installed options. European models are factory equipped with a Fast-Mate adapter.

The wire drive is capable of operating in either a "CV" or "CC" mode. A constant voltage (CV) power source is recommended for flux-cored arc welding (FCAW) and gas metal arc welding (GMAW) to obtain code quality results. However, the LN-15 may also be used with a constant current (CC) power source to obtain passable results for non-critical quality applications.

The "dual procedure" mode drops the WFS to 83% of the original set point. The voltage setting remains the same.

- Burn-back is adjustable from 0.0 to 0.25 seconds, with a default of 0.00 seconds.
- The preflow time is adjustable from 0.00 to 25.0 seconds, with a default of 0.00 seconds.
- The postflow time is adjustable from 0.0 to 25.0 seconds, with a default setting of 0.0 seconds.

The Control Cable Model features remote voltage control with a potentiometer on the front of the feeder. The operation of the voltage control is similar to other feeders having "remote control" kits, such as the LN-25. While welding, the voltage may be adjusted as desired. The voltage setting is not a "preset" value.

Electrode output is energized in response to the gun trigger by signals sent to the power source via the control cable.

DUTY CYCLE

The LN-15 wire feeders are intended for semi-automatic use. The maximum rating of the LN-15 is based upon a 60% duty cycle; 6 minutes of welding followed by 4 minutes of idling within a 10 minute period.

RECOMMENDED PROCESSES

The LN-15 wire drive feeds electrode for various processes as defined below in Table B.1.

The Control Cable Model is suitable for GMAW, GMAW-Pulse, GMAW-STT and FCAW semi-automatic applications within the rated duty cycle.

PROCESS LIMITATIONS

- The control cable model is not recommended for SAW, SMAW, GTAW or CAG.
- The control cable model works only with power sources having remote control output.

EQUIPMENT LIMITATIONS

Codes 11033 and higher

- The LN-15 cannot be used with the K1500-4 gun adapter bushing.

OPERATIONAL FEATURES AND CONTROLS

- Remote voltage control at the LN-15.
- Built in flow meter for adjusting shielding gas.
- Cold Feed/Gas Purge switch.
- 2 step / Trigger Interlock switch (codes 11033 and above only)
- Digital wire feed speed control.
- Digital display of welding voltage.
- Adjustable preflow and postflow times
- Adjustable burnback times.
- ON / OFF switch (codes 11033 and above only)

TABLE B.1

Process	Wire Diameter Range	Wire Feed Speed Range
GMAW	0.023 - 0.052" (0.6 - 1.3 mm)	50 - 700 ipm (1.3 - 17.8 m/minute)
FCAW	0.045 - 0.052" (1.2 - 1.3 mm)	50 - 700 ipm (1.3 - 17.8 m/minute)
FCAW	1/16 - 5/64" (1.6 - 2.0 mm)	50 - 400 ipm (1.3 - 10.2 m/minute)

LN-15 CONTROL CABLE MODEL (CE)



**CASE FRONT CONTROLS (See Figure B.1)
ACROSS THE ARC MODEL**

1. WIRE FEED SPEED DISPLAY-The Wire Feed Speed display shows the rate the LN-15 will feed electrode during welding. The default WFS units for domestic models are inches/minute and can be changed to meters/minute through the configuration menu. The default WFS units for the European models are m/min. The wire feed speed is calibrated to within ±2%.

2. VOLTAGE DISPLAY-The voltage display shows the average arc voltage during the welding. A minus sign "-" appears when welding with electrode negative welding procedures. While welding, an LED will illuminate below the voltage display. After welding, the average voltage will continue to be shown for 5 seconds after the end and the LED will flash. of the weld. When not welding, the display shows "- - -". The voltage is calibrated to ±2% over a range of 10 to 45 volts.

The voltage display is not a "preset" voltage. Refer to the examples from Figure B.1a.

3. WIRE FEED SPEED KNOB-The Wire Feed Speed knob is a 3-3/4 turn potentiometer that adjusts of the rate of feeding electrode. The wire feed speed range is 50 - 700 inches/min (1.3 - 17.8 m/min)

4. VOLTAGE KNOB-The voltage knob is present only on control cable models.

Adjusting the voltage knob varies the power source voltage to the LN-15. The value displayed is not a "preset" voltage. Only actual average arc voltage is shown on the voltage display.

For codes 10864, 10865:

The voltage knob controls the output of the power source through a 3-3/4 turn, 10K ohm potentiometer.

For codes 11033 and above:

The voltage knob controls the output of the power source through a _ turn, 10K ohm potentiometer.

5. TRIGGER CONNECTOR-5 Pin Receptacle is used to activate the Magnum Gun Switch.

6. CONNECTOR BUSHING-This connection is for welding conductor cable assembly.

7. ON / OFF SWITCH-For codes 11033 and above: The ON / OFF Switch turns power on and off to the wire feeder.

83% PROCEDURE

The LN-15 supports a special "dual procedure" mode. When activated, the wire feed speed is reduced to 83% of the set value, but no less than 50 inches/minute (1.27 m/min). The 83% procedure is most commonly used during pipe and out of position welding. Requires Magnum 400 Dual Procedure Gun Equivalent.

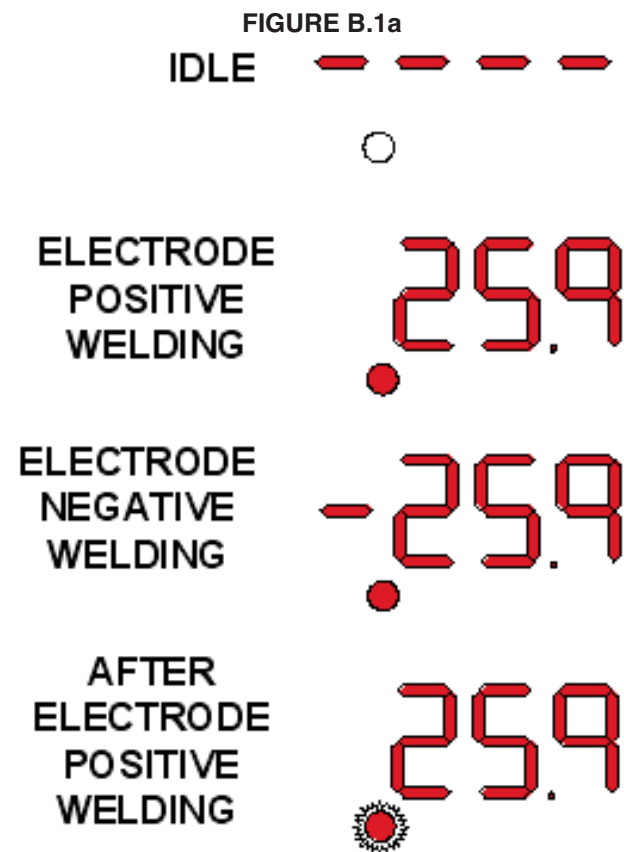
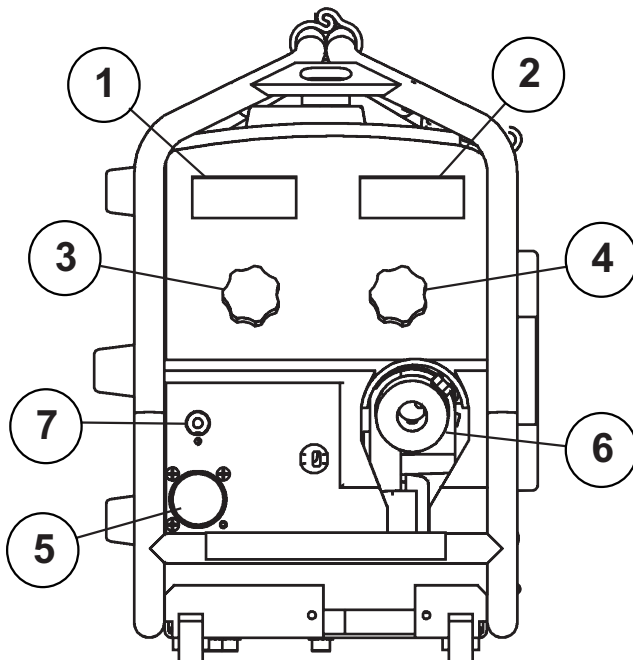

FIGURE B.1a

FIGURE B.1



LN-15 CONTROL CABLE MODEL (CE)



LN-15 POWER-UP SEQUENCE

Normal Power-Up Display

When power is first applied to the LN-15, the display will momentarily show set-up information. For example, it may show "CV" and "HI", indicating operation from a CV power source and the wire drive is configured for the high speed gear. Because of limitations in the display, "CV" will appear as "Cu".



After a brief moment, the LN-15 will then display the WFS and "---". No voltage is displayed until the trigger is pressed.



Preflow, Postflow and Burnback Times

Preflow, Postflow and Burnback times are all adjustable on the LN-15. The LN-15 is factory set with all the times set to 0.0 seconds.

- The burnback time is adjustable from 0.00 to 0.25 seconds.
- The preflow time is adjustable from 0.0 to 25.0 seconds.
- The postflow time is adjustable from 0.0 to 25.0 seconds.

Changing Preflow, Postflow or Burnback times:

1. Enter the "Press Spin" Set-Up Mode:
While the power to the LN-15 is off, activate and hold the GAS PURGE switch (Down Position). Turn on power to the LN-15, and continue to hold the GAS PURGE switch until the LN-15 displays "Press spin". Release the GAS PURGE switch.



The LN-15 is now in the "Press Spin" set-up mode. If after 15 seconds no other action is taken, the LN-15 will then revert to normal operation.

2. Rotate the WFS knob until the desired timer is displayed.



3. Activate and then release the GAS PURGE switch to select the timer. The time will then display in the right hand side of the display. Example:



4. Rotate the WFS knob to adjust the time to the new setting.



5. Press the GAS PURGE switch again to save the setting. The LN-15 will then return to the original "Press Spin" mode in step 1.
6. To exit the "Press Spin" set-up mode, turn off power to the LN-15, or simply wait 15 seconds and the LN-15 will enter normal operation.

Welding Mode CV/CC mode and WFS units

The CV/CC mode and WFS units are all readily changed during the power-up sequence. The LN-15 is factory set for "CV" welding power sources and "inches per minute" for the wire feed speed units.

- The CV/CC mode is selectable for either CV for Constant Voltage power sources and CC for Constant Current power sources. Use CV power sources when making critical welds.
- The WFS units is selectable for either in/min and m/min.

Changing the CV/CC mode, or WFS units:

1. Enter the "Press Spin" Set-Up Mode:
While the power to the LN-15 is off, activate and hold the GAS PURGE switch (Down Position). Turn on power to the LN-15, and continue to hold the GAS PURGE switch until the LN-15 displays "Press spin". Release the GAS PURGE switch.



The LN-15 is now in the "Press Spin" set-up mode. If after 15 seconds no other action is taken, the LN-15 will then revert to normal operation.

LN-15 CONTROL CABLE MODEL (CE)

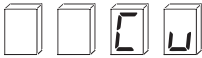
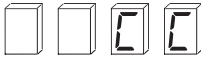

Rotate the WFS knob until the desired parameter is displayed.

CV/CC Mode:  

WFS Units:  

2. Activate and release the GAS PURGE switch to select the parameter. The present value will then display in the right hand side of the display.
Example:

3. Rotate the WFS knob to change the parameter setting.



CV/CC Mode:

- "CU" for Constant Voltage power sources
- "CC" for Constant Current power sources

WFS Units:

- "US" for in/min
- "Eur" for m/min

4. Press the GAS PURGE switch to save the setting. The LN-15 will then return to the original "Press Spin" mode in step 1.

5. To exit the "Press Spin" set-up mode, turn off power to the LN-15, or simply wait 15 seconds and the LN-15 will enter normal operation.

INTERNAL CONTROLS (Figure B.2)

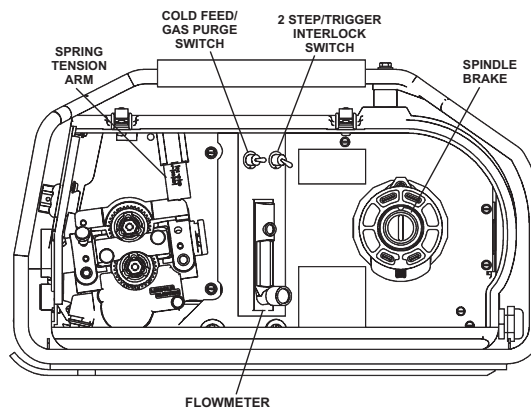

SPRING TENSION ARM

The pressure arm controls the amount of force the drive rolls exert on the wire. Proper adjustment of both pressure arm gives the best welding performance. For best results, set both pressure arms to the same value.

Set the pressure arm as follows (See Figure B.2a):

- Aluminum wires between 1 and 3
- Cored wires between 3 and 4
- Steel, Stainless wires between 4 and 6

Figure B.2a

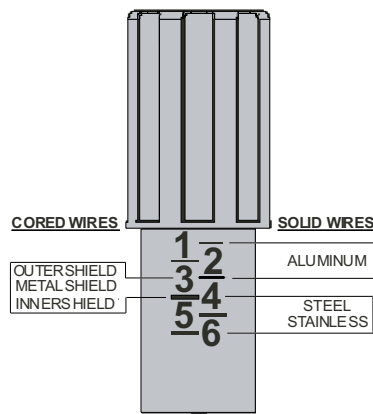

WIRE DRIVE CONFIGURATION

(See Figure B.2b)

Changing the Gun Receiver Bushing



ELECTRIC SHOCK can kill.

- Turn the input power **OFF** at the welding power source before installation or changing drive rolls and/or guides.
- Do not touch electrically live parts.
- When inching with the gun trigger, electrode and drive mechanism are "hot" to work and ground and could remain energized several seconds after the gun trigger is released.
- Only qualified personnel should perform maintenance work.

Tools required:

- 1/4" hex key wrench.

Note: Some gun bushings do not require the use of the thumb screw.

1. Turn power off at the welding power source.
2. Remove the welding wire from the wire drive.
3. Remove the thumb screw from the wire drive.
4. Remove the welding gun from the wire drive.
5. Loosen the socket head cap screw that holds the connector bar against the gun bushing.

Important: Do not attempt to completely remove the socket head cap screw.

6. Remove the outer wire guide, and push the gun bushing out of the wire drive. Because of the precision fit, light tapping may be required to remove the gun bushing.
7. Disconnect the shielding gas hose from the gun bushing, if required.
8. Connect the shielding gas hose to the new gun bushing, if required.
9. Rotate the gun bushing until the thumb screw hole aligns with the thumb screw hole in the feed plate. Slide the gun receiver bushing into the wire drive and verify the thumb screw holes are aligned.
10. Tighten the socket head cap screw.
11. Insert the welding gun into the gun bushing and tighten the thumb screw.

COLD FEED/GAS PURGE SWITCH

Cold Feed and Gas Purge are combined into a single spring centered toggle switch.

To activate Cold Feeding, hold the switch in the UP position. The wire drive will feed electrode but neither the power source nor the gas solenoid will be energized. Adjust the speed of cold feeding by rotating the WFS knob. Cold feeding, or "cold inching" the electrode is useful for threading the electrode through the gun.

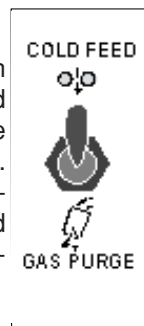
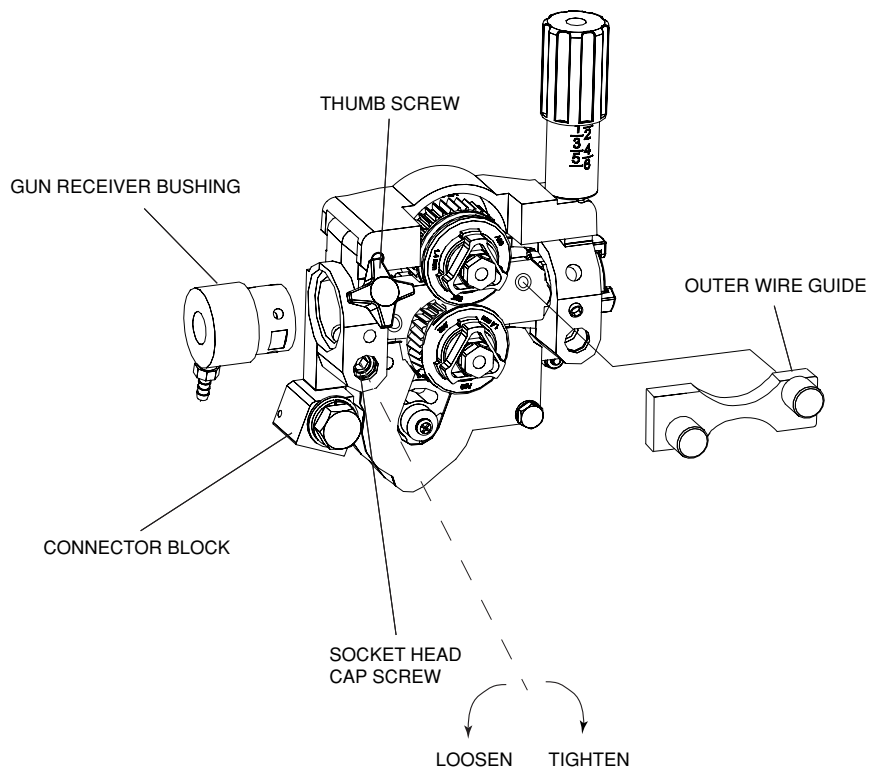

FIGURE B.2b



LN-15 CONTROL CABLE MODEL (CE)



Hold with toggle switch in the DOWN position to activate Gas Purge and let the shielding gas flow. The gas solenoid valve will energize but neither the power source output nor the drive motor will be turned on. The Gas Purge switch is useful for setting the proper flow rate of shielding gas. Flow meters should always be adjusted while the shielding gas is flowing.

2 STEP - TRIGGER INTERLOCK SWITCH

The 2 Step - Trigger Interlock switch changes the function of the gun trigger. 2 Step trigger operation turns welding on and off in direct response to the trigger. Trigger Interlock operation allows welding to continue when the trigger is released for comfort on long welds.

Place the toggle switch in the UP position for 2 Step operation or in the DOWN position for Trigger Interlock operation.

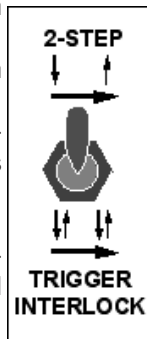

2 Step Trigger

2 Step trigger operation is the most common. When the gun trigger is pulled, the welding power source energizes the electrode output and the wire feeder feeds wire for welding. The power source and wire feeder continue welding until the trigger is released.

Trigger Interlock

Trigger Interlock operation provides for operator comfort when making long welds. When the gun trigger is first pulled, the welding power source energizes the output and the wire feeder feeds wire for welding. The gun trigger is then released while the weld is made. To stop welding, the gun trigger is pulled again, and when it is released the welding power source output turns off and the wire feeder stops feeding wire.

CAUTION

If the arc goes out while welding with trigger interlock operation, the electrode output from the welding power source remains energized and the wire feeder will continue to feed wire until the gun trigger is again pulled and then released.

FLOW METER

The flowmeter shows the flow rate of shielding gas and has a valve to adjust the flow. The flow meter is calibrated for CO₂, Ar, and CO₂/Ar blends. The middle of the ball indicates the flow rate of shielding gas.

Adjust the flow rate by turning the valve at the bottom of the meter. Most weld procedures require 25-40 scfh (11.8 - 18.9 lpm) for sufficient shielding gas coverage. Gun angle, nozzle diameter, joint configuration and wind conditions may effect the amount of shielding gas required.

SCFH	Liter/Min.
10	4.7
20	9.4
30	14.2
40	18.9
50	23.6
60	28.3
70	33.1
80	37.8

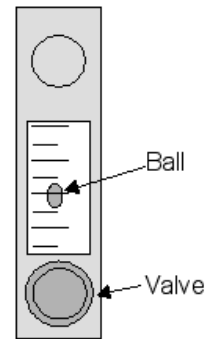

SPINDLE BRAKE

Adjust the spindle brake tension to allow the spool to spin freely, yet have enough resistance for little or no overrun when wire feeding is stopped.

SHIELDING GAS CONNECTION

WARNING



CYLINDER may explode if damaged.

- Keep cylinder upright and chained to support.

- Keep cylinder away from areas where it may be damaged.
- Never lift welder with cylinder attached.
- Never allow welding electrode to touch cylinder.
- Keep cylinder away from welding or other live electrical circuits.

WARNING

- BUILD UP OF SHIELDING GAS MAY HARM HEALTH OR KILL.
- Shut off shielding gas supply when not in use.
- See American National Standard Z-49.1, "Safety in Welding and Cutting" Published by the American Welding Society.

Customer must provide a cylinder of shielding gas, a pressure regulator, a flow control valve and a hose from the flow valve to the gas inlet fitting of the LN-15.

Connect a supply hose from the gas cylinder flow valve outlet to the 5/8-18 female inert gas fitting on the back of the LN-15.

LN-15 CONTROL CABLE MODEL (CE)



CONSTANT CURRENT OPERATION

(See Figure B.3)

⚠ CAUTION

Lincoln Electric does NOT recommend constant current semiautomatic welding for applications which need to meet specified weld metal chemical or mechanical property requirements or weld quality requirements.

Most semiautomatic welding processes perform better using constant voltage power sources.

Welding codes usually do not address the power source selection or specifically, whether the welding process is to be operated in the constant voltage or constant current mode. Instead, codes typically specify limitations on the current, voltage, heat input and preheat temperature based on the material to be welded. The intention is to assure that proper weld material properties will develop.

Welding is sometimes performed using constant current power sources. The operation can be more convenient because it may allow the use of an existing stick (SMAW) power source and the power source can be placed at a distant location without any provision for adjusting the output settings.

For constant current operation, the power source is set to deliver the specified current. The power source regulates this current regardless of changes in the welding circuit, including cable length, electrode diameter, wire feed speed, contact tip to work distance, etc.

Changes in the wire feed speed (WFS) or contact tip to work distance (CTWD) affect the arc voltage when constant current power sources are used. Lowering the wire feed speed raises the voltage, raising the wire feed speed lowers the voltage. Lengthening the contact tip to work distance raises the voltage, shortening the contact tip to work distance lowers the voltage.

If the contact tip to work distance is properly maintained, a satisfactory operating voltage range may be achieved, and a sound weld may result. However, when a welder uses a longer contact tip to work distance, an arc-sensing wire feeder compensates by increasing the wire feed speed to regulate the voltage. Even if the voltage and current remain unchanged, the increased wire feed speed may result in a deposition rate well beyond the specified range of the electrode. Under these conditions, the specified weld metal properties may not be achieved.

Constant voltage power sources deliver large current surges to stabilize the arc when the electrode is shorted or the arc length is very short. However, a constant current power source does not provide such a response to stabilize the arc. It may be difficult to achieve required weld metal properties, or to achieve the required quality of welds needed to pass non-destructive tests, when such welds are made under constant current operation.

FIGURE B.3

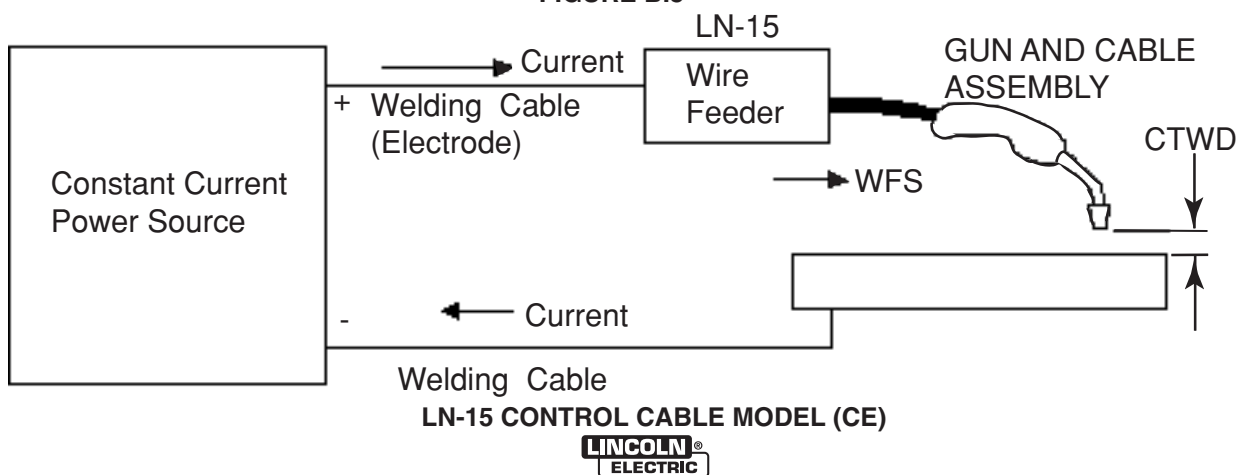

SETTING ARC SENSING WIRE FEED SPEED FOR CONSTANT CURRENT OPERATION

When using a constant current (formerly variable voltage) power source, welding performance is improved using arc sensing wire feed speed (CC operation). In this wire feed mode the wire speed increases if arc voltage increases, and decreases if arc voltage decreases, but remains constant at any specific voltage level.

The LN-15 permits accurate presetting of the desired wire feed speed, for the desired arc voltage to be used, by setting the Wire Feed Speed in the following manner before welding:

- a. Activate press and spin during power up and change to the CC mode. See "Changing the CV/CC mode or WFS units" in this Operation Section.

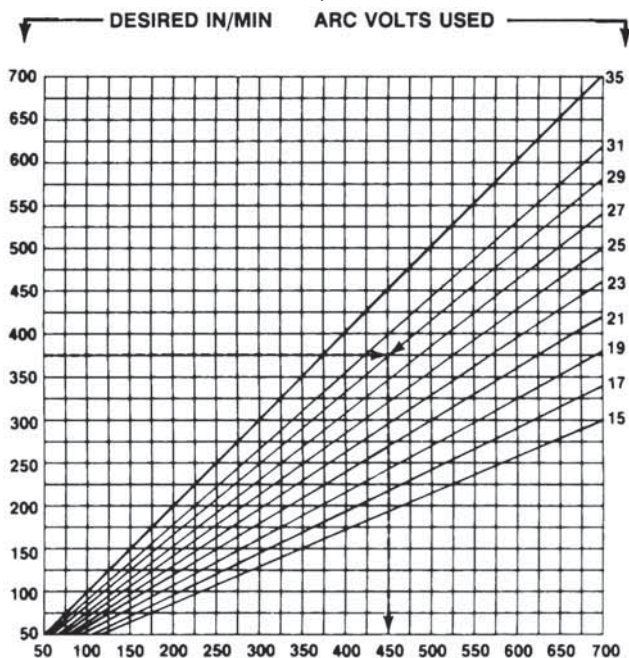

FIGURE B.4 CC WIRE SPEED SETTING

- b. Referring to the graph located above the Mode switch (also shown in Figure B.4):
 1. Select the horizontal line representing the DESIRED IN/MIN. for the welding procedure. (See example arrow line for 375 in/min.)
 2. Select the diagonal line representing the ARC VOLTS to be used for the welding procedure. (See example arrow line for 29 volts.)
 3. Determine the vertical line representing the CC WIRE SPEED SETTING where the above two lines cross. (See example arrow line for 450.)
- c. Adjust the WFS display to the value determined in Step (3) above (450 for example used).

The wire will feed at the DESIRED IN/MIN speed when the welding power source is set to the arc voltage to be used for the weld procedure (375 in/min. at 29V for example used).

The CC wire speed setting graph is shown in TABLE B.1, giving the Wire Speed dial setting required for the DESIRED IN/MIN and ARC VOLTS used for the welding procedures:

TABLE B.1 CC WIRE SPEED SETTING

Desired In/Min	Arc Volts Used									
	16	18	20	22	24	26	28	30	32	34
50	109	97	88	80	73	67	63	58	55	51
60	131	117	105	95	88	81	75	70	66	62
70	153	136	123	111	102	94	88	82	77	72
80	175	156	140	127	117	108	100	93	88	82
90	197	175	158	143	131	121	113	105	98	93
100	219	194	175	159	146	135	125	117	109	103
110	241	214	193	175	160	148	138	128	120	113
120	263	233	210	191	175	162	150	140	131	124
130	284	253	228	207	190	175	163	152	142	134
140	306	272	245	223	204	188	175	163	153	144
150	328	292	263	239	219	202	188	175	164	154
160	350	311	280	255	233	215	200	187	175	165
170	372	331	298	270	248	229	213	198	186	175
180	394	350	315	286	263	242	225	210	197	185
190	416	369	333	302	277	256	238	222	208	196
200	438	389	350	318	292	269	250	233	219	206
210	459	408	368	334	306	283	263	245	230	216
220	481	428	385	350	321	296	275	257	241	226
230	503	447	403	366	335	310	288	268	252	237
240	525	467	420	382	350	323	300	280	263	247
250	547	486	438	398	365	337	313	292	273	257
260	569	506	455	414	379	350	325	303	284	268
270	591	525	473	430	394	365	338	315	295	278
280	613	544	490	445	408	377	350	327	306	288
290	634	564	508	461	423	390	363	338	317	299
300	656	583	525	477	438	404	375	350	328	309
310	678	603	543	493	452	417	388	362	339	319
320	700	622	560	509	467	431	400	373	350	329
330		642	578	525	481	444	413	385	361	340
340		661	595	541	496	458	425	397	372	350
350		681	613	557	510	471	438	408	383	360
360		700	630	572	526	484	450	420	394	370
380			666	604	554	512	472	444	416	392
400			700	636	584	538	500	466	438	412
420				668	612	566	526	490	460	432
440				700	642	592	550	514	482	452
460					670	620	576	536	504	472
480					700	646	600	560	526	494
500						674	626	584	546	514
520						700	650	606	568	536
540							676	630	590	556
560							700	654	612	576
580								676	634	598
600								700	656	618
620									678	638
640									700	658
660										680
680										700
700										700

CC Speed Setting = $\frac{\text{Desired IPM}}{\text{Arc Volts}} \times 35$

LN-15 CONTROL CABLE MODEL (CE)



MAKING A WELD

The serviceability of a product or structure utilizing the LN-15 wire feeder is and must be the sole responsibility of the builder/user. Many variables beyond the control of The Lincoln Electric Company affect the results obtained in using the LN-15 wire feeder. These variables include, but are not limited to, welding procedure, plate chemistry and temperature, weldment design, fabrication methods and service requirements. The available range of the LN-15 wire feeder may not be suitable for all applications, and the builder/user is and must be solely responsible for welding settings.

- Close the door on the LN-15.
- Connect the work cable to the metal to be welded. The work cable must make good electrical contact to the work. The work must also be grounded as stated in "Arc Welding Safety Precautions".
- Connect the LN-15 electrode cable to the power source for the polarity and process to be used. Check that the appropriate power source settings are made for the procedure to be used. (Refer to the power source operating and connection instructions.)
- Place the LN-15 conveniently near the work area in a safe location to minimize exposure to weld spatter and to avoid sharp bends in the gun cable.
- Connect the LN-15 work clip to the work.
- Be sure the proper contact tip for the wire size being used is in the gun.
- Turn on the welding power source, as well as the shielding gas supply (if used.)
- Cut the electrode within approximately 3/8" (10mm) of the end of the contact tip for solid wire and within 3/4" (19mm) of the extension guide for cored wire.
- Position the electrode over the joint. The end of the electrode should be slightly off the work.
- Lower welding helmet, close the gun trigger and begin welding. Hold the gun so the contact tip to work distance gives the correct electrical stickout as required for the procedure being used.
- To stop welding, release the gun trigger and the pull the gun away from the work.

LN-15 CONTROL CABLE MODEL (CE)



OPTIONAL EQUIPMENT

- K1797-[] control cable extensions
- K1798 Adapter Cable for Control Cable to Terminal Strip Power Sources
- K1500-1, -2, -3, -5 Gun Receiver Bushings

- Drive Roll Kits (Include drive rolls and guide tube necessary to feed the identified wire size and type.

WIRE TYPE	ELECTRODE SIZE	KP KIT
Steel Wires: (Including stainless steel)	.023-.030" (0.6-0.8mm)	KP1696-030S
	.035" (0.9mm)	KP1696-035S
	.040-.045" (1.0-1.2mm)	KP1696-045S
	.052" (1.4mm)	KP1696-052S
	.035-.045" (0.9-1.2mm)	KP1696-1
	.040" (1.0mm)	KP1696-2
Cored Wires:	.030-.035" (0.8-0.9mm)	KP1697-035C
	.040-.045" (1.0-1.2mm)	KP1697-045C
	.052" (1.4mm)	KP1697-052C
	1/16" (1.6mm)	KP1697-1/16C
	.068" (1.7mm)	KP1697-068
	5/64" (2.0mm)	KP1697-5/64
Aluminum Wires:	.035" (0.9mm)	KP1695-035A
	.040" (1.0mm)	KP1695-040A
	3/64" (1.2mm)	KP1695-3/64A

⚠ WARNING

ELECTRIC SHOCK can kill.



- Do not operate with covers removed.
 - Turn off power source before installing or servicing.
 - Do not touch electrically hot parts.
-
- Turn the input power to the welding power source off at the fuse box before working in the terminal strip.
 - Only qualified personnel should install, use or service this equipment.

ROUTINE MAINTENANCE

Routine maintenance consists of periodically blowing out the machine, using a low pressure airstream, to remove accumulated dust and dirt from inside the feeder.

PERIODIC MAINTENANCE

- Replace the drive rolls and inner wire guide when they are worn.
- Replace the pig tail if the insulation is cut, abraded or damaged.

CALIBRATION SPECIFICATION

All calibration is factory set on the LN-15.

To verify the wire feed speed:

- Assemble a .045 (1.2mm) drive roll kit into the LN-15.
- Load a spool of .045 (1.2mm) electrode and thread the electrode through the wire drive.
- Adjust the wire feed speed to 300 in/min (7.62m/min).
- Press the COLD INCH switch and measure the actual wire feed speed with a calibrated wire feed speed tachometer.
- The measured wire feed speed should be within 2% of the set value.

To verify the voltage display:

- Set the welding power source and LN-15 to a CV procedure that gives steady "spray" transfer in the arc.
- While a weld is being made, measure the voltage from the feedplate to work.
- The displayed voltage on the LN-15 should be within 2% of the measured value.

LN-15 CONTROL CABLE MODEL (CE)



HOW TO USE TROUBLESHOOTING GUIDE

WARNING

Service and Repair should only be performed by Lincoln Electric Factory Trained Personnel. Unauthorized repairs performed on this equipment may result in danger to the technician and machine operator and will invalidate your factory warranty. For your safety and to avoid Electrical Shock, please observe all safety notes and precautions detailed throughout this manual.

This Troubleshooting Guide is provided to help you locate and repair possible machine malfunctions. Simply follow the three-step procedure listed below.

Step 1. LOCATE PROBLEM (SYMPTOM).

Look under the column labeled "PROBLEM (SYMPTOMS)". This column describes possible symptoms that the machine may exhibit. Find the listing that best describes the symptom that the machine is exhibiting.

Step 2. POSSIBLE CAUSE.

The second column labeled "POSSIBLE CAUSE" lists the obvious external possibilities that may contribute to the machine symptom.

Step 3. RECOMMENDED COURSE OF ACTION

This column provides a course of action for the Possible Cause, generally it states to contact your local Lincoln Authorized Field Service Facility.

If you do not understand or are unable to perform the Recommended Course of Action safely, contact your local Lincoln Authorized Field Service Facility.

CAUTION

If for any reason you do not understand the test procedures or are unable to perform the tests/repairs safely, contact your **Local Lincoln Authorized Field Service Facility** for technical troubleshooting assistance before you proceed.

Observe all Safety Guidelines detailed throughout this manual

PROBLEMS (SYMPTOMS)	POSSIBLE CAUSE	RECOMMENDED COURSE OF ACTION
OUTPUT PROBLEMS		
Major physical or electrical damage is evident when the sheet metal covers are removed.	1. Contact your local authorized Lincoln Electric Field Service facility for technical assistance.	If all recommended possible areas of misadjustment have been checked and the problem persists, Contact your local Lincoln Authorized Field Service Facility.
The wire drive turns off periodically while operating on an engine drive.	1. The supply voltage for the LN-15 is too low.	
No shielding gas flow.	1. The gas bottle empty. 2. The gas hose is cut or clogged. 3. The flow meter valve is closed. 4. The gas solenoid has failed 5. The feed head board has failed.	
The shielding gas turns on sporadically, or remains on all the time.	1. The pressure in the gas line is exceeding 80 psi (5.5 bar) 2. The gas solenoid has failed.	
FEEDING PROBLEM		
The wire drive stops feeding wire after about 10 seconds.	1. The motor has exceeded the current rating. 2. Check to make sure the electrode slides easily through the liner of the gun. 3. Verify that the spindle brake is not set too tight. 4. For best results, use only Lincoln electrodes. 5. Wait 10 minutes for the wire feeder to cool.	If all recommended possible areas of misadjustment have been checked and the problem persists, Contact your local Lincoln Authorized Field Service Facility.
The wire feed speed varies during welding but the meter reading remains constant	1. The drive rolls are slipping because of feeding problems. 2. The LN-15 is in CC mode instead of CV mode. 3. Reduce the spindle brake resistance. 4. Increase the amount of tension in the wire drive pressure arm. 5. For best results, use only Lincoln electrodes. 6. Verify on power-up that the LN-15 is set for CV welding.	
The Wire Feed Speed Range is only 50 - 601 in/min (1.3 - 15.3 m/min).	1. The 83% wire feed speed dual procedure is activated with the high speed gear. Check dual procedure switch in gun.	

 **CAUTION**

If for any reason you do not understand the test procedures or are unable to perform the tests/repairs safely, contact your **Local Lincoln Authorized Field Service Facility** for technical troubleshooting assistance before you proceed.

LN-15 CONTROL CABLE MODEL (CE)



Observe all Safety Guidelines detailed throughout this manual

PROBLEMS (SYMPTOMS)	POSSIBLE CAUSE	RECOMMENDED COURSE OF ACTION
The Wire Feed Speed Range is only 50 - 374 in/min (1.3 - 9.5 m/min)	1. The 83% wire feed speed dual procedure is activated with the low speed gear. Check dual procedure switch in gun.	
DISPLAY PROBLEMS		
"POS", "PRE" or "BRN" show on the display.	1. The LN-15 is in the Press and Spin set-up mode. 2. One of the DIP switches on the feed head board is set to "ON" for timer setting mode. 3. Cycle power to the LN-15 or wait 45 seconds. 4. The LN-15 is an old ALPHA unit and a DIP switch is in the wrong position.	If all recommended possible areas of misadjustment have been checked and the problem persists, Contact your local Lincoln Authorized Field Service Facility.
The voltage display reads "0.0" volts during welding	1. The power source meter polarity switch is in the wrong position. 2. Set the power source meter polarity switch to match the welding process.	
WELDING PROBLEMS		
Porosity in the weld. Variable or "hunting" arc.	1. The part being welded is wet, dirty or rusty. 2. The electrode being used is wet, dirty or rusty. 3. There is insufficient shielding gas flow from possible cuts in the gas hose 4. There is moisture or water in the shielding gas line. 5. There is too much shielding gas 6. There is too much wind or drafts. 7. The arc voltage is set too high. 8. The wrong shielding gas is being used.	If all recommended possible areas of misadjustment have been checked and the problem persists, Contact your local Lincoln Authorized Field Service Facility.
Variable or "hunting" arc.	1. Worn and/or melted contact tip. 2. Worn work cable or poor work connection. 3. Loose electrode connection. 4. Wrong electrode polarity for the process being used.	
The arc burns back to the tip.	1. The spool of electrode is tangled. 2. The electrode and work leads are reversed (welding with the wrong polarity.) 3. The liner is clogged. 4. The contact tip is worn. 5. The wire drive tension is improperly set.	

 **CAUTION**

If for any reason you do not understand the test procedures or are unable to perform the tests/repairs safely, contact your **Local Lincoln Authorized Field Service Facility** for technical troubleshooting assistance before you proceed.

LN-15 CONTROL CABLE MODEL (CE)



Observe all Safety Guidelines detailed throughout this manual

ERRORS ON THE DISPLAY

Fault Code	Description	Possible Adjustments
Err 0081	Average motor over current shutdown	<ul style="list-style-type: none"> • The wire drive motor has overheated. • Check to make sure the electrode slides easily through the liner of the gun. • Reduce the amount of tension in the wire drive tension arm. • Verify that the spindle brake is not set too tight. • For best results, use only Lincoln electrodes. • Wait 10 minutes for the wire feeder to cool.
Err 0086	Trigger lockout.	<ul style="list-style-type: none"> • The ripple of the power source OCV is too high, greater than 110V. (Across the Arc Models only) • Verify the power source is reconnected for the proper input voltage. • Repair or replace the power source. The power source does not conform to NEMA

CAUTION

If for any reason you do not understand the test procedures or are unable to perform the tests/repairs safely, contact your **Local Lincoln Authorized Field Service Facility** for technical troubleshooting assistance before you proceed.

LN-15 CONTROL CABLE MODEL (CE)



LN-15 CONTROL CABLE MODEL

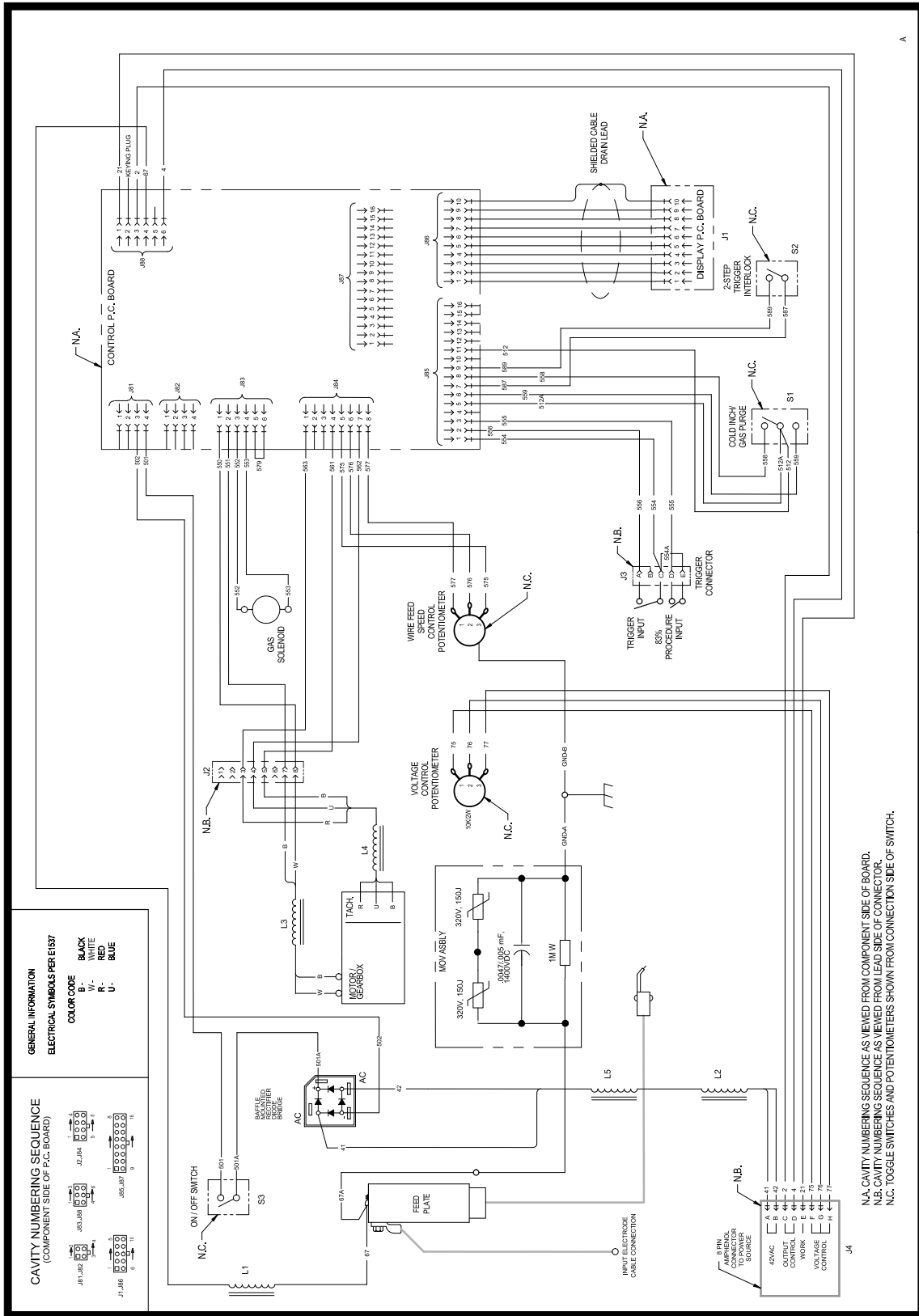

L11657-1

NOTE: This diagram is for reference only. It may not be accurate for all machines covered by this manual. The specific diagram for a particular code is pasted inside the machine on one of the enclosure panels. If the diagram is illegible, write to the Service Department for a replacement. Give the equipment code number.

LN-15 CONTROL CABLE MODEL (CE)



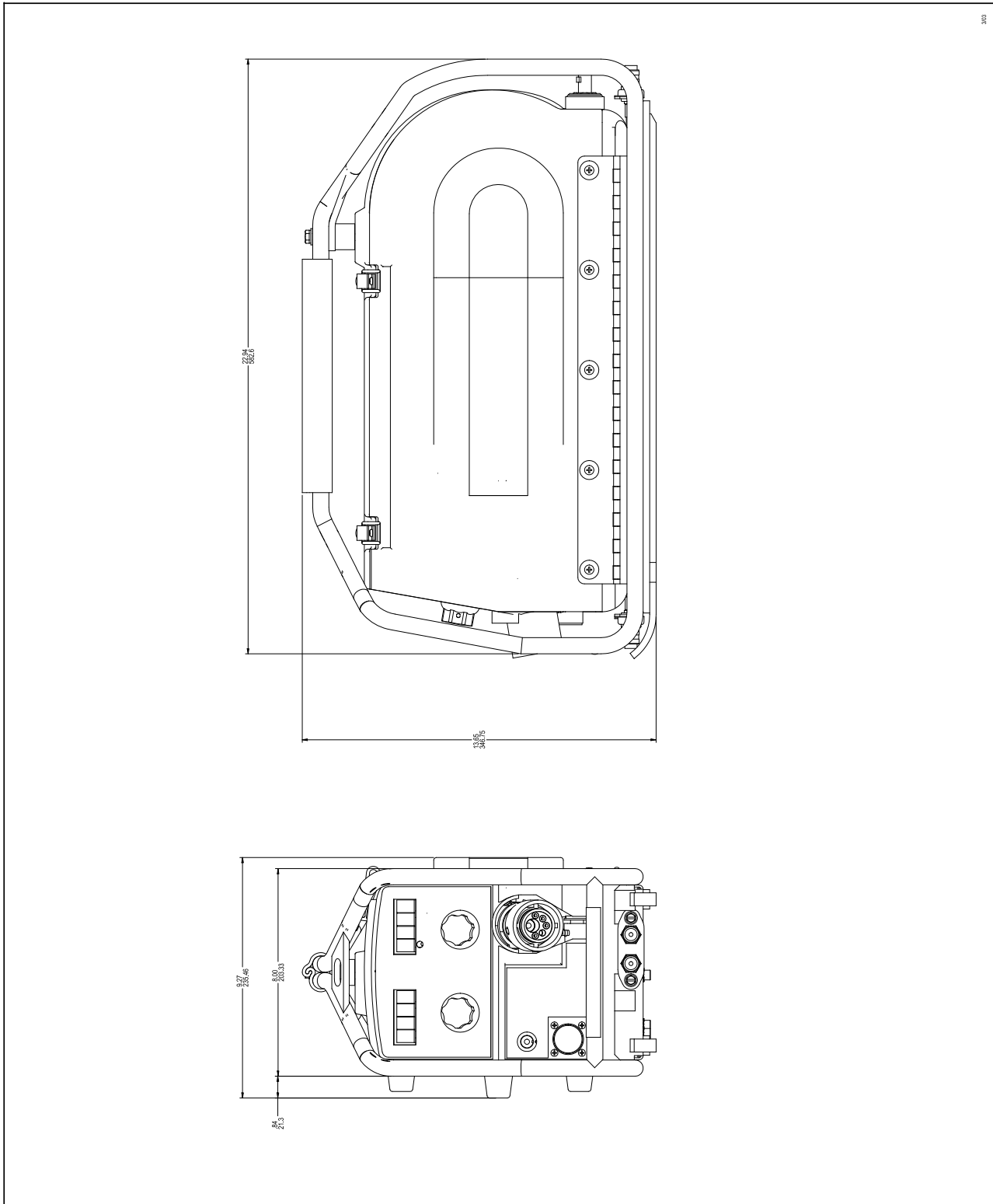

LN-15 CONTROL CABLE MODEL (CE)



NOTES

LN-15 CONTROL CABLE MODEL (CE)



			
WARNING	<ul style="list-style-type: none"> ● Do not touch electrically live parts or electrode with skin or wet clothing. ● Insulate yourself from work and ground. 	<ul style="list-style-type: none"> ● Keep flammable materials away. 	<ul style="list-style-type: none"> ● Wear eye, ear and body protection.
Spanish AVISO DE PRECAUCION	<ul style="list-style-type: none"> ● No toque las partes o los electrodos bajo carga con la piel o ropa mojada. ● Aislese del trabajo y de la tierra. 	<ul style="list-style-type: none"> ● Mantenga el material combustible fuera del área de trabajo. 	<ul style="list-style-type: none"> ● Protégase los ojos, los oídos y el cuerpo.
French ATTENTION	<ul style="list-style-type: none"> ● Ne laissez ni la peau ni des vêtements mouillés entrer en contact avec des pièces sous tension. ● Isolez-vous du travail et de la terre. 	<ul style="list-style-type: none"> ● Gardez à l'écart de tout matériel inflammable. 	<ul style="list-style-type: none"> ● Protégez vos yeux, vos oreilles et votre corps.
German WARNUNG	<ul style="list-style-type: none"> ● Berühren Sie keine stromführenden Teile oder Elektroden mit Ihrem Körper oder feuchter Kleidung! ● Isolieren Sie sich von den Elektroden und dem Erdboden! 	<ul style="list-style-type: none"> ● Entfernen Sie brennbares Material! 	<ul style="list-style-type: none"> ● Tragen Sie Augen-, Ohren- und Körperschutz!
Portuguese ATENÇÃO	<ul style="list-style-type: none"> ● Não toque partes elétricas e electrodos com a pele ou roupa molhada. ● Isole-se da peça e terra. 	<ul style="list-style-type: none"> ● Mantenha inflamáveis bem guardados. 	<ul style="list-style-type: none"> ● Use proteção para a vista, ouvido e corpo.
Japanese 注意事項	<ul style="list-style-type: none"> ● 通電中の電気部品、又は溶材にヒフやぬれた布で触れないこと。 ● 施工物やアースから身体が絶縁されている様にして下さい。 	<ul style="list-style-type: none"> ● 燃えやすいものの側での溶接作業は絶対にしてはなりません。 	<ul style="list-style-type: none"> ● 目、耳及び身体に保護具をして下さい。
Chinese 警告	<ul style="list-style-type: none"> ● 皮肤或湿衣物切勿接触带电部件及焊条。 ● 使你自已与地面和工件绝缘。 	<ul style="list-style-type: none"> ● 把一切易燃物品移离工作场所。 	<ul style="list-style-type: none"> ● 佩戴眼、耳及身体劳动保护用具。
Korean 위험	<ul style="list-style-type: none"> ● 전도체나 용접봉을 젖은 헝겊 또는 피부로 절대 접촉치 마십시오. ● 모재와 접지를 접촉치 마십시오. 	<ul style="list-style-type: none"> ● 인화성 물질을 접근 시키지 마십시오. 	<ul style="list-style-type: none"> ● 눈, 귀와 몸에 보호장구를 착용하십시오.
Arabic تحذير	<ul style="list-style-type: none"> ● لا تلمس الاجزاء التي يسري فيها التيار الكهربائي أو الألكترود بجلد الجسم أو بالملابس المبللة بالماء. ● ضع عازلا على جسمك خلال العمل. 	<ul style="list-style-type: none"> ● ضع المواد القابلة للاشتعال في مكان بعيد. 	<ul style="list-style-type: none"> ● ضع أدوات وملابس واقية على عينيك وأذنيك وجسمك.

READ AND UNDERSTAND THE MANUFACTURER'S INSTRUCTION FOR THIS EQUIPMENT AND THE CONSUMABLES TO BE USED AND FOLLOW YOUR EMPLOYER'S SAFETY PRACTICES.

SE RECOMIENDA LEER Y ENTENDER LAS INSTRUCCIONES DEL FABRICANTE PARA EL USO DE ESTE EQUIPO Y LOS CONSUMIBLES QUE VA A UTILIZAR, SIGA LAS MEDIDAS DE SEGURIDAD DE SU SUPERVISOR.

LISEZ ET COMPRENEZ LES INSTRUCTIONS DU FABRICANT EN CE QUI REGARDE CET EQUIPMENT ET LES PRODUITS A ETRE EMPLOYES ET SUIVEZ LES PROCEDURES DE SECURITE DE VOTRE EMPLOYEUR.

LESEN SIE UND BEFOLGEN SIE DIE BETRIEBSANLEITUNG DER ANLAGE UND DEN ELEKTRODENEINSATZ DES HERSTELLERS. DIE UNFALLVERHÜTUNGSVORSCHRIFTEN DES ARBEITGEBERS SIND EBENFALLS ZU BEACHTEN.

			
<ul style="list-style-type: none"> ● Keep your head out of fumes. ● Use ventilation or exhaust to remove fumes from breathing zone. 	<ul style="list-style-type: none"> ● Turn power off before servicing. 	<ul style="list-style-type: none"> ● Do not operate with panel open or guards off. 	WARNING
<ul style="list-style-type: none"> ● Los humos fuera de la zona de respiración. ● Mantenga la cabeza fuera de los humos. Utilice ventilación o aspiración para gases. 	<ul style="list-style-type: none"> ● Desconectar el cable de alimentación de poder de la máquina antes de iniciar cualquier servicio. 	<ul style="list-style-type: none"> ● No operar con panel abierto o guardas quitadas. 	Spanish AVISO DE PRECAUCION
<ul style="list-style-type: none"> ● Gardez la tête à l'écart des fumées. ● Utilisez un ventilateur ou un aspirateur pour ôter les fumées des zones de travail. 	<ul style="list-style-type: none"> ● Débranchez le courant avant l'entretien. 	<ul style="list-style-type: none"> ● N'opérez pas avec les panneaux ouverts ou avec les dispositifs de protection enlevés. 	French ATTENTION
<ul style="list-style-type: none"> ● Vermeiden Sie das Einatmen von Schweißrauch! ● Sorgen Sie für gute Be- und Entlüftung des Arbeitsplatzes! 	<ul style="list-style-type: none"> ● Strom vor Wartungsarbeiten abschalten! (Netzstrom völlig öffnen; Maschine anhalten!) 	<ul style="list-style-type: none"> ● Anlage nie ohne Schutzgehäuse oder Innenschutzverkleidung in Betrieb setzen! 	German WARNUNG
<ul style="list-style-type: none"> ● Mantenha seu rosto da fumaça. ● Use ventilação e exaustão para remover fumo da zona respiratória. 	<ul style="list-style-type: none"> ● Não opere com as tampas removidas. ● Desligue a corrente antes de fazer serviço. ● Não toque as partes elétricas nuas. 	<ul style="list-style-type: none"> ● Mantenha-se afastado das partes moventes. ● Não opere com os painéis abertos ou guardas removidas. 	Portuguese ATENÇÃO
<ul style="list-style-type: none"> ● ヒュームから頭を離すようにして下さい。 ● 換気や排煙に十分留意して下さい。 	<ul style="list-style-type: none"> ● メンテナンス・サービスに取りかかる際には、まず電源スイッチを必ず切して下さい。 	<ul style="list-style-type: none"> ● パネルやカバーを取り外したまま機械操作をしないで下さい。 	Japanese 注意事項
<ul style="list-style-type: none"> ● 頭部遠離煙霧。 ● 在呼吸區使用通風或排風器除煙。 	<ul style="list-style-type: none"> ● 維修前切斷電源。 	<ul style="list-style-type: none"> ● 儀表板打開或沒有安全罩時不準作業。 	Chinese 警告
<ul style="list-style-type: none"> ● 얼굴로부터 용접가스를 멀리하십시오. ● 호흡지역으로부터 용접가스를 제거하기 위해 가스제거기나 통풍기를 사용하십시오. 	<ul style="list-style-type: none"> ● 보수전에 전원을 차단하십시오. 	<ul style="list-style-type: none"> ● 판넬이 열린 상태로 작동치 마십시오. 	Korean 위험
<ul style="list-style-type: none"> ● ابعد رأسك بعيداً عن الدخان. ● استعمل التهوية أو جهاز ضغط الدخان للخارج لكي تبعد الدخان عن المنطقة التي تتنفس فيها. 	<ul style="list-style-type: none"> ● أقطع التيار الكهربائي قبل القيام بأية صيانة. 	<ul style="list-style-type: none"> ● لا تشغيل هذا الجهاز إذا كانت الإغطية الحديدية الواقية ليست عليه. 	Arabic تحذير

LEIA E COMPREENDA AS INSTRUÇÕES DO FABRICANTE PARA ESTE EQUIPAMENTO E AS PARTES DE USO, E SIGA AS PRÁTICAS DE SEGURANÇA DO EMPREGADOR.

使う機械や溶材のメーカーの指示書をよく読み、まず理解して下さい。そして貴社の安全規定に従って下さい。

請詳細閱讀並理解製造廠提供的說明以及應該使用的銀焊材料，並請遵守貴方的有關勞動保護規定。

이 제품에 동봉된 작업지침서를 숙지하시고 귀사의 작업자 안전수칙을 준수하시기 바랍니다.

اقرأ بتمعن وافهم تعليمات المصنع المنتج لهذه المعدات والمواد قبل استعمالها واتبع تعليمات الوقاية لصاحب العمل.



• World's Leader in Welding and Cutting Products •

• Sales and Service through Subsidiaries and Distributors Worldwide •

Cleveland, Ohio 44117-1199 U.S.A. TEL: 216.481.8100 FAX: 216.486.1751 WEB SITE: www.lincolnelectric.com