



Westermans International Ltd
welding and cutting solutions that don't cost the earth

W: www.westermans.com E: welding@westermans.com

T: +44 (0)116 269 6941



VP10

Fixed Height Welding Positioner



Specification

Model	VP10 Positioner
Capacity	10 Tonne (22,046lb)
C. O. G. / Eccentricity	500mm (19.7") / 300mm (11.8")
Table Diameter	1830mm (72") with 6 x 42mm (1.65") slots
Table Height (Horizontal)	1550mm (61")
Table Height Centre Line (Vertical)	1295mm (51")
Degree of Tilting	135°
Table Rotation Speed	0.033 - 0.66rpm
Tilt Speed	150 secs for 135°
Control/Pendant	Tilt-Up/Tilt-Down/Forward/Stop/Reverse/Speed Control/Emergency Stop - 10m cable
Power Supply	380 / 480V - 3 Phase - 50/60Hz
Control Panel	AC Control 32Amp
Earthing	600Amp
Weight	6900kg (15,211lb)
Dimensions LxWxH (Table at lowest point)	L2840mm x W2250mm x H1550mm (L9.3' x W7.4' x H5.1')

Westermans International Ltd
Unit 4 Midland Distribution Centre,
Markfield Road, Groby
Leicestershire, LE6 0FS

www.westermans.com welding@westermans.com Tel:+44(0) 116 2696941



Westermans International Ltd
welding and cutting solutions that don't cost the earth

W: www.westermans.com E: welding@westermans.com
T: +44 (0)116 269 6941



VP10

Fixed Height Welding Positioner

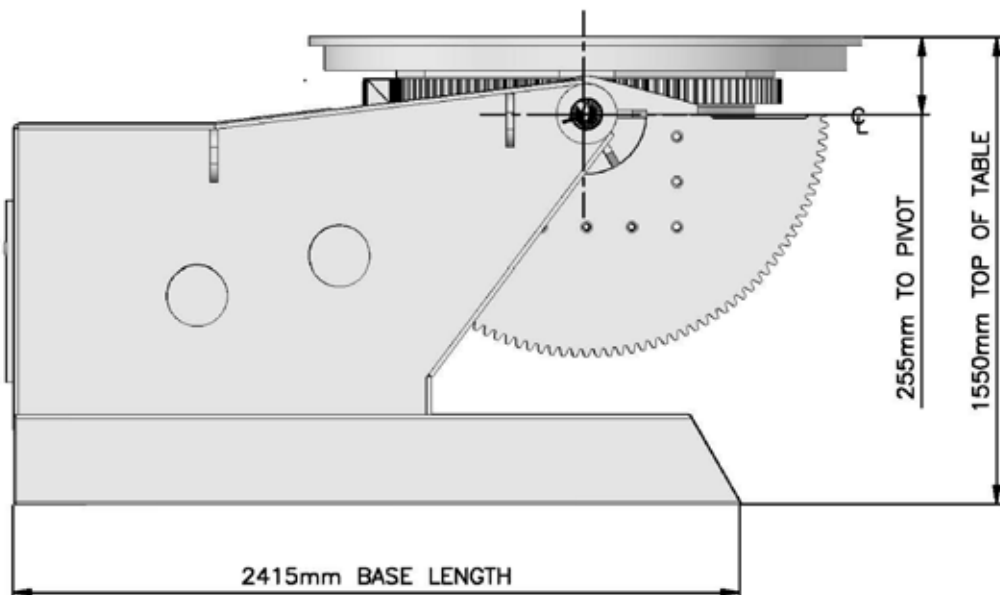
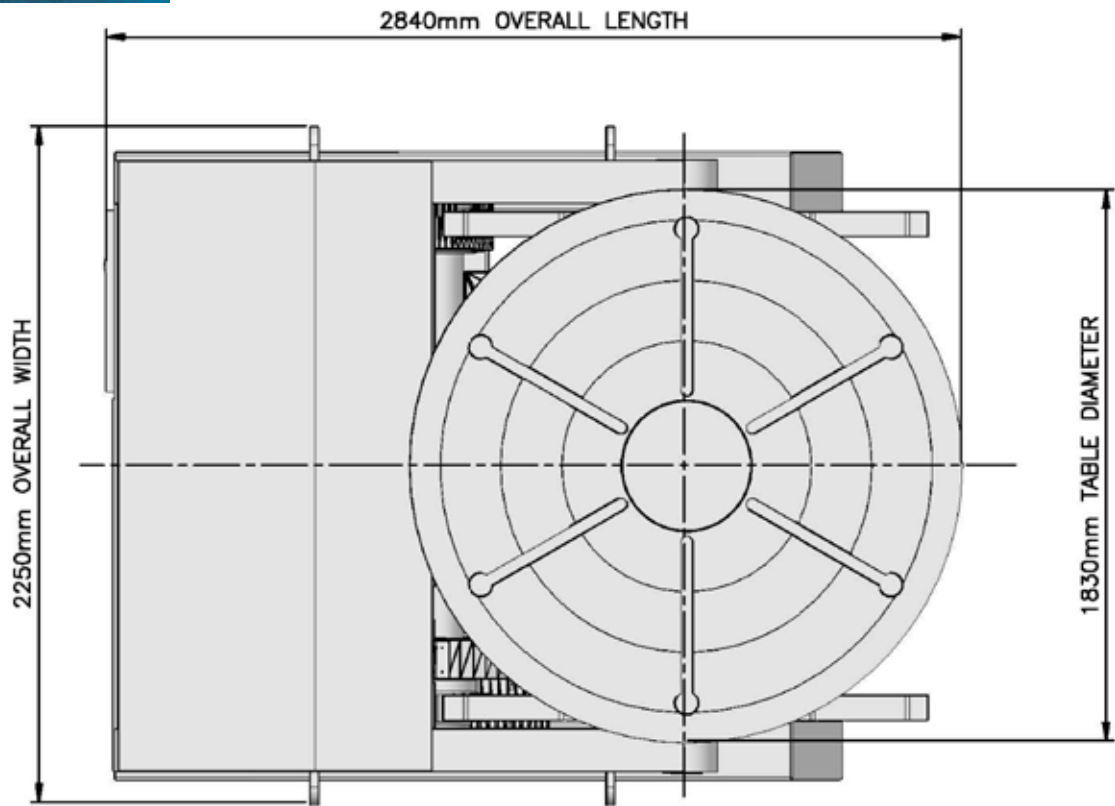

Westermans International Ltd
Unit 4 Midland Distribution Centre,
Markfield Road, Groby
Leicestershire, LE6 0FS

www.westermans.com welding@westermans.com Tel:+44(0) 116 2696941