



• U-Type torch stand



• Standard torch stand



• U-Type torch stand + TL-101

ServoArc welding system

PT-200s
Mini / Stable / Easy

PT-200s

ProArc has launched ServoArc mini positioner, precise and smart PT-200s, which is specially designed for users who want to employ automated welding. In addition, to provide the most stable rotation, PT-200s adopts a multi-functional CB-500 controller with user friendly and simple operation interface. It's easy to build your own welding parameter library that significantly improves welding quality and increases production yield in a short time.

Features

- Excellent graphic user interface controller
- Uses 20-bit servo motor to achieve 0.1° rotation accuracy
- Speed of 0.01 ~ 16 rpm with constant torque & rotation stability
- Tilting range from 0 ~ 120°, manual adjustment
- Floor type structure for convenient loading/unloading of weldments - create welding flexibility
- High frequency interference protection
- Spindle through hole allows delivery of shield gas



CB-500 controller

CB-500 is an easy and quick to get operated controller. The optimized graphical operation interface is easy to understand and can be used by any new operators and welding engineers.

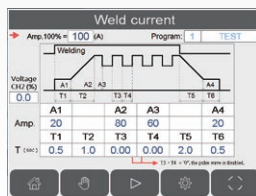
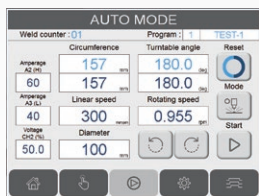

- GUI - simple and intuitive operation
- Automatic calculation of rotation speed and linear speed
- Welding sequence can be set to optimize welding quality
- Store 100 programs – including welding current, diameter, speed and sequence
- Programs can be edited
- Multilingual controller - English, Spanish, German, Russian, Japanese and Chinese languages

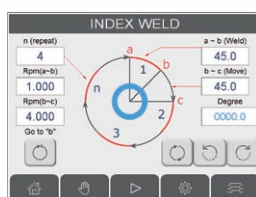
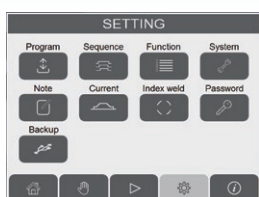

PT-200s

Torch stand

Standard torch stand

- TS-145

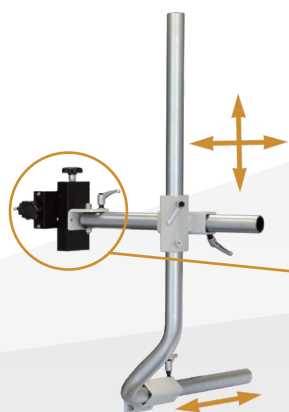

U-Type torch stand

- U-Type



Options

3-Jaw chucks



• PG-150

- PG-150, OD 4 ~ 150 mm
- PG-300, OD 4 ~ 300 mm

Weaving oscillator



• WO-15

Pneumatic torch lift



• TL-101, lift 30°

Safety viewer

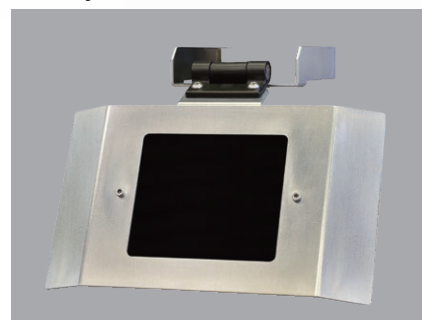

• SV-260

Pipe stand roll

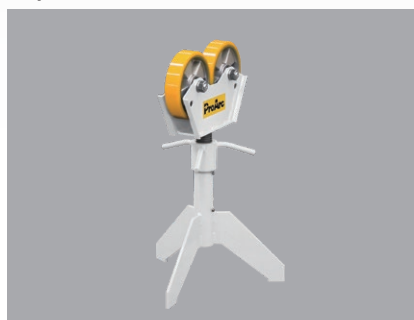

Specification

Model	Unit	PT-200s
Power input		1Ø 220VAC 50/60Hz
Capacity (Horizontal / Vertical) (W)	kg	200 / 130
Rated eccentricity (S)	mm	25
Rotation speed	rpm	0.01 ~ 16
Tilt range	deg	0 ~ 120°
Earthing	amp	300
Overall length (A)	mm	530
Overall width (B)	mm	315
Overall height (C)	mm	690
Center to floor (D)	mm	600
Table dimension (E)	mm	320
Through hole diameter	mm	Ø22
Table slot bolt size		M10
Weight	kg	45

※ Specifications subject to change without notice.

Dimensions

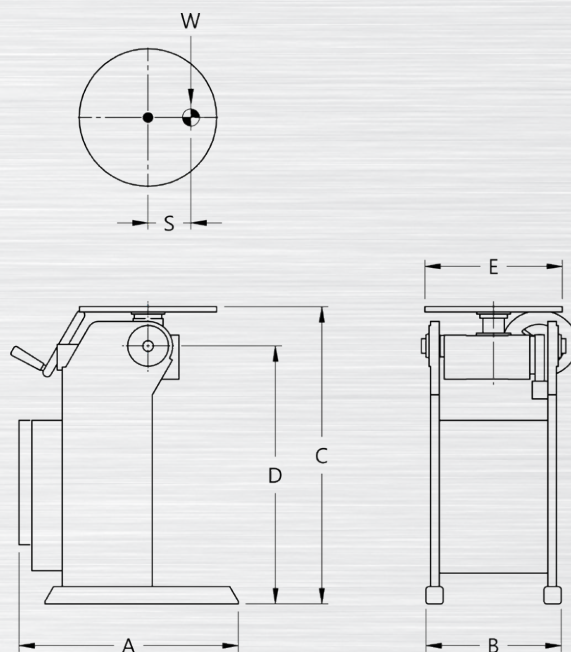

United ProArc Corporation

No.8 Gungye 2nd Road, Pingjen Industrial Park, Pingjen Dist., Taoyuan City 324403, Taiwan

Tel : 886-3-4696600 Fax : 886-3-4694499 E-mail : sales@proarc.com.tw