



# ***ESP-150***

## ***Plasma Cutting System***



### **Instruction Manual**

**This manual provides installation and operation instructions for the following components beginning with Serial Number PORJ129127:**

**BE SURE THIS INFORMATION REACHES THE OPERATOR.  
YOU CAN GET EXTRA COPIES THROUGH YOUR SUPPLIER.**

## **CAUTION**

**These INSTRUCTIONS are for experienced operators. If you are not fully familiar with the principles of operation and safe practices for arc welding and cutting equipment, we urge you to read our booklet, "Precautions and Safe Practices for Arc Welding, Cutting, and Gouging," Form 52-529. Do NOT permit untrained persons to install, operate, or maintain this equipment. Do NOT attempt to install or operate this equipment until you have read and fully understand these instructions. If you do not fully understand these instructions, contact your supplier for further information. Be sure to read the Safety Precautions before installing or operating this equipment.**

## **USER RESPONSIBILITY**

This equipment will perform in conformity with the description thereof contained in this manual and accompanying labels and/or inserts when installed, operated, maintained and repaired in accordance with the instructions provided. This equipment must be checked periodically. Malfunctioning or poorly maintained equipment should not be used. Parts that are broken, missing, worn, distorted or contaminated should be replaced immediately. Should such repair or replacement become necessary, the manufacturer recommends that a telephone or written request for service advice be made to the Authorized Distributor from whom it was purchased.

This equipment or any of its parts should not be altered without the prior written approval of the manufacturer. The user of this equipment shall have the sole responsibility for any malfunction which results from improper use, faulty maintenance, damage, improper repair or alteration by anyone other than the manufacturer or a service facility designated by the manufacturer.

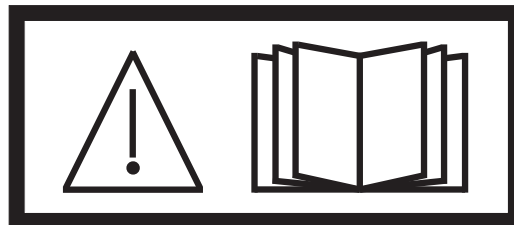

**READ AND UNDERSTAND THE INSTRUCTION MANUAL BEFORE INSTALLING OR OPERATING.**

**PROTECT YOURSELF AND OTHERS!**

---

# TABLE OF CONTENTS

---

| Section / Title                                | Page |
|--|------|
| 1.0 Safety Precautions .....                   | 5    |
| 1.1 Safety - English .....                     | 5    |
| 1.2 Safety - Spanish .....                     | 9    |
| 1.3 Safety - French .....                      | 13   |
| 2.0 Description .....                          | 17   |
| 2.1 Equipment .....                            | 17   |
| 3.0 Installation.....                          | 23   |
| 3.1 Inspection and Placement .....             | 23   |
| 3.2 Primary Input Electrical Connections ..... | 24   |
| 3.3 Voltage Divider Adjustment.....            | 28   |
| 3.4 Torch Connections.....                     | 29   |
| 3.5 Gas Supply Connections .....               | 30   |
| 3.6 Work and Earth Connections .....           | 31   |
| 3.7 Torch Coolant Preparation .....            | 31   |
| 4.0 Operation .....                            | 33   |
| 4.1 Controls and Indicators .....              | 33   |
| 4.2 ESP-150 Adjustments .....                  | 35   |
| 4.3 Operation .....                            | 35   |
| 4.4 Standoff and Cut Quality .....             | 37   |
| 4.5 Dross Formation .....                      | 38   |
| 4.6 Common Cutting Problems .....              | 39   |
| 4.7 Operating Parameters.....                  | 40   |
| 4.8 Cut Data.....                              | 40   |
| 5.0 Maintenance.....                           | 47   |
| 5.1 Troubleshooting.....                       | 49   |
| 6.0 Replacement Parts .....                    | 55   |
| 6.1 General .....                              | 55   |
| 6.2 Ordering .....                             | 55   |

---

## TABLE OF CONTENTS

---

## 1.0 Safety Precautions



**WARNING:** These Safety Precautions are for your protection. They summarize precautionary information from the references listed in Additional Safety Information section. Before performing any installation or operating procedures, be sure to read and follow the safety precautions listed below as well as all other manuals, material safety data sheets, labels, etc. Failure to observe Safety Precautions can result in injury or death.



**PROTECT YOURSELF AND OTHERS -- Some welding, cutting, and gouging processes are noisy and require ear protection. The arc, like the sun, emits ultraviolet (UV) and other radiation and can injure skin and eyes. Hot metal can cause burns. Training in the proper use of the processes and equipment is essential to prevent accidents. Therefore:**

1. Always wear safety glasses with side shields in any work area, even if welding helmets, face shields, and goggles are also required.
2. Use a face shield fitted with the correct filter and cover plates to protect your eyes, face, neck, and ears from sparks and rays of the arc when operating or observing operations. Warn bystanders not to watch the arc and not to expose themselves to the rays of the electric-arc or hot metal.
3. Wear flameproof gauntlet type gloves, heavy long-sleeve shirt, cuffless trousers, high-topped shoes, and a welding helmet or cap for hair protection, to protect against arc rays and hot sparks or hot metal. A flameproof apron may also be desirable as protection against radiated heat and sparks.
4. Hot sparks or metal can lodge in rolled up sleeves, trouser cuffs, or pockets. Sleeves and collars should be kept buttoned, and open pockets eliminated from the front of clothing.
5. Protect other personnel from arc rays and hot sparks with a suitable non-flammable partition or curtains.
6. Use goggles over safety glasses when chipping slag or grinding. Chipped slag may be hot and can fly far. Bystanders should also wear goggles over safety glasses.

## 1.1 Safety - English



**FIRES AND EXPLOSIONS -- Heat from flames and arcs can start fires. Hot slag or sparks can also cause fires and explosions. Therefore:**

1. Remove all combustible materials well away from the work area or cover the materials with a protective non-flammable covering. Combustible materials include wood, cloth, sawdust, liquid and gas fuels, solvents, paints and coatings, paper, etc.
2. Hot sparks or hot metal can fall through cracks or crevices in floors or wall openings and cause a hidden smoldering fire or fires on the floor below. Make certain that such openings are protected from hot sparks and metal."
3. Do not weld, cut or perform other hot work until the workpiece has been completely cleaned so that there are no substances on the workpiece which might produce flammable or toxic vapors. Do not do hot work on closed containers. They may explode.
4. Have fire extinguishing equipment handy for instant use, such as a garden hose, water pail, sand bucket, or portable fire extinguisher. Be sure you are trained in its use.
5. Do not use equipment beyond its ratings. For example, overloaded welding cable can overheat and create a fire hazard.
6. After completing operations, inspect the work area to make certain there are no hot sparks or hot metal which could cause a later fire. Use fire watchers when necessary.
7. For additional information, refer to NFPA Standard 51B, "Fire Prevention in Use of Cutting and Welding Processes"; available from the National Fire Protection Association, Batterymarch Park, Quincy, MA 02269.

**ELECTRICAL SHOCK -- Contact with live electrical parts and ground can cause severe injury or death. DO NOT use AC welding current in damp areas, if movement is confined, or if there is danger of falling.**



1. Be sure the power source frame (chassis) is connected to the ground system of the input power.
2. Connect the workpiece to a good electrical ground.
3. Connect the work cable to the workpiece. A poor or missing connection can expose you or others to a fatal shock.
4. Use well-maintained equipment. Replace worn or damaged cables.
5. Keep everything dry, including clothing, work area, cables, torch/electrode holder, and power source.
6. Make sure that all parts of your body are insulated from work and from ground.
7. Do not stand directly on metal or the earth while working in tight quarters or a damp area; stand on dry boards or an insulating platform and wear rubber-soled shoes.
8. Put on dry, hole-free gloves before turning on the power.
9. Turn off the power before removing your gloves.
10. Refer to ANSI/ASC Standard Z49.1 (listed on next page) for specific grounding recommendations. Do not mistake the work lead for a ground cable.

**ELECTRIC AND MAGNETIC FIELDS — May be dangerous. Electric current flowing through any conductor causes localized Electric and Magnetic Fields (EMF). Welding and cutting current creates EMF around welding cables and welding machines. Therefore:**



1. Welders having pacemakers should consult their physician before welding. EMF may interfere with some pacemakers.
2. Exposure to EMF may have other health effects which are unknown.

3. Welders should use the following procedures to minimize exposure to EMF:
  - A. Route the electrode and work cables together. Secure them with tape when possible.
  - B. Never coil the torch or work cable around your body.
  - C. Do not place your body between the torch and work cables. Route cables on the same side of your body.
  - D. Connect the work cable to the workpiece as close as possible to the area being welded.
  - E. Keep welding power source and cables as far away from your body as possible.



**FUMES AND GASES -- Fumes and gases, can cause discomfort or harm, particularly in confined spaces. Do not breathe fumes and gases. Shielding gases can cause asphyxiation.**

**Therefore:**

1. Always provide adequate ventilation in the work area by natural or mechanical means. Do not weld, cut, or gouge on materials such as galvanized steel, stainless steel, copper, zinc, lead, beryllium, or cadmium unless positive mechanical ventilation is provided. Do not breathe fumes from these materials.
2. Do not operate near degreasing and spraying operations. The heat or arc rays can react with chlorinated hydrocarbon vapors to form phosgene, a highly toxic gas, and other irritant gases.
3. If you develop momentary eye, nose, or throat irritation while operating, this is an indication that ventilation is not adequate. Stop work and take necessary steps to improve ventilation in the work area. Do not continue to operate if physical discomfort persists.
4. Refer to ANSI/ASC Standard Z49.1 (see listing below) for specific ventilation recommendations.

**5. WARNING:** This product, when used for welding or cutting, produces fumes or gases which contain chemicals known to the State of California to cause birth defects and, in some cases, cancer. (California Health & Safety Code §25249.5 et seq.)



**CYLINDER HANDLING -- Cylinders, if mishandled, can rupture and violently release gas. Sudden rupture of cylinder, valve, or relief device can injure or kill. Therefore:**

1. Use the proper gas for the process and use the proper pressure reducing regulator designed to operate from the compressed gas cylinder. Do not use adaptors. Maintain hoses and fittings in good condition. Follow manufacturer's operating instructions for mounting regulator to a compressed gas cylinder.
2. Always secure cylinders in an upright position by chain or strap to suitable hand trucks, undercarriages, benches, walls, post, or racks. Never secure cylinders to work tables or fixtures where they may become part of an electrical circuit.
3. When not in use, keep cylinder valves closed. Have valve protection cap in place if regulator is not connected. Secure and move cylinders by using suitable hand trucks. Avoid rough handling of cylinders.
4. Locate cylinders away from heat, sparks, and flames. Never strike an arc on a cylinder.
5. For additional information, refer to CGA Standard P-1, "Precautions for Safe Handling of Compressed Gases in Cylinders", which is available from Compressed Gas Association, 1235 Jefferson Davis Highway, Arlington, VA 22202.

**EQUIPMENT MAINTENANCE -- Faulty or improperly maintained equipment can cause injury or death. Therefore:**



1. Always have qualified personnel perform the installation, troubleshooting, and maintenance work. Do not perform any electrical work unless you are qualified to perform such work.
2. Before performing any maintenance work inside a power source, disconnect the power source from the incoming electrical power.
3. Maintain cables, grounding wire, connections, power cord, and power supply in safe working order. Do not operate any equipment in faulty condition.
4. Do not abuse any equipment or accessories. Keep equipment away from heat sources such as furnaces, wet conditions such as water puddles, oil or grease, corrosive atmospheres and inclement weather.
5. Keep all safety devices and cabinet covers in position and in good repair.
6. Use equipment only for its intended purpose. Do not modify it in any manner.



**ADDITIONAL SAFETY INFORMATION -- For more information on safe practices for electric arc welding and cutting equipment, ask your supplier for a copy of "Precautions and Safe Practices for Arc Welding, Cutting and Gouging", Form 52-529.**

The following publications, which are available from the American Welding Society, 550 N.W. LeJuene Road, Miami, FL 33126, are recommended to you:

1. ANSI/ASC Z49.1 - "Safety in Welding and Cutting"
2. AWS C5.1 - "Recommended Practices for Plasma Arc Welding"
3. AWS C5.2 - "Recommended Practices for Plasma Arc Cutting"
4. AWS C5.3 - "Recommended Practices for Air Carbon Arc Gouging and Cutting"

5. AWS C5.5 - "Recommended Practices for Gas Tungsten Arc Welding"
6. AWS C5.6 - "Recommended Practices for Gas Metal Arc Welding"
7. AWS SP - "Safe Practices" - Reprint, Welding Handbook.
8. ANSI/AWS F4.1, "Recommended Safe Practices for Welding and Cutting of Containers That Have Held Hazardous Substances."

**MEANING OF SYMBOLS - As used throughout this manual: Means Attention! Be Alert! Your safety is involved.**



**Means immediate hazards which, if not avoided, will result in immediate, serious personal injury or loss of life.**



**Means potential hazards which could result in personal injury or loss of life.**



**Means hazards which could result in minor personal injury.**



## 1.2 Safety - Spanish



**ADVERTENCIA:** Estas Precauciones de Seguridad son para su protección. Ellas hacen resumen de información proveniente de las referencias listadas en la sección "Información Adicional Sobre La Seguridad". Antes de hacer cualquier instalación o procedimiento de operación, asegúrese de leer y seguir las precauciones de seguridad listadas a continuación así como también todo manual, hoja de datos de seguridad del material, calcomanías, etc. El no observar las Precauciones de Seguridad puede resultar en daño a la persona o muerte.



**PROTEJASE USTED Y A LOS DEMÁS:** - Algunos procesos de soldadura, corte y ranurado son ruidosos y requieren protección para los oídos. El arco, como el sol, emite rayos ultravioleta (UV) y otras radiaciones que pueden dañar la piel y los ojos. El metal caliente causa quemaduras. EL entrenamiento en el uso propio de los equipos y sus procesos es esencial para prevenir accidentes. Por lo tanto:

1. Utilice gafas de seguridad con protección a los lados siempre que esté en el área de trabajo, aún cuando esté usando careta de soldar, protector para su cara u otro tipo de protección.
2. Use una careta que tenga el filtro correcto y lente para proteger sus ojos, cara, cuello, y oídos de las chispas y rayos del arco cuando se esté operando y observando las operaciones. Alerta a todas las personas cercanas de no mirar el arco y no exponerse a los rayos del arco eléctrico o el metal fundido.
3. Use guantes de cuero a prueba de fuego, camisa pesada de mangas largas, pantalón de ruedo liso, zapato alto al tobillo, y careta de soldar con capucha para el pelo, para proteger el cuerpo de los rayos y chispas calientes provenientes del metal fundido. En ocasiones un delantal a prueba de fuego es necesario para protegerse del calor radiado y las chispas.
4. Chispas y partículas de metal caliente puede alojarse en las mangas enrolladas de la camisa, el ruedo del pantalón o los bolsillos. Mangas y cuellos deberán mantenerse abotonados, bolsillos al frente de la camisa deberán ser cerrados o eliminados.
5. Proteja a otras personas de los rayos del arco y chispas calientes con una cortina adecuada no-flamable como división.
6. Use careta protectora además de sus gafas de seguridad cuando esté removiendo escoria o puliendo.

La escoria puede estar caliente y desprenderse con velocidad. Personas cercanas deberán usar gafas de seguridad y careta protectora.



**FUEGO Y EXPLOSIONES** -- El calor de las flamas y el arco pueden ocasionar fuegos. Escoria caliente y las chispas pueden causar fuegos y explosiones. Por lo tanto:

1. Remueva todo material combustible lejos del área de trabajo o cubra los materiales con una cobija a prueba de fuego. Materiales combustibles incluyen madera, ropa, líquidos y gases inflamables, solventes, pinturas, papel, etc.
2. Chispas y partículas de metal pueden introducirse en las grietas y agujeros de pisos y paredes causando fuegos escondidos en otros niveles o espacios. Asegúrese de que toda grieta y agujero esté cubierto para proteger lugares adyacentes contra fuegos.
3. No corte, suelde o haga cualquier otro trabajo relacionado hasta que la pieza de trabajo esté totalmente limpia y libre de sustancias que puedan producir gases inflamables o vapores tóxicos. No trabaje dentro o fuera de contenedores o tanques cerrados. Estos pueden explotar si contienen vapores inflamables.
4. Tenga siempre a la mano equipo extintor de fuego para uso instantáneo, como por ejemplo una manguera con agua, cubeta con agua, cubeta con arena, o extintor portátil. Asegúrese que usted esta entrenado para su uso.
5. No use el equipo fuera de su rango de operación. Por ejemplo, el calor causado por cable sobrecarga en los cables de soldar pueden ocasionar un fuego.
6. Después de terminar la operación del equipo, inspeccione el área de trabajo para cerciorarse de que las chispas o metal caliente ocasionen un fuego más tarde. Tenga personal asignado para vigilar si es necesario.
7. Para información adicional, haga referencia a la publicación NFPA Standard 51B, "Fire Prevention in Use of Cutting and Welding Processes", disponible a través de la National Fire Protection Association, Batterymarch Park, Quincy, MA 02269.



**CHOQUE ELECTRICO** -- El contacto con las partes eléctricas energizadas y tierra puede causar daño severo o muerte. NO use soldadura de corriente alterna (AC) en áreas húmedas, de movimiento confinado en lugares estrechos o si hay posibilidad de caer al suelo.

1. Asegúrese de que el chasis de la fuente de poder esté conectado a tierra a través del sistema de electricidad primario.
2. Conecte la pieza de trabajo a un buen sistema de tierra física.
3. Conecte el cable de retorno a la pieza de trabajo. Cables y conductores expuestos o con malas conexiones pueden exponer al operador u otras personas a un choque eléctrico fatal.
4. Use el equipo solamente si está en buenas condiciones. Reemplace cables rotos, dañados o con conductores expuestos.
5. Mantenga todo seco, incluyendo su ropa, el área de trabajo, los cables, antorchas, pinza del electrodo, y la fuente de poder.
6. Asegúrese que todas las partes de su cuerpo están insuladas de ambos, la pieza de trabajo y tierra.
7. No se pare directamente sobre metal o tierra mientras trabaja en lugares estrechos o áreas húmedas; trabaje sobre un pedazo de madera seco o una plataforma insulada y use zapatos con suela de goma.
8. Use guantes secos y sin agujeros antes de energizar el equipo.
9. Apague el equipo antes de quitarse sus guantes.
10. Use como referencia la publicación ANSI/ASC Standard Z49.1 (listado en la próxima página) para recomendaciones específicas de como conectar el equipo a tierra. No confunda el cable de soldar a la pieza de trabajo con el cable a tierra.



**CAMPOS ELECTRICOS Y MAGNETICOS - Son peligrosos. La corriente eléctrica fluye a través de cualquier conductor causando a nivel local Campos Eléctricos y Magnéticos (EMF). Las corrientes en el área de corte y soldadura, crean EMF alrededor de los cables de soldar y las maquinas.**  
**Por lo tanto:**

1. Soldadores u Operadores que use marca-pasos para el corazón deberán consultar a su médico antes de soldar. El Campo Electromagnético (EMF) puede interferir con algunos marca-pasos.
2. Exponerse a campos electromagnéticos (EMF) puede causar otros efectos de salud aún desconocidos.

3. Los soldadores deberán usar los siguientes procedimientos para minimizar exponerse al EMF:

- A. Mantenga el electrodo y el cable a la pieza de trabajo juntos, hasta llegar a la pieza que usted quiere soldar. Asegúrelos uno junto al otro con cinta adhesiva cuando sea posible.
- B. Nunca envuelva los cables de soldar alrededor de su cuerpo.
- C. Nunca ubique su cuerpo entre la antorcha y el cable, a la pieza de trabajo. Mantenga los cables a un sólo lado de su cuerpo.
- D. Conecte el cable de trabajo a la pieza de trabajo lo más cercano posible al área de la soldadura.
- E. Mantenga la fuente de poder y los cables de soldar lo más lejos posible de su cuerpo.



**HUMO Y GASES -- El humo y los gases, pueden causar malestar o daño, particularmente en espacios sin ventilación. No inhale el humo o gases. El gas de protección puede causar falta de oxígeno.**

**Por lo tanto:**

1. Siempre provea ventilación adecuada en el área de trabajo por medio natural o mecánico. No solde, corte, o ranure materiales con hierro galvanizado, acero inoxidable, cobre, zinc, plomo, berilio, o cadmio a menos que provea ventilación mecánica positiva. No respire los gases producidos por estos materiales.
2. No opere cerca de lugares donde se aplique sustancias químicas en aerosol. El calor de los rayos del arco pueden reaccionar con los vapores de hidrocarburo clorinado para formar un fosfógeno, o gas tóxico, y otros irritantes.
3. Si momentáneamente desarrolla irritación de ojos, nariz o garganta mientras está operando, es indicación de que la ventilación no es apropiada. Pare de trabajar y tome las medidas necesarias para mejorar la ventilación en el área de trabajo. No continúe operando si el malestar físico persiste.
4. Haga referencia a la publicación ANSI/ASC Standard Z49.1 (Vea la lista a continuación) para recomendaciones específicas en la ventilación.

- 5. ADVERTENCIA-- Este producto cuando se utiliza para soldaduras o cortes, produce humos o gases, los cuales contienen químicos conocidos por el Estado de California de causar defectos en el nacimiento, o en algunos casos, Cancer. (California Health & Safety Code §25249.5 et seq.)**

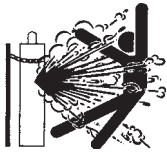

**MANEJO DE CILINDROS-- Los cilindros, si no son manejados correctamente, pueden romperse y liberar violentamente gases. Rotura repentina del cilindro, válvula, o válvula de escape puede causar daño o muerte. Por lo tanto:**

1. Utilice el gas apropiado para el proceso y utilice un regulador diseñado para operar y reducir la presión del cilindro de gas. No utilice adaptadores. Mantenga las mangueras y las conexiones en buenas condiciones. Observe las instrucciones de operación del fabricante para montar el regulador en el cilindro de gas comprimido.
2. Asegure siempre los cilindros en posición vertical y amárrelos con una correa o cadena adecuada para asegurar el cilindro al carro, transportes, tablleros, paredes, postes, o armazón. Nunca asegure los cilindros a la mesa de trabajo o las piezas que son parte del circuito de soldadura. Este puede ser parte del circuito eléctrico.
3. Cuando el cilindro no está en uso, mantenga la válvula del cilindro cerrada. Ponga el capote de protección sobre la válvula si el regulador no está conectado. Asegure y mueva los cilindros utilizando un carro o transporte adecuado. Evite el manejo brusco de los



**MANTENIMIENTO DEL EQUIPO -- Equipo defectuoso o mal mantenido puede causar daño o muerte. Por lo tanto:**

1. Siempre tenga personal cualificado para efectuar la instalación, diagnóstico, y mantenimiento del equipo. No ejecute ningún trabajo eléctrico a menos que usted esté cualificado para hacer el trabajo.
2. Antes de dar mantenimiento en el interior de la fuente de poder, desconecte la fuente de poder del suministro de electricidad primaria.
3. Mantenga los cables, cable a tierra, conexiones, cable primario, y cualquier otra fuente de poder en buen estado operacional. No opere ningún equipo en malas condiciones.
4. No abuse del equipo y sus accesorios. Mantenga el equipo lejos de cosas que generen calor como hornos, también lugares húmedos como charcos de agua, aceite o grasa, atmósferas corrosivas y las inclemencias del tiempo.
5. Mantenga todos los artículos de seguridad y coberturas del equipo en su posición y en buenas condiciones.
6. Use el equipo sólo para el propósito que fue diseñado. No modifique el equipo en ninguna manera.



**INFORMACION ADICIONAL DE SEGURIDAD -- Para más información sobre las prácticas de seguridad de los equipos de arco eléctrico para soldar y cortar, pregunte a su proveedor por una copia de "Precautions and Safe Practices for Arc Welding, Cutting and Gouging-Form 52-529."**

Las siguientes publicaciones, disponibles a través de la American Welding Society, 550 N.W. LeJuene Road, Miami, FL 33126, son recomendadas para usted:

1. ANSI/ASC Z49.1 - "Safety in Welding and Cutting"
2. AWS C5.1 - "Recommended Practices for Plasma Arc Welding"
3. AWS C5.2 - "Recommended Practices for Plasma Arc Cutting"
4. AWS C5.3 - "Recommended Practices for Air Carbon Arc Gouging and Cutting"



**SIGNIFICADO DE LOS SIMBOLOS**  
-- Según usted avanza en la lectura de este folleto: Los Símbolos Significan ¡Atención! ¡Esté Alerta! Se trata de su seguridad.



Significa riesgo inmediato que, de no ser evadido, puede resultar inmediatamente en serio daño personal o la muerte.



Significa el riesgo de un peligro potencial que puede resultar en serio daño personal o la muerte.



Significa el posible riesgo que puede resultar en menores daños a la persona.

## 1.3 Safety - French



**AVERTISSEMENT :** Ces règles de sécurité ont pour but d'assurer votre protection. Ils récapitulent les informations de précaution provenant des références dans la section des Informations de sécurité supplémentaires. Avant de procéder à l'installation ou d'utiliser l'unité, assurez-vous de lire et de suivre les précautions de sécurité ci-dessous, dans les manuels, les fiches d'information sur la sécurité du matériel et sur les étiquettes, etc. Tout défaut d'observer ces précautions de sécurité peut entraîner des blessures graves ou mortelles.



**PROTÉGEZ-VOUS** -- Les processus de soudage, de coupage et de gougeage produisent un niveau de bruit élevé et exige l'emploi d'une protection auditive. L'arc, tout comme le soleil, émet des rayons ultraviolets en plus d'autres rayons qui peuvent causer des blessures à la peau et les yeux. Le métal incandescent peut causer des brûlures. Une formation reliée à l'usage des processus et de l'équipement est essentielle pour prévenir les accidents. Par conséquent :

1. Portez des lunettes protectrices munies d'écrans latéraux lorsque vous êtes dans l'aire de travail, même si vous devez porter un casque de soudeur, un écran facial ou des lunettes étanches.
2. Portez un écran facial muni de verres filtrants et de plaques protectrices appropriées afin de protéger vos yeux, votre visage, votre cou et vos oreilles des étincelles et des rayons de l'arc lors d'une opération ou lorsque vous observez une opération. Avertissez les personnes se trouvant à proximité de ne pas regarder l'arc et de ne pas s'exposer aux rayons de l'arc électrique ou le métal incandescent.
3. Portez des gants ignifugés à crêpe, une chemise épaisse à manches longues, des pantalons sans rebord et des chaussures montantes afin de vous protéger des rayons de l'arc, des étincelles et du métal incandescent, en plus d'un casque de soudeur ou casquette pour protéger vos cheveux. Il est également recommandé de porter un tablier ininflammable afin de vous protéger des étincelles et de la chaleur par rayonnement.
4. Les étincelles et les projections de métal incandescent risquent de se loger dans les manches retroussées, les rebords de pantalons ou les poches. Il est recommandé de garder boutonnés le col et les manches et de porter des vêtements sans poches en avant.
5. Protégez toute personne se trouvant à proximité des étincelles et des rayons de l'arc à l'aide d'un rideau ou d'une cloison ininflammable.
6. Portez des lunettes étanches par dessus vos lunettes de sécurité lors des opérations d'écaillage ou de meulage du laitier. Les écailles de laitier incandescent peuvent être projetées à des distances considérables. Les personnes se trouvant à proximité doivent également porter des lunettes étanches par dessus leur lunettes de sécurité.



**INCENDIES ET EXPLOSIONS** -- La chaleur provenant des flammes ou de l'arc peut provoquer un incendie. Le laitier incandescent ou les étincelles peuvent également provoquer un incendie ou une explosion. Par conséquent :

1. Éloignez suffisamment tous les matériaux combustibles de l'aire de travail et recouvrez les matériaux avec un revêtement protecteur ininflammable. Les matériaux combustibles incluent le bois, les vêtements, la sciure, le gaz et les liquides combustibles, les solvants, les peintures et les revêtements, le papier, etc.
2. Les étincelles et les projections de métal incandescent peuvent tomber dans les fissures dans les planchers ou dans les ouvertures des murs et déclencher un incendie couvant à l'étage inférieur. Assurez-vous que ces ouvertures sont bien protégées des étincelles et du métal incandescent.
3. N'exécutez pas de soudure, de coupe ou autre travail à chaud avant d'avoir complètement nettoyé la surface de la pièce à traiter de façon à ce qu'il n'ait aucune substance présente qui pourrait produire des vapeurs inflammables ou toxiques. N'exécutez pas de travail à chaud sur des contenants fermés car ces derniers pourraient exploser.
4. Assurez-vous qu'un équipement d'extinction d'incendie est disponible et prêt à servir, tel qu'un tuyau d'arrosage, un seau d'eau, un seau de sable ou un extincteur portatif. Assurez-vous d'être bien instruit par rapport à l'usage de cet équipement.
5. Assurez-vous de ne pas excéder la capacité de l'équipement. Par exemple, un câble de soudage surchargé peut surchauffer et provoquer un incendie.
6. Une fois les opérations terminées, inspectez l'aire de travail pour assurer qu'aucune étincelle ou projection de métal incandescent ne risque de provoquer un incendie ultérieurement. Employez des guetteurs d'incendie au besoin.
7. Pour obtenir des informations supplémentaires, consultez le NFPA Standard 51B, "Fire Prevention in Use of Cutting and Welding Processes", disponible au National Fire Protection Association, Batterymarch Park, Quincy, MA 02269.



**CHOC ÉLECTRIQUE** -- Le contact avec des pièces électriques ou les pièces de mise à la terre sous tension peut causer des blessures graves ou mortelles. **NE PAS** utiliser un courant de soudage c.a. dans un endroit humide, en espace restreint ou si un danger de chute se pose.

1. Assurez-vous que le châssis de la source d'alimentation est branché au système de mise à la terre de l'alimentation d'entrée.
2. Branchez la pièce à traiter à une bonne mise de terre électrique.
3. Branchez le câble de masse à la pièce à traiter et assurez une bonne connexion afin d'éviter le risque de choc électrique mortel.
4. Utilisez toujours un équipement correctement entretenu. Remplacez les câbles usés ou endommagés.
5. Veillez à garder votre environnement sec, incluant les vêtements, l'aire de travail, les câbles, le porte-électrode/torche et la source d'alimentation.
6. Assurez-vous que tout votre corps est bien isolé de la pièce à traiter et des pièces de la mise à la terre.
7. Si vous devez effectuer votre travail dans un espace restreint ou humide, ne tenez vous pas directement sur le métal ou sur la terre; tenez-vous sur des planches sèches ou une plate-forme isolée et portez des chaussures à semelles de caoutchouc.
8. Avant de mettre l'équipement sous tension, isolez vos mains avec des gants secs et sans trous.
9. Mettez l'équipement hors tension avant d'enlever vos gants.
10. Consultez ANSI/ASC Standard Z49.1 (listé à la page suivante) pour des recommandations spécifiques concernant les procédures de mise à la terre. Ne pas confondre le câble de masse avec le câble de mise à la terre.



**CHAMPS ÉLECTRIQUES ET MAGNÉTIQUES — comportent un risque de danger. Le courant électrique qui passe dans n'importe quel conducteur produit des champs électriques et magnétiques localisés. Le soudage et le courant de coupage créent des champs électriques et magnétiques autour des câbles de soudage et l'équipement. Par conséquent :**

1. Un soudeur ayant un stimulateur cardiaque doit consulter son médecin avant d'entreprendre une opération de soudage. Les champs électriques et magnétiques peuvent causer des ennuis pour certains stimulateurs cardiaques.
2. L'exposition à des champs électriques et magnétiques peut avoir des effets néfastes inconnus pour la santé.

3. Les soudeurs doivent suivre les procédures suivantes pour minimiser l'exposition aux champs électriques et magnétiques :
  - A. Acheminez l'électrode et les câbles de masse ensemble. Fixez-les à l'aide d'une bande adhésive lorsque possible.
  - B. Ne jamais enrouler la torche ou le câble de masse autour de votre corps.
  - C. Ne jamais vous placer entre la torche et les câbles de masse. Acheminez tous les câbles sur le même côté de votre corps.
  - D. Branchez le câble de masse à la pièce à traiter le plus près possible de la section à souder.
  - E. Veillez à garder la source d'alimentation pour le soudage et les câbles à une distance appropriée de votre corps.



**LES VAPEURS ET LES GAZ -- peuvent causer un malaise ou des dommages corporels, plus particulièrement dans les espaces restreints. Ne respirez pas les vapeurs et les gaz. Le gaz de protection risque de causer l'asphyxie. Par conséquent :**

1. Assurez en permanence une ventilation adéquate dans l'aire de travail en maintenant une ventilation naturelle ou à l'aide de moyens mécanique. N'effectuez jamais de travaux de soudage, de coupage ou de gougeage sur des matériaux tels que l'acier galvanisé, l'acier inoxydable, le cuivre, le zinc, le plomb, le beryllium ou le cadmium en l'absence de moyens mécaniques de ventilation efficaces. Ne respirez pas les vapeurs de ces matériaux.
2. N'effectuez jamais de travaux à proximité d'une opération de dégraissage ou de pulvérisation. Lorsque la chaleur ou le rayonnement de l'arc entre en contact avec les vapeurs d'hydrocarbure chloré, ceci peut déclencher la formation de phosgène ou d'autres gaz irritants, tous extrêmement toxiques.
3. Une irritation momentanée des yeux, du nez ou de la gorge au cours d'une opération indique que la ventilation n'est pas adéquate. Cessez votre travail afin de prendre les mesures nécessaires pour améliorer la ventilation dans l'aire de travail. Ne poursuivez pas l'opération si le malaise persiste.
4. Consultez ANSI/ASC Standard Z49.1 (à la page suivante) pour des recommandations spécifiques concernant la ventilation.

**5. AVERTISSEMENT :** Ce produit, lorsqu'il est utilisé dans une opération de soudage ou de coupage, dégage des vapeurs ou des gaz contenant des chimiques considérés par l'état de la Californie comme étant une cause des malformations congénitales et dans certains cas, du cancer. (California Health & Safety Code §25249.5 et seq.)

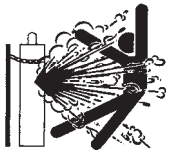

**MANIPULATION DES CYLINDRES**  
-- La manipulation d'un cylindre, sans observer les précautions nécessaires, peut produire des fissures et un échappement dangereux des gaz. Une brisure soudaine du cylindre, de la soupape ou du dispositif de surpression

peut causer des blessures graves ou mortelles. Par conséquent :

1. Utilisez toujours le gaz prévu pour une opération et le détendeur approprié conçu pour utilisation sur les cylindres de gaz comprimé. N'utilisez jamais d'adaptateur. Maintenez en bon état les tuyaux et les raccords. Observez les instructions d'opération du fabricant pour assembler le détendeur sur un cylindre de gaz comprimé.
2. Fixez les cylindres dans une position verticale, à l'aide d'une chaîne ou une sangle, sur un chariot manuel, un châssis de roulement, un banc, un mur, une colonne ou un support convenable. Ne fixez jamais un cylindre à un poste de travail ou toute autre dispositif faisant partie d'un circuit électrique.
3. Lorsque les cylindres ne servent pas, gardez les soupapes fermées. Si le détendeur n'est pas branché, assurez-vous que le bouchon de protection de la soupape est bien en place. Fixez et déplacez les cylindres à l'aide d'un chariot manuel approprié. Toujours manipuler les cylindres avec soin.
4. Placez les cylindres à une distance appropriée de toute source de chaleur, des étincelles et des flammes. Ne jamais amorcer l'arc sur un cylindre.
5. Pour de l'information supplémentaire, consultez CGA Standard P-1, "Precautions for Safe Handling of Compressed Gases in Cylinders", mis à votre disposition par le Compressed Gas Association, 1235 Jefferson Davis Highway, Arlington, VA 22202.



**ENTRETIEN DE L'ÉQUIPEMENT** -- Un équipement entretenu de façon défectueuse ou inadéquate peut causer des blessures graves ou mortelles. Par conséquent :

1. Efforcez-vous de toujours confier les tâches d'installation, de dépannage et d'entretien à un personnel qualifié. N'effectuez aucune réparation électrique à moins d'être qualifié à cet effet.
2. Avant de procéder à une tâche d'entretien à l'intérieur de la source d'alimentation, débranchez l'alimentation électrique.
3. Maintenez les câbles, les fils de mise à la terre, les branchements, le cordon d'alimentation et la source d'alimentation en bon état. N'utilisez jamais un équipement s'il présente une défektivité quelconque.
4. N'utilisez pas l'équipement de façon abusive. Gardez l'équipement à l'écart de toute source de chaleur, notamment des fours, de l'humidité, des flaques d'eau, de l'huile ou de la graisse, des atmosphères corrosives et des intempéries.
5. Laissez en place tous les dispositifs de sécurité et tous les panneaux de la console et maintenez-les en bon état.
6. Utilisez l'équipement conformément à son usage prévu et n'effectuez aucune modification.



**INFORMATIONS SUPPLÉMENTAIRES RELATIVES À LA SÉCURITÉ** -- Pour obtenir de l'information supplémentaire sur les règles de sécurité à observer pour l'équipement de soudage à l'arc électrique et le coupage, demandez un exemplaire du livret "Precautions and Safe Practices for Arc Welding, Cutting and Gouging", Form 52-529.

Les publications suivantes sont également recommandées et mises à votre disposition par l'American Welding Society, 550 N.W. LeJuene Road, Miami, FL 33126 :

1. ANSI/ASC Z49.1 - "Safety in Welding and Cutting"
2. AWS C5.1 - "Recommended Practices for Plasma Arc Welding"
3. AWS C5.2 - "Recommended Practices for Plasma Arc Cutting"
4. AWS C5.3 - "Recommended Practices for Air Carbon Arc Gouging and Cutting"

**SIGNIFICATION DES SYMBOLES**

Ce symbole, utilisé partout dans ce manuel, signifie "Attention"! Soyez vigilant! Votre sécurité est en jeu.

**DANGER**

Signifie un danger immédiat. La situation peut entraîner des blessures graves ou mortelles.

**AVERTISSEMENT**

Signifie un danger potentiel qui peut entraîner des blessures graves ou mortelles.

**ATTENTION**

Signifie un danger qui peut entraîner des blessures corporelles mineures.

**CAUTION**

Class A equipment is not intended for use in residential locations where the electrical power is provided by the public low-voltage supply system. There may be potential difficulties in ensuring electromagnetic compatibility of class A equipment in those locations, due to conducted as well as radiated disturbances.

**CAUTION**

This product is solely intended for plasma cutting.

**CAUTION**

Do not dispose of electrical equipment together with normal waste! In observance of European Directive 2002/96/EC on Waste Electrical and Electronic Equipment and its implementation in accordance with national law, electrical equipment that has reached the end of its life must be collected separately and returned to an environmentally compatible recycling facility. As the owner of the equipment, you should get information on approved collection systems from our local representative. By applying this European Directive you will improve the environment and human health!



## 2.0 Description

### ESP-150 Plasmarc™ System

This versatile, all encompassed heavy duty water cooled plasma cutting and gouging system is ideal for manual and mechanized applications.

- Greater productivity - high speed cutting of most metals from gauge thickness to 2" (50 mm) thick plate
- Versatility - 230/460/575 volt three-phase input
- Greater variation - adjustable output - 25 to 150 amps
- Built-In Water Cooler - simplifies maintenance, less hook-up, no wiring issues, no extra hoses. Water flow is controlled with power supply
- Water cooled Torch PT-26
- Leather sheath wrapped torch - protects torch leads from abrasion and molten metal
- Cuts with air, nitrogen, argon-hydrogen mixtures or nitrogen-hydrogen mixtures
- Built-In CNC interface provides easy connection of automation applications
- Torch design provides perfect electrode centering - provides longer tip life by minimizing the possibility of double-arcing
- Torch spare parts kit supplied with each outfit - ample supply of spare parts to minimize downtime at no additional cost
- Thermal overload switches - prevents damage if unit overheats due to insufficient air flow
- Line voltage compensation
- Automatic intermittent cutting - additional capability, permits continuous cutting of grates, expanded metal, heavy screen material, etc.
- Wheels and cylinder rack - all provided standard for portability and greater utilization at no additional cost
- Ideal for plasma gouging
- Three year warranty on console
- One Year warranty on torch

## 2.1 Equipment

The power source is supplied with coolant and instruction manual.

**3**  
YEAR  
WARRANTY



### Torch

PT-26 - 70°, 90° or In-Line

### Specifications

|   |  |
|---|--|
| Input Current and Input Voltage at Rated Load | 112/56/45 amps, 230/460/575 Vac, 60 Hz, 3 Ph |
| Output Rating                                 |  |
| 90% duty cycle                                | 150 amps @ 120 V                             |
| 100% duty cycle                               | 140 amps @ 120 V                             |
| Open circuit Voltage                          | 370 vdc                                      |
| Dimensions                                    |  |
| w   | 21.75 in. (552mm)                            |
| h   | 31.5 in. (800mm)                             |
| d   | 40 in. (1016mm)                              |
| Weight  | 766 lbs. (348 kg)                            |

### Duty cycle

The duty cycle refers to the time as a percentage of a ten-minute period that you can weld at a certain load without overloading. The duty cycle is valid for 40°C.

### Enclosure class

The IP code indicates the enclosure class, i. e. the degree of protection against penetration by solid objects or water.

**How to Order**

The ESP-150 package includes console, PT-26 torch with leather sheath, torch spare parts kit, 25 ft. or 50 ft. work cable, TR-21 truck with dual cylinder rack, regulators and gas hoses and torch coolant.

ESAB can provide you with all necessary welding protection and accessories.

**Ordering Information**

**ESP-150 Packages**

**230/460/575 V, 60Hz, 3 Phase**

|   |            |
|---|------------|
| ESP-150, 25' PT-26 70° Air .....                      | 0558002909 |
| ESP-150, 50' PT-26 70° Air .....                      | 0558002910 |
| ESP-150, 25' PT-26 90° Air .....                      | 0558002911 |
| ESP-150, 50' PT-26 90° Air .....                      | 0558002912 |
| ESP-150, 25' PT-26 Inline/Air .....                   | 0558002913 |
| ESP-150, 50' PT-26 Inline/Air .....                   | 0558002914 |
| ESP-150, 25' PT-26 70° Ar+H <sub>2</sub> Mix .....    | 0558002915 |
| ESP-150, 50' PT-26 70° Ar+H <sub>2</sub> Mix .....    | 0558002916 |
| ESP-150, 25' PT-26 90° Ar+H <sub>2</sub> Mix .....    | 0558002917 |
| ESP-150, 50' PT-26 90° Ar+H <sub>2</sub> Mix .....    | 0558002918 |
| ESP-150, 25' PT-26 Inline/Ar+H <sub>2</sub> Mix ..... | 0558002919 |
| ESP-150, 50' PT-26 Inline/Ar+H <sub>2</sub> Mix ..... | 0558002920 |

**ESP-150 Console Only**

|                                    |            |
|------------------------------------|------------|
| 230/460/575V, 60 Hz, 3 Phase ..... | 0558002677 |
|------------------------------------|------------|

**NOTE: Contact your ESAB Representative to substitute console.**

**Optional Accessories**

|   |            |
|---|------------|
| <b>150 amp Spare Parts Kit</b> .....  | 0558002864 |
| <b>Remote Hand Switch</b><br>Permits remote starting and stopping of cutting process;<br>used primarily for mechanized cutting.....                     | 2075600    |
| <b>25 ft. Leather Sheath*</b><br>Protects torch leads from abrasion and molten metal; particularly ....<br>recommended for plasma gouging .....         | 0558002921 |
| <b>50 ft. Leather Sheath*</b> .....   | 0558002922 |
| <b>Plasma Flow Measuring Kit</b><br>This valuable troubleshooting tool allows measurement of the .....<br>actual plasma gas flow through the torch..... | 19765      |
| <b>Plasma Torch Head Protector</b><br>For gouging .....   | 20806      |
| <b>Trigger Latch Kit</b><br>(Factory Installed Only).....   | 0588000939 |

\*Standard on manual torches.

**Assembly of PT-26 Front End Parts**

**PT-26 Manual Models**

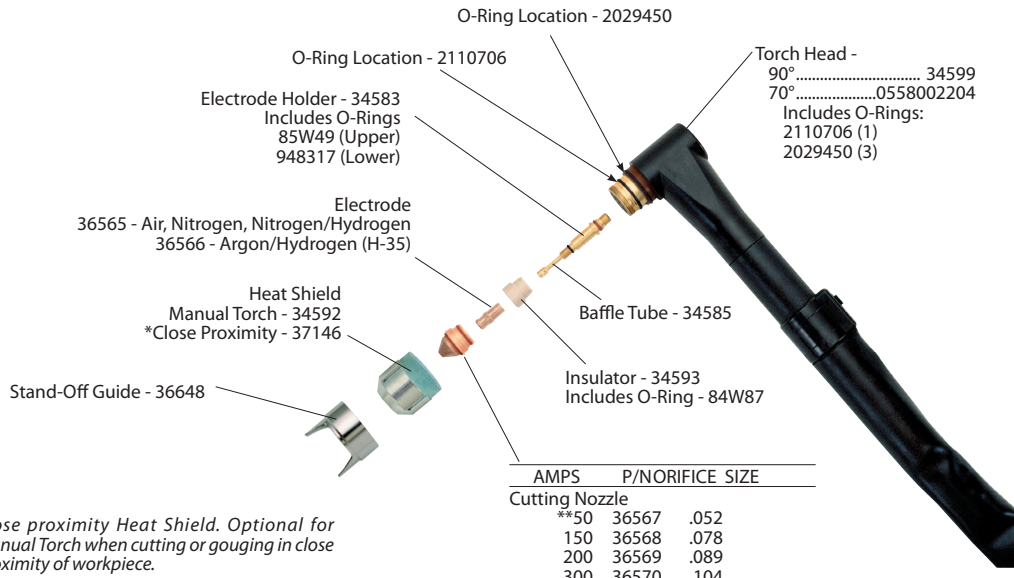

| AMPS                  | P/NORIFICE | SIZE |
|-----------------------|------------|------|
| <b>Cutting Nozzle</b> |            |      |
| **50                  | 36567      | .052 |
| 150                   | 36568      | .078 |
| 200                   | 36569      | .089 |
| 300                   | 36570      | .104 |
| <b>Gouging Nozzle</b> |            |      |
| 200                   | 36571      | .125 |
| 300                   | 36572      | .144 |

\* Close proximity Heat Shield. Optional for Manual Torch when cutting or gouging in close proximity of workpiece.

\*\*For 65 Amp Mechanized Cutting use Heat Shield 34592 or 37146

All include O-Rings 2110578 (Upper)  
994092 (Lower)

**PT-26 In-Line Models**

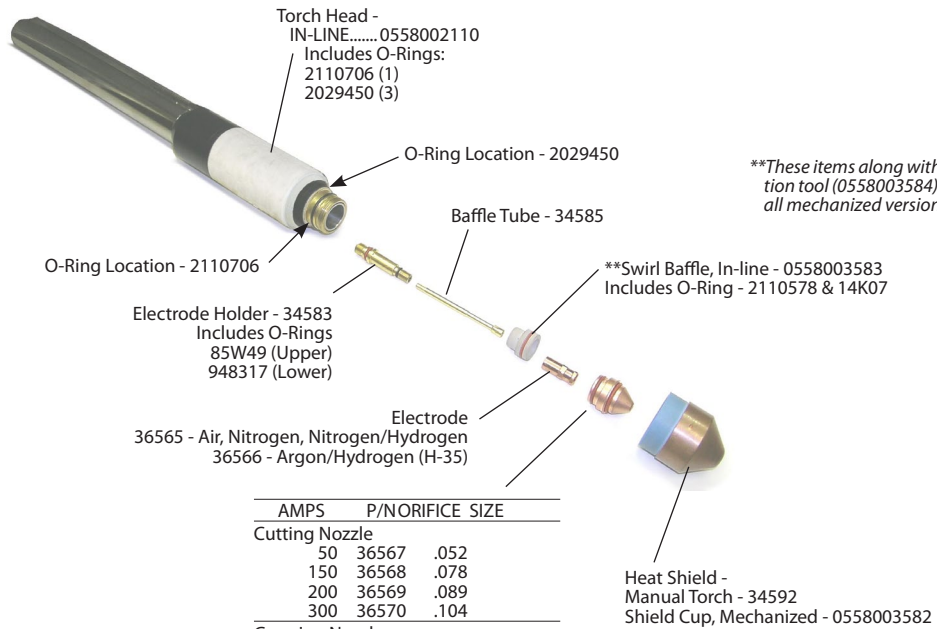

\*\*These items along with a baffle installation tool (0558003584) are shipped with all mechanized versions of this torch.

| AMPS                  | P/NORIFICE | SIZE |
|-----------------------|------------|------|
| <b>Cutting Nozzle</b> |            |      |
| 50                    | 36567      | .052 |
| 150                   | 36568      | .078 |
| 200                   | 36569      | .089 |
| 300                   | 36570      | .104 |
| <b>Gouging Nozzle</b> |            |      |
| 200                   | 36571      | .125 |
| 300                   | 36572      | .144 |

All include O-Rings 2110578 (Upper)  
994092 (Lower)

## SECTION 2

## DESCRIPTION

| PT-26 Technical Specifications (Plasma Gas)                   |  |                |        |
|---|--|----------------|--------|
| Type of Gas   | N <sub>2</sub> , Air, AR-H <sub>2</sub> , N <sub>2</sub> -H <sub>2</sub>       |                |        |
| Pressure  | 100 psig (6.9 bar)   |                |        |
| Flow  | 240 cfh (6.8 M <sup>3</sup> /h)  |                |        |
| Purity Required   | O <sub>2</sub> - 99.5% min., N <sub>2</sub> -99.995% min., Air - clean and dry |                |        |
| Recommended Liquid Cylinder Service Regulators                | Inert Gas  | R-76-150-580LC | 19977  |
| Recommended cylinder 2-Stage Regulators                       | Argon-Hydrogen   | R-77-75-350    | 998341 |
|   | Nitrogen   | R-77-75-580    | 998343 |
|   | Industrial Air   | R-77-150-590   | 998348 |
| Recommended Heavy-Duty Hi-Flow Station or Pipeline Regulators | Nitrogen   | R-76-75-034    | 19155  |

| PT-26 Technical Specifications (Starting Gas/Cutting Gas) |   |
|---|---|
| Type  | N <sub>2</sub> , Air (for Ar-H <sub>2</sub> Cut Gas Use N <sub>2</sub> or Ar-H <sub>2</sub> ) |
| Pressure  | 100 psig (6.9 bar)  |
| Flow  | 200 cfh (5.66M <sup>3</sup> /h) @ 60 psig (4.1 bar)   |
| Purity Required   | N <sub>2</sub> - 99% min., Air - clean and dry  |

| PT-26 Technical Specifications (Shield Gas) |   |
|---|---|
| Type  | N <sub>2</sub> or Air                                 |
| Pressure                                    | 100 psig (6.9 bar) maximum                            |
| Flow  | 200 cfh (5.66 M <sup>3</sup> /h) @ 85 psig (5.86 bar) |
| Purity Required                             | Nitrogen - 99% minimum, Air - clean and dry           |

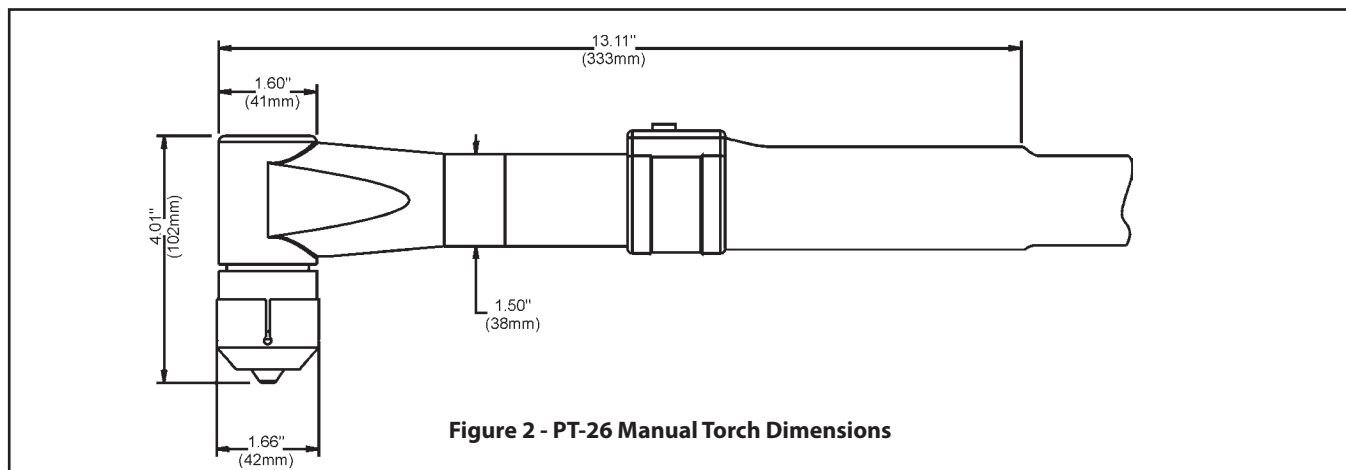
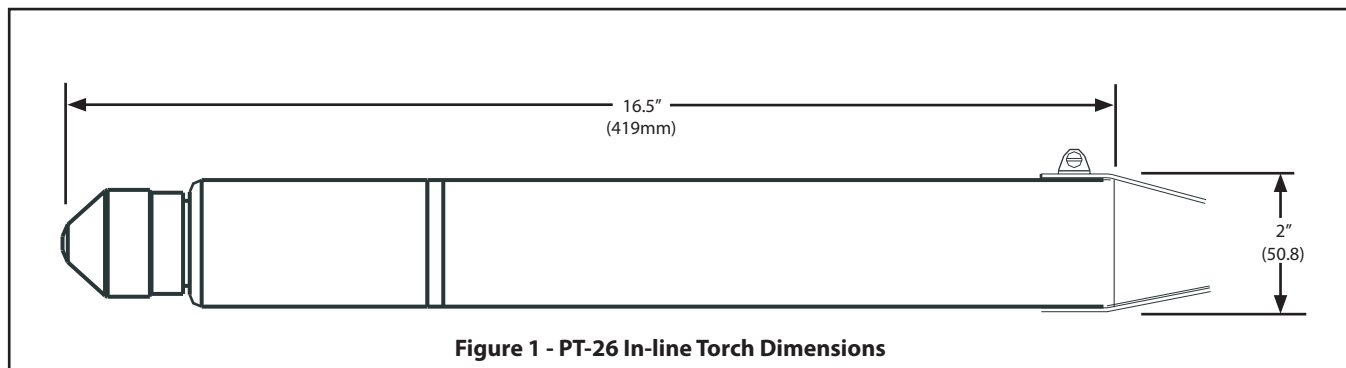

## SECTION 2

## DESCRIPTION

The ESP-150 system is available as pre-engineered basic packages or can be ordered as individual parts and pieces for a custom system. The basic pre-engineered systems contain the ESP-150 console, plasma torch, appropriate regulators for the gases indicated, and torch coolant. For torch information, refer to the PT-26 manual F-15-345.

### ESP-150 MANUAL PLASMA CUTTING PACKAGES

#### AIR PACKAGES

| 0558002909 - ESP-150 / PT-26 25' 70° / Air |     |                              |
|--|-----|------------------------------|
| P/N  | QTY | DESCRIPTION                  |
| 0558002677                                 | 1   | ESP-150 Console              |
| 0558002208                                 | 1   | PT-26, 70°, 25' Plasma Torch |
| 0558002864                                 | 1   | PT-26 Spare Parts Kit, 150A  |
| 0558003242                                 | 1   | Air Reg. Assembly            |
| 678724                                     | 1   | Work Cable, 50'              |
| 156F05                                     | 4   | Coolant (4 gallons)          |
| 680794                                     | 1   | Truck & Cylinder Rack        |

| 0558002910 - ESP-150 / PT-26 50' 70° / Air |     |                              |
|--|-----|------------------------------|
| P/N  | QTY | DESCRIPTION                  |
| 0558002677                                 | 1   | ESP-150 Console              |
| 0558002209                                 | 1   | PT-26, 70°, 50' Plasma Torch |
| 0558002864                                 | 1   | PT-26 Spare Parts Kit, 150A  |
| 0558003242                                 | 3   | Air Reg. Assembly            |
| 678724                                     | 1   | Work Cable, 50'              |
| 74576                                      | 3   | Adaptors                     |
| 19416                                      | 3   | Gas Hose                     |
| 36933GY                                    | 1   | Reg. Mount                   |
| 156F05                                     | 4   | Coolant (4 gallons)          |
| 680794                                     | 1   | Truck & Cylinder Rack        |

| 0558002911 - ESP-150 / PT-26 25' 90° / Air |     |                              |
|--|-----|------------------------------|
| P/N  | QTY | DESCRIPTION                  |
| 0558002677                                 | 1   | ESP-150 Console              |
| 36558                                      | 1   | PT-26, 90°, 25' Plasma Torch |
| 0558002864                                 | 1   | PT-26 Spare Parts Kit, 150A  |
| 0558003242                                 | 3   | Air Reg. Assembly            |
| 678723                                     | 1   | Work Cable, 25'              |
| 156F05                                     | 4   | Coolant (4 gallons)          |
| 680794                                     | 1   | Truck & Cylinder Rack        |

| 0558002912 - ESP-150 / PT-26 50' 90° / Air |     |                              |
|--|-----|------------------------------|
| P/N  | QTY | DESCRIPTION                  |
| 0558002677                                 | 1   | ESP-150 Console              |
| 36559                                      | 1   | PT-26, 90°, 50' Plasma Torch |
| 0558002864                                 | 1   | PT-26 Spare Parts Kit, 150A  |
| 0558003242                                 | 3   | Air Reg. Assembly            |
| 678724                                     | 1   | Work Cable, 50'              |
| 156F05                                     | 4   | Coolant (4 gallons)          |
| 680794                                     | 1   | Truck & Cylinder Rack        |

### Ar/H<sub>2</sub> PACKAGES

| 0558002915 - ESP-150 / PT-26 25' 70° / Ar+H2 Mix |     |                              |
|--|-----|------------------------------|
| P/N  | QTY | DESCRIPTION                  |
| 0558002677                                       | 1   | ESP-150 Console              |
| 0558002208                                       | 1   | PT-26, 70°, 25' Plasma Torch |
| 0558002864                                       | 1   | PT-26 Spare Parts Kit, 150A  |
| 998341   | 2   | Argon/Hydrogen Mix Regulator |
| 998343   | 1   | Nitrogen Regulator           |
| 33122  | 3   | Hoses                        |
| 678723   | 1   | Work Cable, 25'              |
| 19X54  | 2   | Adaptors                     |
| 156F05   | 4   | Coolant (4 gallons)          |
| 680794   | 1   | Truck & Cylinder Rack        |

| 0558002916 - ESP-150 / PT-26 50' 70° / Ar+H2 Mix |     |                              |
|--|-----|------------------------------|
| P/N  | QTY | DESCRIPTION                  |
| 0558002677                                       | 1   | ESP-150 Console              |
| 0558002209                                       | 1   | PT-26, 70°, 50' Plasma Torch |
| 0558002864                                       | 1   | PT-26 Spare Parts Kit, 150A  |
| 998341   | 2   | Argon/Hydrogen Mix Regulator |
| 998343   | 1   | Nitrogen Regulator           |
| 33122  | 3   | Hoses                        |
| 678724   | 1   | Work Cable, 50'              |
| 19X54  | 2   | Adaptors                     |
| 156F05   | 4   | Coolant (4 gallons)          |
| 680794   | 1   | Truck & Cylinder Rack        |

| 0558002917 - ESP-150 / PT-26 25' 90° / Ar+H2 Mix |     |                              |
|--|-----|------------------------------|
| P/N  | QTY | DESCRIPTION                  |
| 0558002677                                       | 1   | ESP-150 Console              |
| 36558  | 1   | PT-26, 90°, 25' Plasma Torch |
| 0558002864                                       | 1   | PT-26 Spare Parts Kit, 150A  |
| 998341   | 2   | Argon/Hydrogen Mix Regulator |
| 998343   | 1   | Nitrogen Regulator           |
| 33122  | 3   | Hoses                        |
| 678723   | 1   | Work Cable, 25'              |
| 19X54  | 2   | Adaptors                     |
| 156F05   | 4   | Coolant (4 gallons)          |
| 680794   | 1   | Truck & Cylinder Rack        |

| 0558002918 - ESP-150 / PT-26 50' 90° / Ar+H2 Mix |     |                              |
|--|-----|------------------------------|
| P/N  | QTY | DESCRIPTION                  |
| 0558002677                                       | 1   | ESP-150 Console              |
| 36559  | 1   | PT-26, 90°, 50' Plasma Torch |
| 0558002864                                       | 1   | PT-26 Spare Parts Kit, 150A  |
| 998341   | 2   | Argon/Hydrogen Mix Regulator |
| 998343   | 1   | Nitrogen Regulator           |
| 33122  | 3   | Hoses                        |
| 678724   | 1   | Work Cable, 50'              |
| 19X54  | 2   | Adaptors                     |
| 156F05   | 4   | Coolant (4 gallons)          |
| 680794   | 1   | Truck & Cylinder Rack        |

**SECTION 2****DESCRIPTION****ESP-150 MECHANIZED PLASMA CUTTING PACKAGES****AIR PACKAGES**

| 0558002913 - ESP-150 / PT-26 25' Inline / Air |     |                                |
|---|-----|--------------------------------|
| P/N   | QTY | DESCRIPTION                    |
| 0558002677                                    | 1   | ESP-150 Console                |
| 0558002320                                    | 1   | PT-26, 25' Inline Plasma Torch |
| 0558002864                                    | 1   | PT-26 Spare Parts Kit, 150A    |
| 0558003242                                    | 3   | Air Reg. Assembly              |
| 678723  | 1   | Work Cable, 25'                |
| 33053   | 1   | Strain Relief                  |
| 951188  | 1   | Locknut                        |
| 156F05  | 4   | Coolant (4 gallons)            |
| 680794  | 1   | Truck & Cylinder Rack          |

| 0558002914 - ESP-150 / PT-26 50' Inline / Air |     |                                |
|---|-----|--------------------------------|
| P/N   | QTY | DESCRIPTION                    |
| 0558002677                                    | 1   | ESP-150 Console                |
| 0558002321                                    | 1   | PT-26, 50' Inline Plasma Torch |
| 0558002864                                    | 1   | PT-26 Spare Parts Kit, 150A    |
| 0558003242                                    | 3   | Air Reg. Assembly              |
| 678724  | 1   | Work Cable, 50'                |
| 33053   | 1   | Strain Relief                  |
| 951188  | 1   | Locknut                        |
| 156F05  | 4   | Coolant (4 gallons)            |
| 680794  | 1   | Truck & Cylinder Rack          |

**Ar/H<sub>2</sub> PACKAGES**

| 0558002919 - ESP-150 / PT-26 25' Inline / Ar+H2 Mix |     |                                |
|---|-----|--------------------------------|
| P/N   | QTY | DESCRIPTION                    |
| 0558002677  | 1   | ESP-150 Console                |
| 0558002320  | 1   | PT-26, 25' Inline Plasma Torch |
| 0558002864  | 1   | PT-26 Spare Parts Kit, 150A    |
| 998341  | 2   | Argon/Hydrogen Mix Regulator   |
| 998343  | 1   | Nitrogen Regulator             |
| 33122   | 3   | Hoses                          |
| 678723  | 1   | Work Cable, 25'                |
| 33053   | 1   | Strain Relief                  |
| 951188  | 1   | Locknut                        |
| 19X54   | 2   | Adaptors                       |
| 156F05  | 4   | Coolant (4 gallons)            |
| 680794  | 1   | Truck & Cylinder Rack          |

| 0558002920 - ESP-150 / PT-26-50' Inline / Ar+H2 Mix |     |                                |
|---|-----|--------------------------------|
| P/N   | QTY | DESCRIPTION                    |
| 0558002677  | 1   | ESP-150 Console                |
| 0558002321  | 1   | PT-26, 50' Inline Plasma Torch |
| 0558002864  | 1   | PT-26 Spare Parts Kit, 150A    |
| 998341  | 2   | Argon/Hydrogen Mix Regulator   |
| 998343  | 1   | Nitrogen Regulator             |
| 33122   | 3   | Hoses                          |
| 678724  | 1   | Work Cable, 50'                |
| 33053   | 1   | Strain Relief                  |
| 951188  | 1   | Locknut                        |
| 19X54   | 2   | Adaptors                       |
| 156F05  | 4   | Coolant (4 gallons)            |
| 680794  | 1   | Truck & Cylinder Rack          |

**CAUTION**

**This product is intended for industrial use. In a domestic environment this product may cause radio interference. It is the user's responsibility to take adequate precautions.**

 **WARNING**

Precautionary measures should be taken to provide maximum protection against electrical shock. Be sure that all power is off by opening the line (wall) disconnect switch and unplug the power cord to the unit when primary electrical connections are made to the power supply.

 **WARNING**

**ELECTRIC SHOCK CAN KILL!** Precautionary measures should be taken to provide maximum protection against electric shock. Be sure that all power is off by opening the line (wall) disconnect switch and by unplugging the power cord to the unit when connections are made inside of the power source.

### 3.0 Installation

Proper installation can contribute materially to satisfactory and trouble-free operation of the cutting outfit. Each step in this section should be studied carefully and followed as closely as possible.

#### 3.1 Inspection and Placement

1. Having removed the shipping container, and before removing the skid, inspect for evidence of concealed damage which may not have been apparent upon receipt of the unit. Notify the carrier of any defects or damage at once.

2. Check the container for any loose parts. Check air passages on rear panel of cabinet for any packing materials that may obstruct air flow through the power supply.

The ESP-150 Power Source is equipped with one lifting eye that enables hoisting the unit. Be sure the lifting device has adequate capacity to lift the unit safely. Refer to the SPECIFICATIONS for the unit weight.

3. Mount the components of the TR-21 Truck Kit to the unit as covered by Form F-14-413 packed with the truck kit.
4. The machine components are maintained at proper operating temperatures by forced air which is drawn through the front panel louvers and holes in the base and out the rear panel by a heavy-duty fan. Locate this machine in an open area where air can circulate freely through the openings. Leave at least two feet of clearance between the unit and wall or other obstruction. The area around the unit should be relatively free of dust, fumes and excessive heat. *(Installing or placing any type of filtering device will restrict the volume of intake air, thereby subjecting the power source internal components to overheating. Use of any type of filter device voids the warranty.)*
5. A source of clean, dry air that supplies a minimum of 250cfh (7.08 M<sup>3</sup>H at 110 psig) is required for the cutting operation. The air supply should not exceed 150psig (10.3 bars) - maximum inlet pressure rating of the filter regulator supplied with the package.

**! WARNING**

Precautionary measures should be taken to provide maximum protection against electrical shock. Be sure that all power is off by opening the line (wall) disconnect switch and unplugging the power cord to the unit use proper lockout safety procedures when making primary electrical connections to the power supply.

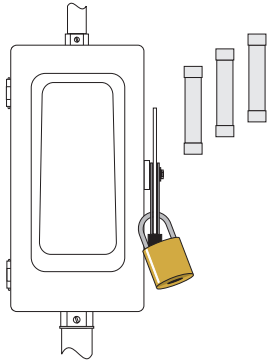

**! WARNING**

It is of the utmost importance that the chassis be connected to an approved electrical ground to prevent accidental shocking. Take care not to connect the ground wire to any of the primary leads.

**3.2 Primary Input Electrical Connections**

1. A line (wall) disconnect switch, with fuse or circuit breakers, should be provided at the main power panel. See Fig. 3. The primary power leads should be insulated copper conductors, and include three power leads and one ground wire. The wires may be heavy rubber covered cable, or may be run in a solid or flexible conduit. Refer to Table 1 for recommended input conductors and line fuse sizes.

**FIG 3. Typical Installation - User Supplied 3 Phase Fused Power Disconnect Box with Receptacle and Plug**

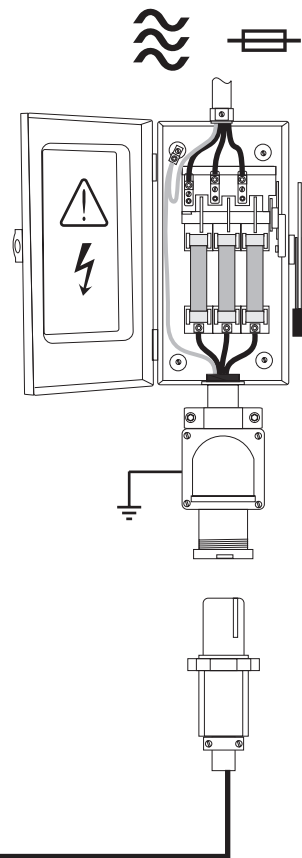
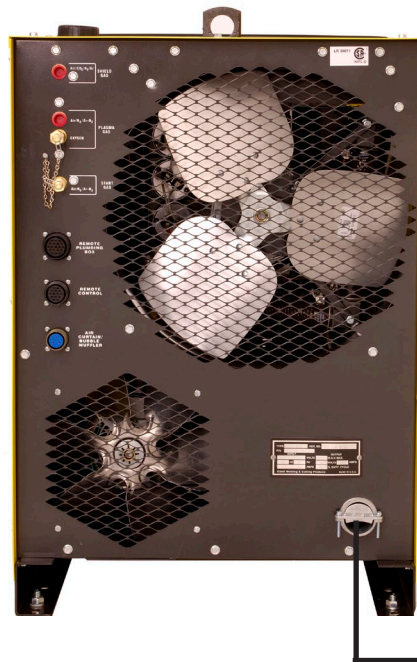

**Table 3-1. Input Conductor and Line Fuse Size Recommendations**

| Input Requirements |       |      | Input & Gnd. Conductor CU/AWG | Fuse Ratings /Phase, Amps |
|--------------------|-------|------|-------------------------------|---------------------------|
| Volts              | Phase | Amps |                               |                           |
| 220                | 3     | 121  | No. 1                         | 150                       |
| 230                | 3     | 116  | No. 1                         | 150                       |
| 380                | 3     | 70   | No. 4                         | 100                       |
| 415                | 3     | 64   | No. 6                         | 90                        |
| 460                | 3     | 58   | No. 6                         | 80                        |
| 575                | 3     | 45   | No. 6                         | 70                        |

Sizes per National Electrical Code for 75° rated conductors @ 30°C ambient. Not more than three conductors in raceway or cable. Local codes should be followed if they specify sizes other than those listed above.



**! WARNING**

**ELECTRIC SHOCK CAN KILL!** Precautionary measures should be taken to provide maximum protection against electric shock. Be sure that all power is off by opening the line (wall) disconnect switch by unplugging the power cord to the unit or use proper lock out safety procedures when making connections inside of the power source.

2. **60 Hz Models** - As shipped from the factory, the ESP-150 is configured for the highest connectable voltage. If using other input voltages, the links on the terminal board (TB) inside the unit must be repositioned for the appropriate input voltage. See the figures 4a,b & c input voltage configurations. To gain access to the terminal board, open the access panel on the left side.

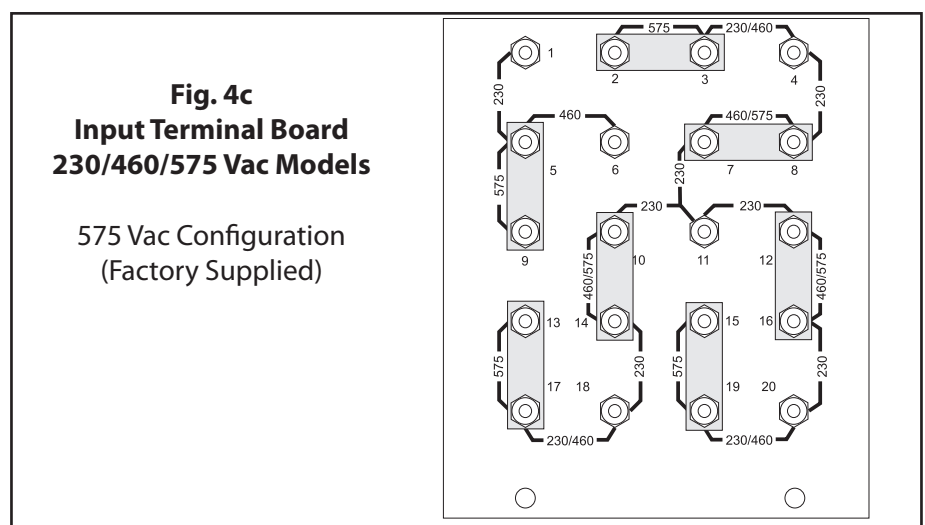
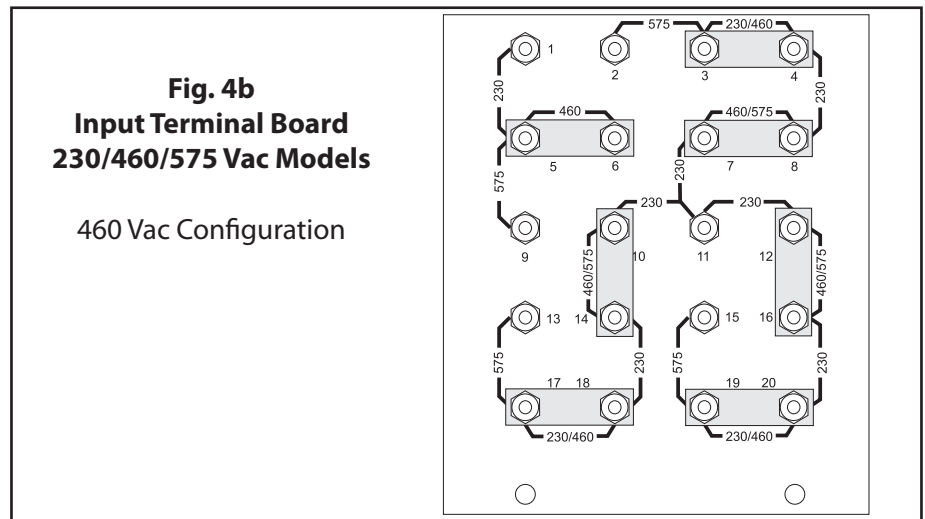
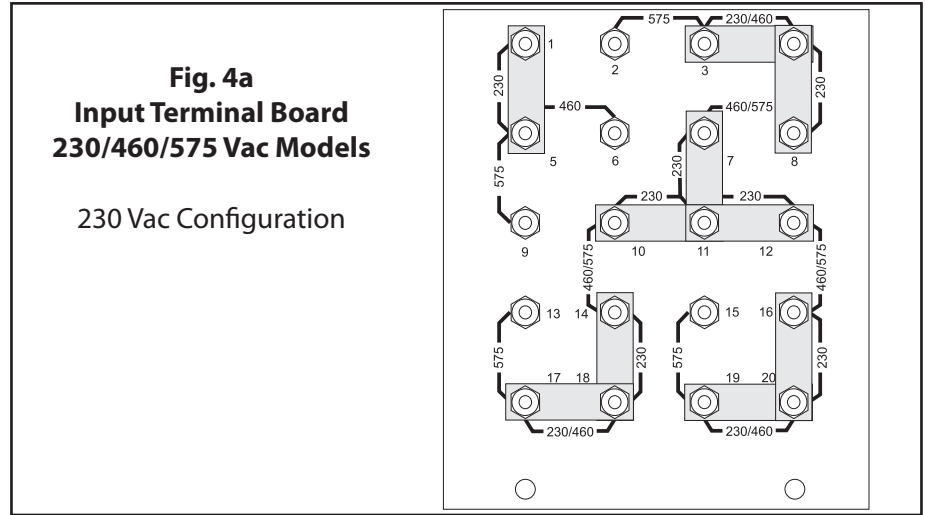

### ! WARNING

Before making any connections to the power source output terminals, make sure that all primary input power to the machine is de-energized (off) at the disconnect switch.

### ! WARNING

A poor connection or failure to connect work cable to workpiece can result in fatal shock.

Failure to connect the workpiece to earth ground will result in the opening of FUSE F3 and CIRCUIT BREAKER CB1, disabling the console.

- Safety codes specify that the Power Cable GROUND wire be the last to break connection should the cable be pulled out of the unit. Be sure to cut and strip wire as shown in Figure 6.

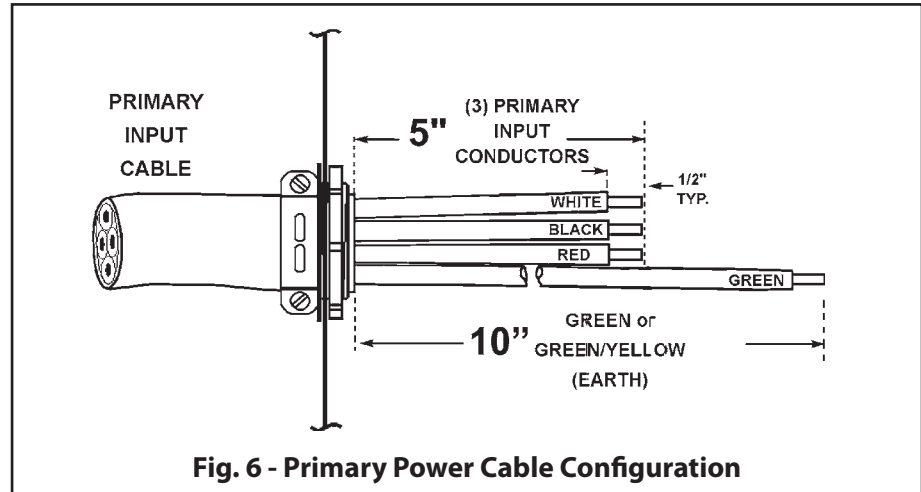

Fig. 6 - Primary Power Cable Configuration

- Thread the input conductor cable from the wall disconnect switch through the strain relief in the rear panel of the main contactor (MC). Connect the primary power leads to the main contactor terminals (see Figure 7) using UL listed pressure wire connectors. Also connect the ground wire to the stud provided on the chassis base inside the left-rear of the cabinet. Secure the input cable by tightening the strain relief coupling.

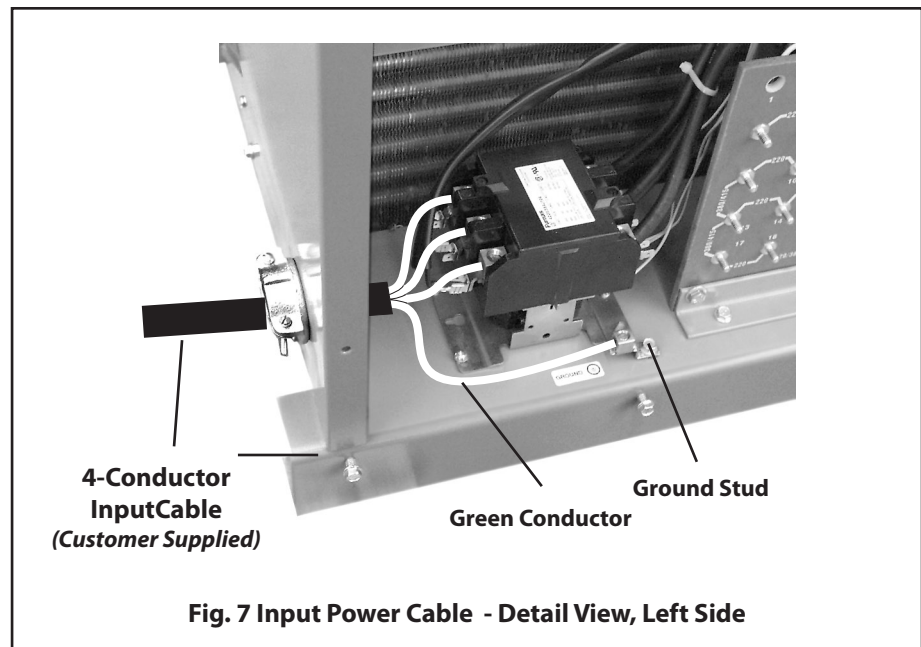
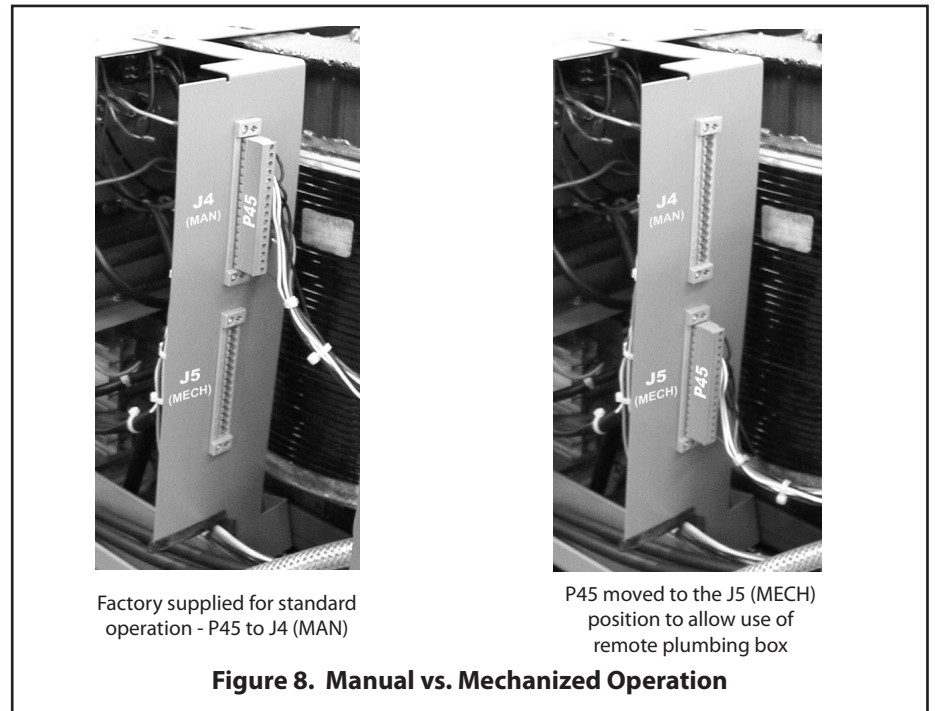

Fig. 7 Input Power Cable - Detail View, Left Side

- Recheck all connections to make sure that they are tight, well insulated, and the proper connection has been made. Then close access panel and reinstall fasteners.

6. **Control Mode Selection for Operation with Remote Plumbing Box**  
 The ESP-150 is supplied from the factory with Plug P45 connected to the J4 (MAN) receptacle (torch gases and torch connected directly to the ESP-150 power source). If the unit is to be used with a remote plumbing box, move P45 to the J5 (MECH) receptacle.



**NOTE: If CNC does not have a normally closed emergency stop switch, a jumper must be installed between TB1-16 and TB1-20.**

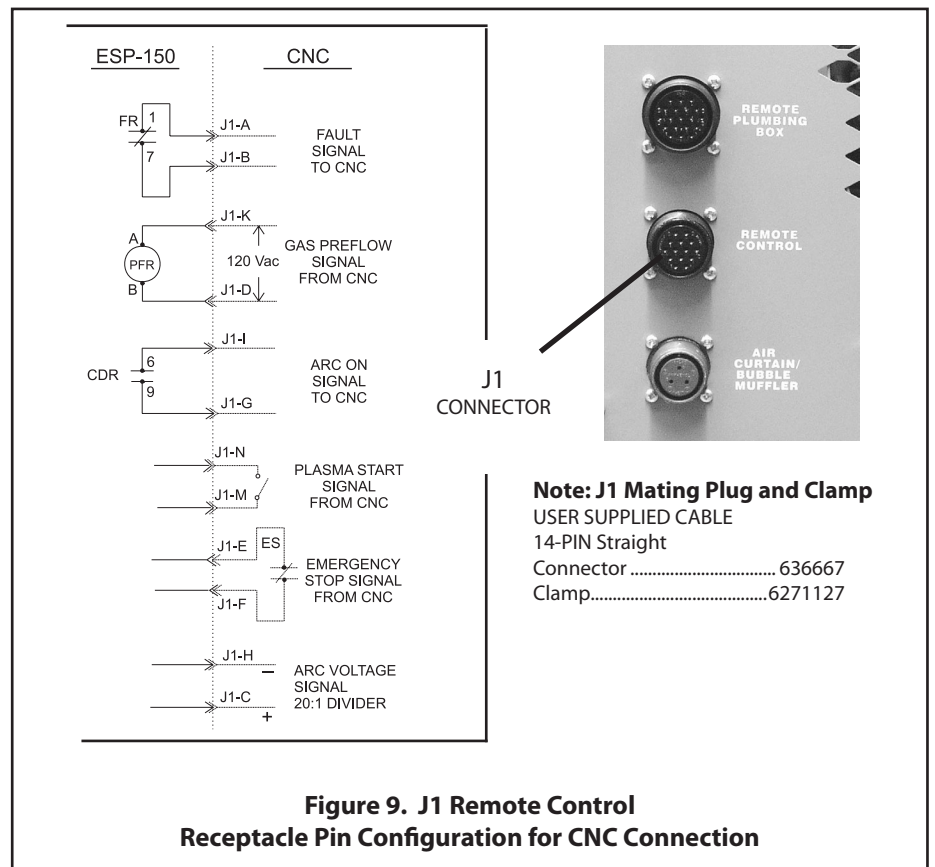

**WARNING** MAKE SURE POWER SWITCH ON CONSOLE IS IN OFF POSITION AND PRIMARY INPUT POWER IS DE-ENERGIZED.

### 3.3 Voltage Divider Adjustment

It may be necessary to adjust the Voltage Divider or VDR to match the particular height control system. There are two default settings for the PowerCut models as shipped from the factory:

- STANDARD UNITS (Non-CE): 750 ohms (21:1)
- CE UNITS (Europe): 789 ohms (20:1)

If the height control system does not match the factory default setting, matching can be accomplished by adjusting the VDR potentiometer.

1. Place ohm meter leads between W2 (arc voltage) & W3 (work). Adjust R1 to achieve the desired divide ratio for the particular height control system used. For example:
  - 16:1 ratio 1000 ohms
  - 18:1 ratio 882 ohms
  - 21:1 ratio 750 ohms
  - 20:1 ratio 789 ohms
2. If desired, additional minor adjustments of the VDR potentiometer may be made. Any adjustments should be performed by a qualified technician.

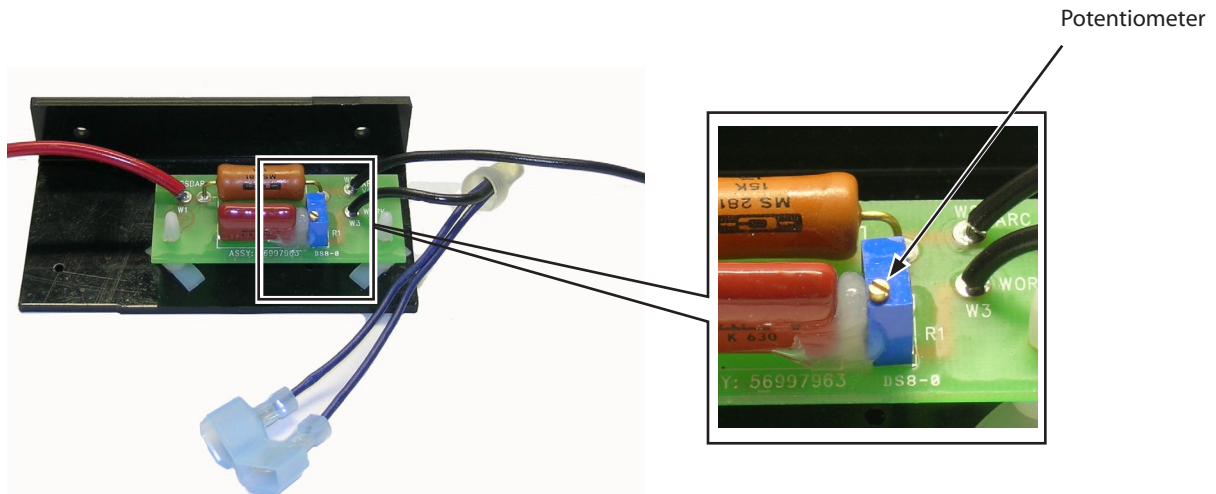

### 3.4 Torch Connections

1. Open top front cover to gain access to the torch connections.(Fig. 10)
2. Thread the five service lines (gas, power, and switch lead) of the PT-26 torch through bushing at upper left corner of the front panel and connect them to the matching fittings on output terminal. Hose connections should be wrench-tight. Make sure plug of the switch lead is firmly locked in place. Then close and reinstall the hinged cover.
  - a. If a PT-26 In-line Torch is being used in a mechanized installation where only an arc start signal is required, connect the optional Remote Hand Switch, ESAB part number 2075600, to the Torch Switch Receptacle on the hook-up panel in the front of the ESP-150 console. Fig. 11.
  - b. If a PT-26 In-line Torch is being used in a mechanized installation with a CNC device, see Fig. 9 for Remote Control Receptacle I/O signal pin configuration and Fig. 8 for Control Mode Selection instructions.

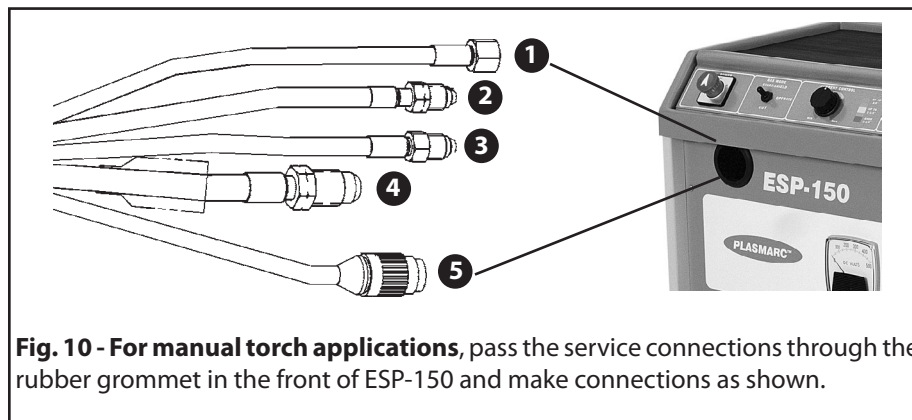

**Fig. 10 - For manual torch applications**, pass the service connections through the rubber grommet in the front of ESP-150 and make connections as shown.

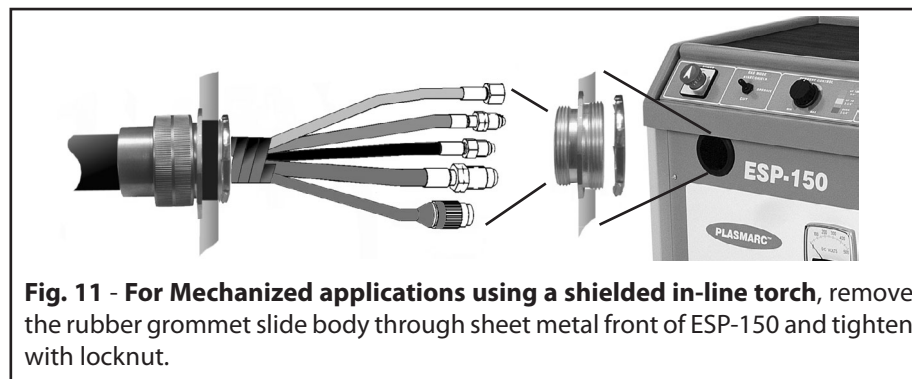

**Fig. 11 - For Mechanized applications using a shielded in-line torch**, remove the rubber grommet slide body through sheet metal front of ESP-150 and tighten with locknut.

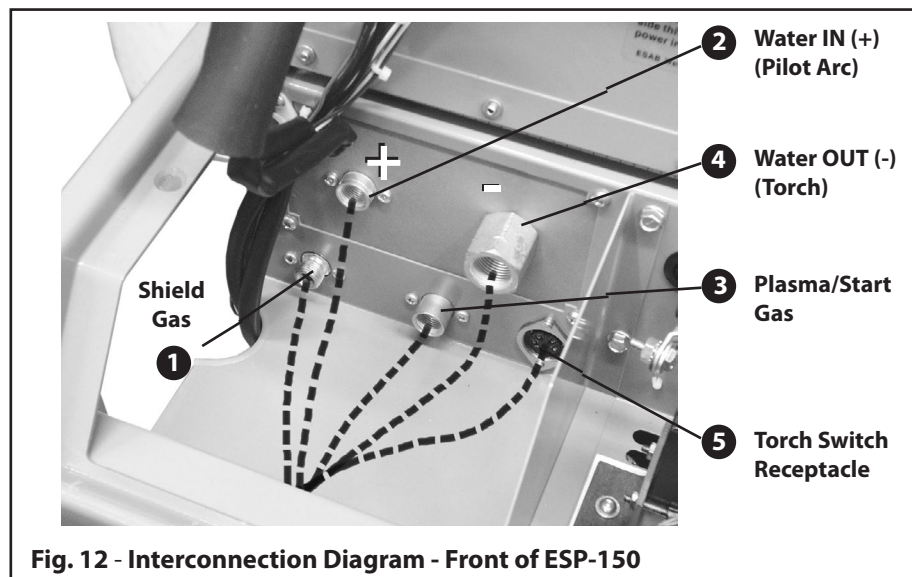

**Fig. 12 - Interconnection Diagram - Front of ESP-150**

**3.5 Gas Supply Connections**

1. Connect the gas supplies. The cylinders may be placed and secured on the cylinder rack of the truck. Before connecting the regulators, be sure to read, understand, and follow all instructions packed with each regulator.
2. Connect the gas hoses to the regulators and to the proper fittings (Adaptors: 74S76, Air; 19X54, Ar/H<sub>2</sub>) on the rear panel of the ESP-150. Connections should be wrench tight including those that are plugged. (Fig. 14)

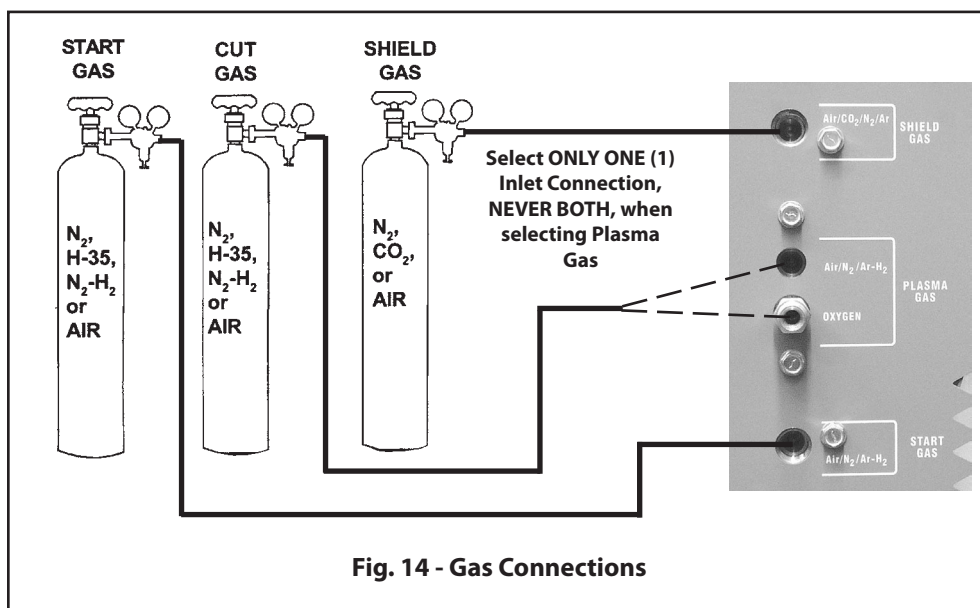
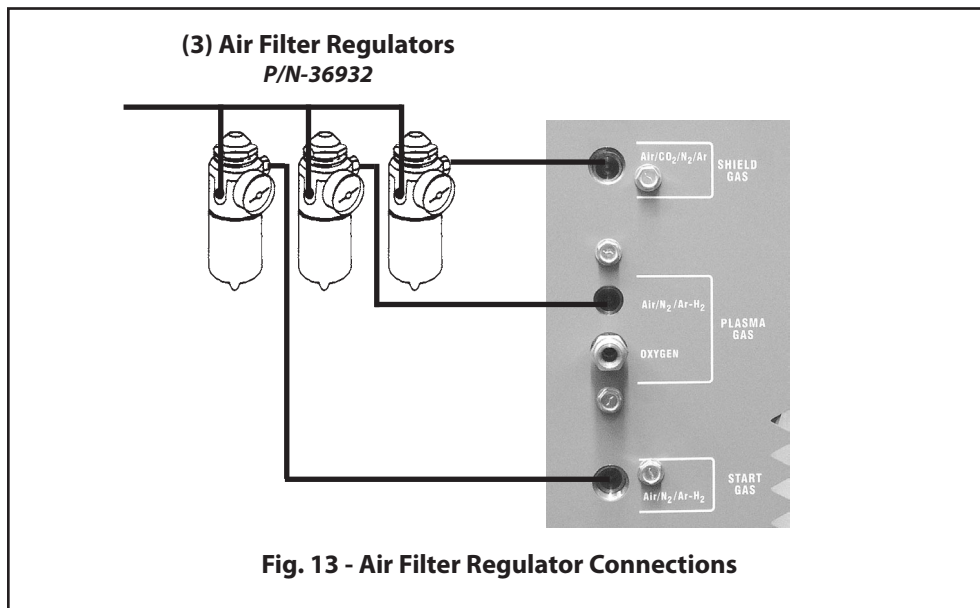

### CAUTION

Operating the unit without coolant will cause permanent damage to coolant pump.

### WARNING

Do not use commercial antifreeze or tap water. Equipment will malfunction and damage will occur.

## 3.6 Work and Earth Connections

1. Connect terminal lug end of the work cable assembly to stud on lower left corner of front panel. Nut should be wrench tight. (Fig. 15). Electrically connect work cable to work piece. The connection must be made to a clean, exposed metal surface free of paint, rust, mill scale, etc. (Fig. 15).
2. Make sure workpiece is connected to an approved earth ground. Use copper ground cable equal to or larger than the power supply chassis ground listed in Table 1.

## 3.7 Torch Coolant Preparation

1. Remove the cap from the coolant filter tank. Fill coolant tank with 2 gallons (7.5 liters) of plasma system coolant (P/N 156F05) - supplied with the package. The coolant also provides antifreeze protection down to -34°.

Due to high electrical conductivity, use of tap water or commercial antifreeze is NOT recommended for torch cooling. Use of tap water can result in algae growth in the water cooler and torch. Automotive type antifreeze will adversely affect starting and will form deposits in the torch that will cause damage.

2. With installation completed, check all gas and coolant fittings for leaks using a standard solution.

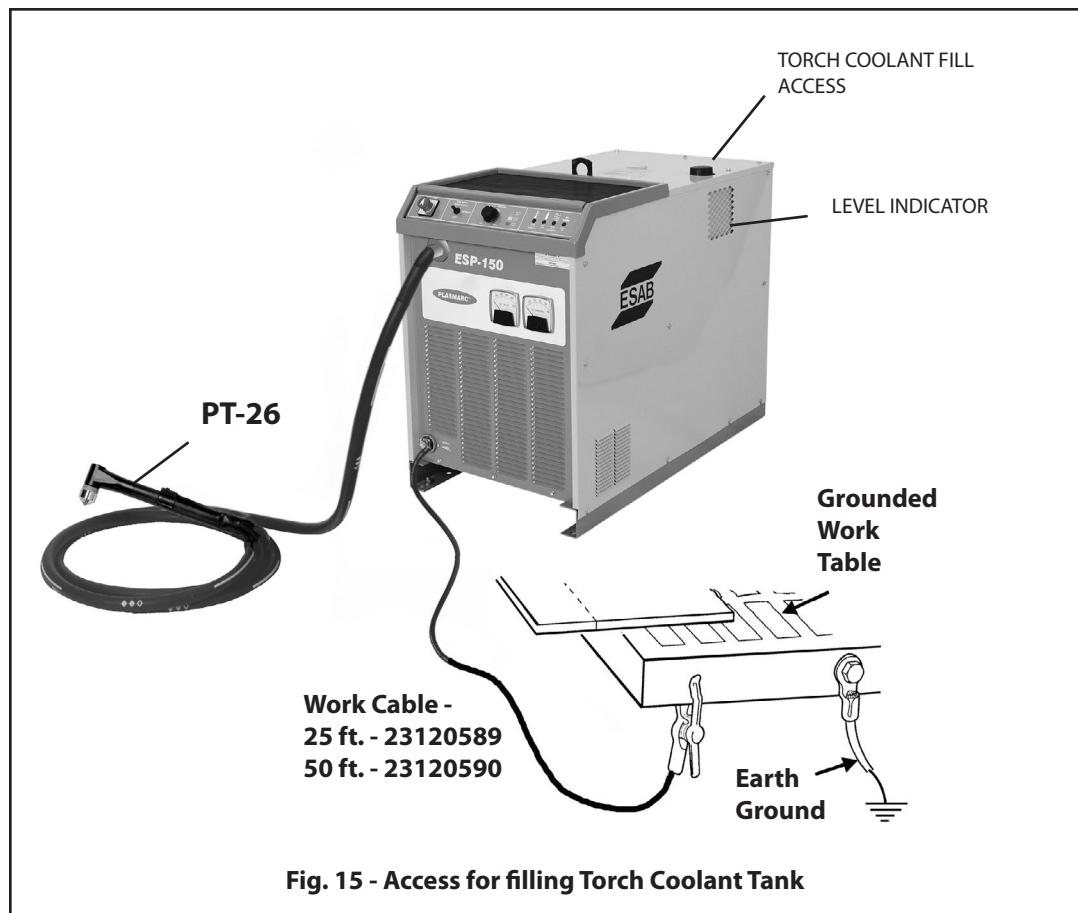





## 4.0 Operation

### 4.1 Controls and Indicators

This section provides descriptions of the power source controls and general operating procedures plus, some tips on cut quality.



- 1 Topping up the coolant
- 2 Level indicator for the coolant
- 3 Connection for return cable
- 4 Ampere and Voltmeter
- 5 Connection for torch
- 6 Mains voltage switch
- 7 Switch for gas
- 8 Current setting control
- 9 Indicator lamps



The status lights located on the front of the top lid of the ESP-150 console provide the conditions of the circuitry during a normal plasma arc cutting operation. By knowing the proper sequencing of events and by observing the status lights one can troubleshoot the console in a short time to minimize downtime.

None of these lights will function unless proper input voltage is applied with the links on the input terminal board (TB) properly connected for the input voltage; the ON-OFF power switch is ON; and the top lid of the console is closed firmly.

The following are the functions of each light:

**POWER (ROS)** — Energizes power to the Fan, Water Cooler and Control Circuitry. This readies the unit for operation.

**GAS MODE (OSS)** — CUT - Allows for setup of cut gas pressure and flow; START/SHIELD - allows setup of start and shield gas pressure and flow; and OPERATE - position to use for cutting operations.

**CURRENT CONTROL** — Controls desired cutting current for optimizing speed and cut thickness. See Section 4.6 Cut Data.

**OVER TEMP** — Will light if any (one or more) thermal switch in the console is open due to overheating. (This light may be dim when the gas flow is in the post-flow mode.) If light comes on, stop cutting operations and allow unit to cool down (with fan running) until light goes out. If the light is on and you suspect the unit is cool, then check for defective thermal switch(es) or loose connections.

**READY/LOW GAS** — This light serves as a READY light, torch switch and operate/set switch check as well as low gas flow or pressure indicator. It will light when the unit is at rest or READY (power ON-OFF switch is ON). It will continue to be lit when operate/set switch (OSS) is placed in the SET position even when proper gas flow or pressure is set properly. The light will not go out when the OSS switch is placed in the OPERATE position (gas solenoid valves will shut off).

In the operate mode, this light will then function as a LOW GAS light. After depressing the torch switch button and the LOW GAS lights up during a cutting operation, gas pressure or flow is insufficient.

**HIGH FREQ ENERGIZED** — This will light when the unit is in the OPERATE mode and the torch switch button is depressed. It should remain lit until the main cutting arc is established. It indicates that proper voltage (approx. 115 VAC) is applied to the primary of the high frequency transformer (HFTR). The voltage is applied to the HFTR through proper operation of the pilot arc contactor (PAC).

**TORCH ON** — This will light when the power supply is delivering the voltage to generate an arc (whether or not the main arc has been established). It is indicating there is greater than 50 volts between NEG output and WORK terminals. **Never touch the front end parts or make any adjustments to the torch if the TORCH ON light is on, even when the power ON-OFF is OFF.**

**! CAUTION**

Never, under any circumstances, operate the power supply with the cover removed. In addition to the safety hazard, improper cooling may cause damage to internal components. Keep side panels closed when unit is energized. Also make sure you are adequately protected before you start cutting — protective helmet and gloves should always be worn. Refer to Safety Section for additional operating precautions.

**! CAUTION**

Voltage is available at the POWER On-Off switch on the hinged top cover when voltage is applied to the input terminal board even when the POWER switch is OFF.

**! WARNING**

Before making any adjustments or performing any maintenance on the torch, make sure the power to the torch is shut off.

**! WARNING**

**ARC RAYS CAN BURN EYES AND SKIN, NOISE CAN DAMAGE HEARING!**

**Wear eye, ear, and body protection.**

Wear the usual protective gloves, clothing, and helmet. Helmet with filter lens shade No. 6 or 7 should provide adequate protection for your eyes.

Never touch any parts forward of the torch handle (tip, heat shield, electrode, etc.) unless the Power switch is in the OFF position.

**4.2 ESP-150 Adjustments**

1. Slowly open each gas cylinder valve.
2. Place the ESP-150 GAS MODE and POWER switches in the OPERATE and OFF positions.
3. Place the primary (wall) switch in the ON position.
4. Place POWER to READY position. POWER light should light up. Fan should be running.
5. With GAS MODE switch in START/SHIELD position gas solenoid valves should be open. Adjust the START gas and SHIELD regulators to deliver the pressures specified in Table 2. Place switch in CUT position and adjust CUT Gas regulator to deliver pressures specified in Table 2.
6. Allow the gases to flow for a few minutes. This should remove any condensation that may have accumulated during shut down.
7. Place the GAS MODE switch in the OPERATE position. This will shut off the gas flows.
8. Adjust CURRENT CONTROL knob to approximate cutting current desired.

**4.3 Operation**

1. Position the torch on the workpiece by resting the heatshield on the edge of the workpiece where you intend to start the cut.
2. Lower your protective helmet and then lift the torch approximately 1/8" above the workpiece.
3. Push down on the torch switch button mounted on the torch handle. Pilot arc contactor and high frequency will energize, and gas will start flowing. Two seconds later, the main contactor will come on. The pilot arc should then transfer to the cutting arc.

*NOTE: If cutting arc does not start within 6 seconds, the pilot arc will shut off. Release torch switch. Check to be sure gas pressures are adequate, work cable is firmly connected to workpiece, torch was approximately 1/8" to 1/4" above workpiece, etc. Then start from step 1 again.*

4. For manual and mechanized cutting, maintain a standoff (torch-to-work distance) of approximately 3/8". (stand off guide, P/N 36648, provides that distance). Keep the torch head vertical, and move it at a rate that produces the desired cut quality. The cutting should produce a straight fine spray of molten metal emitting from beneath the workpiece as illustrated in Fig. 16. For mechanized cutting, see Table 2 or 3 for recommended cutting speed range.
5. If cutting arc is lost during a cut, the pilot arc will immediately reignite as long as the torch switch is depressed. You then have approximately 6 seconds to move the torch close enough to work to re-establish the cutting arc.

### ! WARNING

Do NOT operate the unit with the cover removed.

Do NOT apply power to the unit while holding or carrying the unit.

Do NOT touch any torch parts with power switch on.

### ! CAUTION

Position the ESP-150 at least 10 feet (3 meters) from the cutting area. Sparks and hot slag from the cutting operation can damage the unit.

6. The cutting arc will extinguish at the end of the cut; however, the torch switch should be released to keep the pilot arc from reigniting.
7. When cutting operation is completed, wait a few minutes before placing the POWER switch to the OFF position so that the cooling fan has time to remove the heat from the unit. Then shut off the primary power at the main disconnect switch.

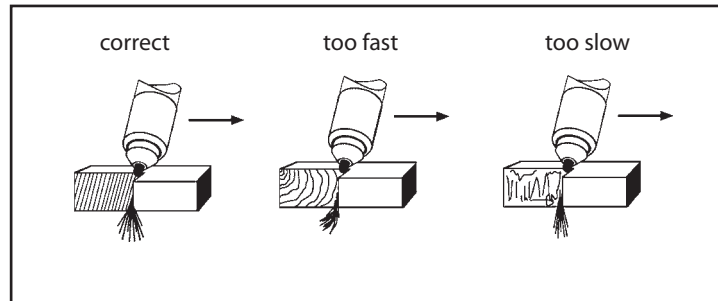

**Fig. 16 - Effect of Cutting Speed**

With a positive cut angle, the top dimension is slightly less than the bottom dimension. With a negative cut angle, the top dimension is slightly greater than the bottom dimension. The cut angle is controlled by the standoff (arc voltage), cutting speed and cutting current. If the cutting speed and the cutting current are correct and the part has an excessive positive angle, then the standoff is too high. Begin lowering the arc voltage in increments of 5 volts, observing cut squareness. There will always be slight top edge rounding of the part when using Nitrogen.

The optimum torch height is a point just before the part begins to develop a negative cut angle. To expand upon the other two variables; with the correct torch standoff, excessive cutting speed will result in a positive cut angle; insufficient cutting speed will produce a negative cut angle. If the cutting current is too high or low, a positive cut angle will be produced.

Arc Voltage/Standoff - Interactive parameters that are proportional. The higher the torch above the plate (standoff), the higher the operating voltage required and vice versa.

Lag Lines - These lines appear on the cut surface. They are of assistance in determining if your process parameters are correct.

**4.4 Standoff and Cut Quality**

Standoff (Arc Voltage) has a direct influence on cut quality and squareness. It is recommended that prior to cutting, that all cutting parameters are set to the manufacturer's suggested conditions. Refer to the Process Tables for recommendations. A sample cut should be made using actual part material followed by close examination of the part.

If the cut face of the part has excessive bevel or rounded top edge, it may be that the standoff is set too high. When standoff is controlled by an arc voltage height control, reducing the arc voltage setting will reduce the standoff.

Lower the standoff until the excessive bevel or rounded top edge disappears. The characteristics of plasma cutting hinder production of a perfectly square cut. On material thicknesses of 1/4 inch or greater, a standoff too close may result in a negative cut angle.

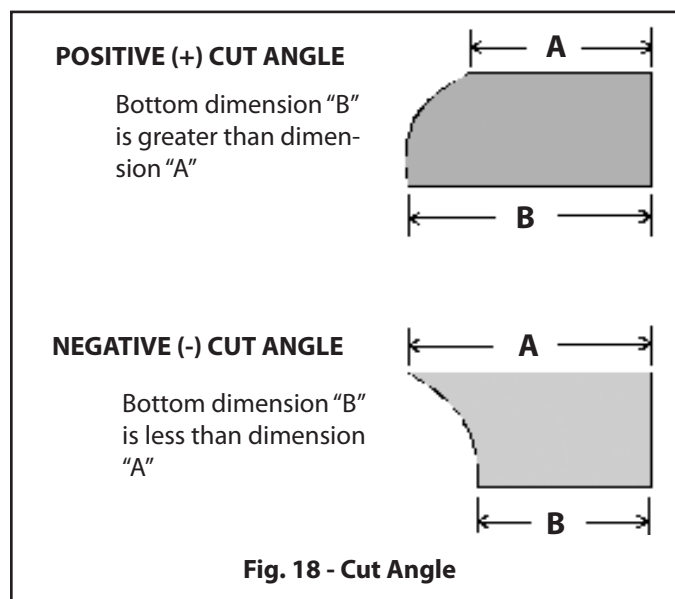
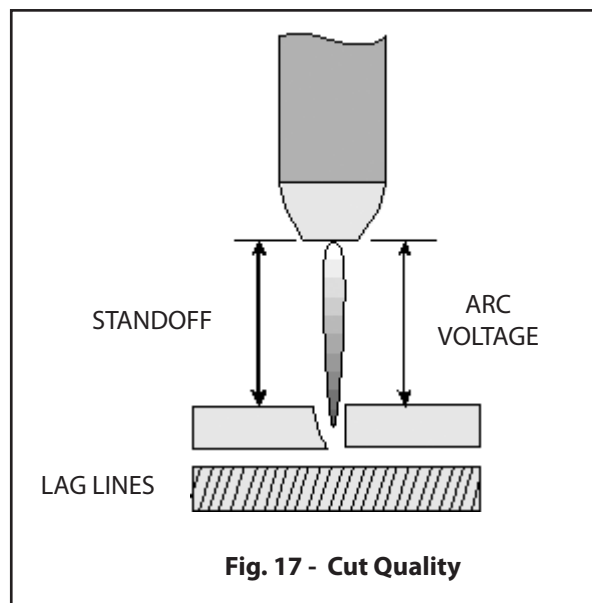

### 4.5 Dross Formation

Cutting speed, gas selection and variations in metal composition contribute to dross formation. The correct cutting standoff also has an influence on dross formation. If the arc voltage is set too high, the cut angle becomes positive. In addition, dross forms on the bottom edge of the part. This dross can be very tenacious and require chipping and grinding for removal. Setting the cutting voltage too low results in undercutting the parts or negative cut angle. Dross formation occurs but in most cases it is easily removed.

#### Top Dross

Top dross usually appears as splatter near the top edge of the kerf. This is a result of torch standoff (arc voltage) set too high or cutting speed set too fast. Most operators use the parameter charts for recommended speed. The most common problem is torch standoff or arc voltage control. Simply lower the voltage settings in increments of 5 volts until the top dross disappears. If an arc voltage control is not used, the torch can be lowered manually until the dross disappears.

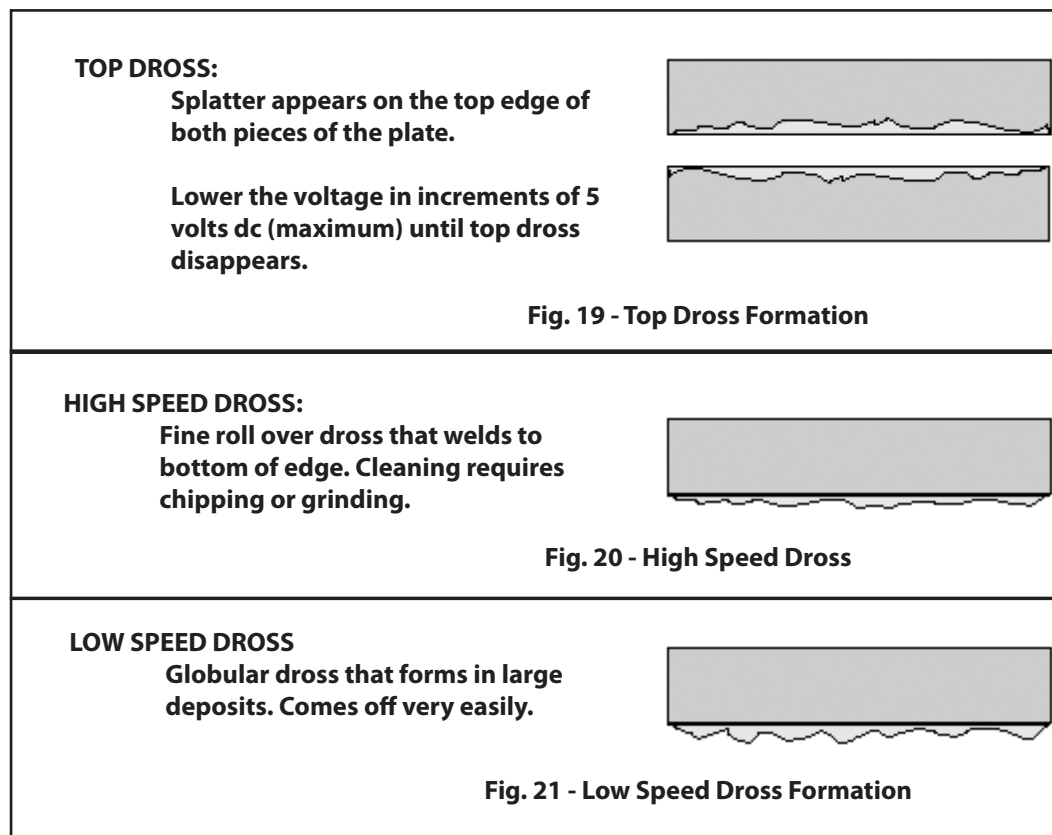

#### SUMMARY

Arc voltage is a dependent variable. It is dependent upon cutting amperage, nozzle size, torch standoff, cut gas flow rate and cutting speed. An increase in arc voltage can result from a decrease in cutting speed, an increase in cutting amperage, a decrease in nozzle size, an increase in gas flow and an increase in torch standoff. Assuming that all of the variables are set as recommended, torch standoff becomes the most influential variable to the process. Good and accurate height control is a necessity in producing excellent cut quality.



Tripped circuit breaker (located under the top hinged cover) may indicate dangerous high voltage existed between the work cable and earth ground. This is usually caused by a missing or poor connection of the work cable to the work piece. The work cable **MUST** be electrically connected to the work piece to prevent dangerous shock conditions.

## 4.6 Common Cutting Problems

The following is a listing of common cutting problems and the probable cause. If problems are determined to be caused by the ESP-150, refer to the maintenance section of this manual. If the problem is not corrected after referring to the maintenance section, contact your ESAB representative.

### A. Insufficient Penetration:

1. Cutting speed too fast
2. Damaged cutting nozzle
3. Improper gas settings
4. Inadequate delay for pierce

### B. Main Arc Extinguishes:

1. Cutting speed too slow

### C. Dross Formation:

1. Cutting speed too fast or too slow
2. Improper air pressure
3. Faulty nozzle or electrode
4. Improper standoff
5. Current too low

### D. Double Arcing:

1. Low air pressure
2. Damaged cutting nozzle
3. Loose cutting nozzle
4. Heavy spatter
5. Nozzle touches work while cutting
6. Pierce height too low
7. Current too low

### E. Uneven Arc:

1. Damaged cutting nozzle or worn electrode

### F. Unstable Cutting Conditions:

1. Incorrect cutting speed
2. Loose cable or hose connections
3. Electrode and/or cutting nozzle in poor condition

### G. Main Arc Does Not Strike:

1. Loose connections
2. Work clamp not connected
3. Gas pressures not correct
4. Insufficient coolant to operate flow switch

### H. Poor Consumable Life:

1. Improper gas pressure
2. Contaminated air supply
3. Improper gas/electrode combination
4. Torch hitting work piece or turned up parts
5. Parts damaged by double arcing (see D above)
6. Use of non-genuine parts
7. Water leaks in torch
8. Torch not purged after changing consumables or idle period
9. Using wrong consumables for selected gases

**4.7 Operating Parameters**

Recommended Gas Pressures -

- Start ..... 30 psig
- Plasma (Cutting) ..... 50 - 70 psig
- Plasma (Gouging) ..... 40 - 45 psig
- Shield..... 40 - 50 psig

Recommended Stand-off -

5/16" - 1/2"

Travel Speeds -

Travel speeds for the PT-26 are given in Tables 4-1 through 4-4.

**4.8 Cut Data**

**To ensure optimum cutting performance and aid in troubleshooting any cut quality problems, please refer to the following cutting parameters charts.**

The cutting speeds and conditions in the following tables were selected to give the best quality with a particular gas combination at a specific current.

Consumables - Refer to PT-26 Torch manual for recommended parts for these conditions. Use of parts in combinations and applications other than as described herein can result in damage to the torch or poor performance.

Gas and Current Selection- Refer to the following tables to choose the most appropriate conditions for your application.

**PT-26 in-line torch cutting conditions:**

Data taken with Swirl Baffle (0558003583) and Shield Cup (0558003582).

65 Amp data uses standard Heat Shield (34592) or Close Proximity Heat Shield (37146) in place of Shield Cup (0558003582) and uses a 50 Amp Nozzle (36567).



**Table 4.1 65 Amp Cut Data**

| Material           | Thickness<br>inch (mm) | Standoff<br>inch (mm) | Speed<br>ipm (mm/m) | Start Gas and<br>Pressure<br>psig (bar) | Cut Gas and<br>Pressure<br>psig (bar) | Shield<br>Gas and Pressure<br>for ESP-150 and 200<br>psig (bar) |
|--------------------|------------------------|-----------------------|---------------------|---|---------------------------------------|---|
| Carbon<br>Steel    | 0.12 (3.2)             | 0.19 (4.8)            | 190 (4826)          | Air<br>30 (2.1)                         | Air<br>60 (4.1)                       | Air<br>50 (3.4)   |
|                    | 0.25 (6.4)             |                       | 100 (2540)          |   |                                       |   |
|                    | 0.50 (12.7)            | 0.25 (6.4)            | 30 (762)            |   |                                       |   |
| Aluminum           | 0.12 (3.2)             | 0.19 (4.8)            | 50* (1270)          |   |                                       |   |
|                    | 0.25 (6.4)             |                       | 70 (1778)           |   |                                       |   |
|                    | 0.50 (12.7)            | 0.25 (6.4)            | 20 (508)            |   |                                       |   |
| Stainless<br>Steel | 0.12 (3.2)             | 0.19 (4.8)            | 75 (1905)           |   |                                       |   |
|                    | 0.25 (6.4)             |                       | 50 (1270)           |   |                                       |   |
|                    | 0.50 (12.7)            | 0.25 (6.4)            | 20 (508)            |   |                                       |   |

Table 4.2 150 Amp Cut Data

| Material           | Thickness<br>inch (mm) | Standoff<br>inch (mm) | Speed<br>ipm<br>(mm/m) | Start Gas and<br>Pressure<br>psig (bar) | Cut Gas and<br>Pressure<br>psig (bar) | Shield<br>Gas and Pressure for<br>ESP-150 and 200<br>psig (bar) |
|--------------------|------------------------|-----------------------|------------------------|---|---------------------------------------|---|
| Carbon<br>Steel    | 0.19 (4.8)             | 0.19 (4.8)            | 150 (3810)             | Air / N <sub>2</sub><br>30 (2.1)        | O <sub>2</sub><br>60 (4.1)            | Air<br>60 (4.1)   |
|                    | 0.25 (6.4)             |                       | 130 (3302)             |   |                                       |   |
|                    | 0.38 (9.7)             |                       | 80 (2032)              |   |                                       |   |
|                    | 0.50 (12.7)            |                       | 70 (1778)              |   |                                       |   |
|                    | 0.62 (15.7)            | 0.25 (6.4)            | 50 (1270)              |   |                                       |   |
|                    | 0.75 (19.1)            |                       | 35 (889)               |   |                                       |   |
|                    | 1.00 (25.4)            |                       | 20 (508)               |   |                                       |   |
|                    | 0.19 (4.8)             |                       | 0.19 (4.8)             |   |                                       |   |
|                    | 0.25 (6.4)             | 0.25 (6.4)            | 130 (3302)             |   |                                       |   |
|                    | 0.38 (9.7)             |                       | 80 (2032)              |   |                                       |   |
|                    | 0.50 (12.7)            |                       | 70 (1778)              |   |                                       |   |
|                    | 0.62 (15.7)            |                       | 50 (1270)              |   |                                       |   |
|                    | 0.75 (19.1)            |                       | 35 (889)               |   |                                       |   |
|                    | 1.00 (25.4)            |                       | 20 (508)               |   |                                       |   |
| Aluminum           | 0.19 (4.8)             | 0.19 (4.8)            | 175 (4445)             | Air<br>30 (2.1)                         | Air<br>60 (4.1)                       | Air<br>60 (4.1)   |
|                    | 0.25 (6.4)             | 0.25 (6.4)            | 130 (3302)             |   |                                       |   |
|                    | 0.38 (9.7)             |                       | 90 (2286)              |   |                                       |   |
|                    | 0.50 (12.7)            | 0.31 (7.9)            | 70 (1778)              |   |                                       |   |
|                    | 0.62 (15.7)            |                       | 50 (1270)              |   |                                       |   |
|                    | 0.75 (19.1)            |                       | 35 (889)               |   |                                       |   |
|                    | 1.00 (25.4)            |                       | 25 (635)               |   |                                       |   |
| Stainless<br>Steel | 0.19 (4.8)             | 0.19 (4.8)            | 165 (4191)             | Air<br>30 (2.1)                         | Air<br>60 (4.1)                       | Air<br>60 (4.1)   |
|                    | 0.25 (6.4)             | 0.25 (6.4)            | 125 (3175)             |   |                                       |   |
|                    | 0.38 (9.7)             |                       | 80 (2032)              |   |                                       |   |
|                    | 0.50 (12.7)            | 0.31 (7.9)            | 50 (1270)              |   |                                       |   |
|                    | 0.62 (15.7)            | 0.38 (9.7)            | 35 (889)               |   |                                       |   |
|                    | 0.75 (19.1)            |                       | 20 (508)               |   |                                       |   |
|                    | 1.00 (25.4)            |                       | 10 (254)               |   |                                       |   |

**Table 4.3 200 Amp Cut Data**

| Material           | Thickness<br>inch (mm) | Standoff<br>inch (mm) | Speed<br>ipm<br>(mm/m) | Start Gas and<br>Pressure<br>psig (bar) | Cut Gas and<br>Pressure<br>psig (bar) | Shield<br>Gas and Pres-<br>sure for ESP-<br>150 and 200<br>psig (bar) |                 |                 |                 |
|--------------------|------------------------|-----------------------|------------------------|---|---------------------------------------|---|-----------------|-----------------|-----------------|
| Carbon<br>Steel    | 0.25 (6.4)             | 0.19 (4.8)            | 150 (3810)             | Air / N <sub>2</sub><br>30 (2.1)        | O <sub>2</sub><br>55 (3.8)            | Air<br>80 (5.5)   |                 |                 |                 |
|                    | 0.38 (9.7)             |                       | 95 (2413)              |   |                                       |   |                 |                 |                 |
|                    | 0.50 (12.7)            |                       | 80 (2032)              |   |                                       |   |                 |                 |                 |
|                    | 0.62 (15.7)            | 0.25 (6.4)            | 65 (1651)              |   |                                       | Air<br>30 (2.1)   | Air<br>55 (3.8) | Air<br>60 (4.1) |                 |
|                    | 0.75 (19.1)            |                       | 50 (1270)              |   |                                       |   |                 |                 |                 |
|                    | 1.00 (25.4)            |                       | 35 (889)               |   |                                       |   |                 |                 |                 |
|                    | 0.25 (6.4)             |                       | 135 (3429)             |   |                                       |   |                 |                 |                 |
|                    | 0.38 (9.7)             |                       | 95 (2413)              |   |                                       |   |                 |                 |                 |
|                    | 0.50 (12.7)            |                       | 85 (2159)              |   |                                       |   |                 |                 |                 |
|                    | 0.62 (15.7)            |                       | 70 (1778)              |   |                                       |   |                 |                 |                 |
|                    | 0.75 (19.1)            | 55 (1397)             |                        |   |                                       |   |                 |                 |                 |
|                    | 1.00 (25.4)            | 30 (762)              |                        |   |                                       |   |                 |                 |                 |
|                    | Aluminum               | 0.25 (6.4)            | 0.31 (7.9)             | 130 (3302)                              | Air<br>30 (2.1)                       |   |                 | Air<br>55 (3.8) | Air<br>80 (5.5) |
|                    |                        | 0.38 (9.7)            |                        | 105 (2667)                              |                                       |   |                 |                 |                 |
| 0.50 (12.7)        |                        | 85 (2159)             |                        |   |                                       |   |                 |                 |                 |
| 0.62 (15.7)        |                        | 75 (1905)             |                        |   |                                       |   |                 |                 |                 |
| 0.75 (19.1)        |                        | 60 (1524)             |                        |   |                                       |   |                 |                 |                 |
| 1.00 (25.4)        |                        | 40 (1016)             |                        |   |                                       |   |                 |                 |                 |
| Stainless<br>Steel | 0.25 (6.4)             | 0.25 (6.4)            | 130 (3302)             | Air<br>30 (2.1)                         | Air<br>55 (3.8)                       | Air<br>80 (5.5)   |                 |                 |                 |
|                    | 0.38 (9.7)             |                       | 115 (2921)             |   |                                       |   |                 |                 |                 |
|                    | 0.50 (12.7)            |                       | 75 (1905)              |   |                                       |   |                 |                 |                 |
|                    | 0.62 (15.7)            | 0.38 (9.7)            | 65 (1651)              |   |                                       |   |                 |                 |                 |
|                    | 0.75 (19.1)            |                       | 55 (1397)              |   |                                       |   |                 |                 |                 |
|                    | 1.00 (25.4)            |                       | 20 (508)               |   |                                       |   |                 |                 |                 |

Table 4.4 300 Amp Cut Data

| Material        | Thickness<br>inch (mm) | Standoff<br>inch (mm) | Speed<br>ipm<br>(mm/m) | Start Gas and<br>Pressure<br>psig (bar) | Cut Gas and<br>Pressure<br>psig (bar) | Shield<br>Gas and Flow<br>cfh (l/m) |
|-----------------|------------------------|-----------------------|------------------------|---|---------------------------------------|-------------------------------------|
| Carbon<br>Steel | 0.50 (12.7)            | 0.25 (6.4)            | 130 (3302)             | Air / N <sub>2</sub><br>30 (2.1)        | O <sub>2</sub><br>75 (5.2)            | Air<br>210 (99.1)                   |
|                 | 0.62 (15.7)            |                       | 95 (2413)              |   |                                       |                                     |
|                 | 0.75 (19.1)            | 0.31 (7.9)            | 80 (2032)              |   |                                       |                                     |
|                 | 1.00 (25.4)            |                       | 50 (1270)              |   |                                       |                                     |
|                 | 1.50 (38.1)            | 0.38 (9.7)            | 20 (508)               |   |                                       |                                     |
|                 | 2.00 (50.8)            | 0.50 (12.7)           | 10 (254)               |   |                                       |                                     |
|                 | 0.50 (12.7)            | 0.31 (7.9)            | 120 (3048)             |   | Air<br>75 (5.2)                       |                                     |
|                 | 0.62 (15.7)            |                       | 90 (2286)              |   |                                       |                                     |
|                 | 0.75 (19.1)            |                       | 80 (2032)              |   |                                       |                                     |
|                 | 1.00 (25.4)            |                       | 55 (1397)              |   |                                       |                                     |
|                 | 1.50 (38.1)            |                       | 0.38 (9.7)             |   |                                       |                                     |
|                 | 2.00 (50.8)            | 0.50 (12.7)           | 12 (305)               |   |                                       |                                     |

Maximum Manual PT-26 Speeds

PT-26 Steel Cutting Data

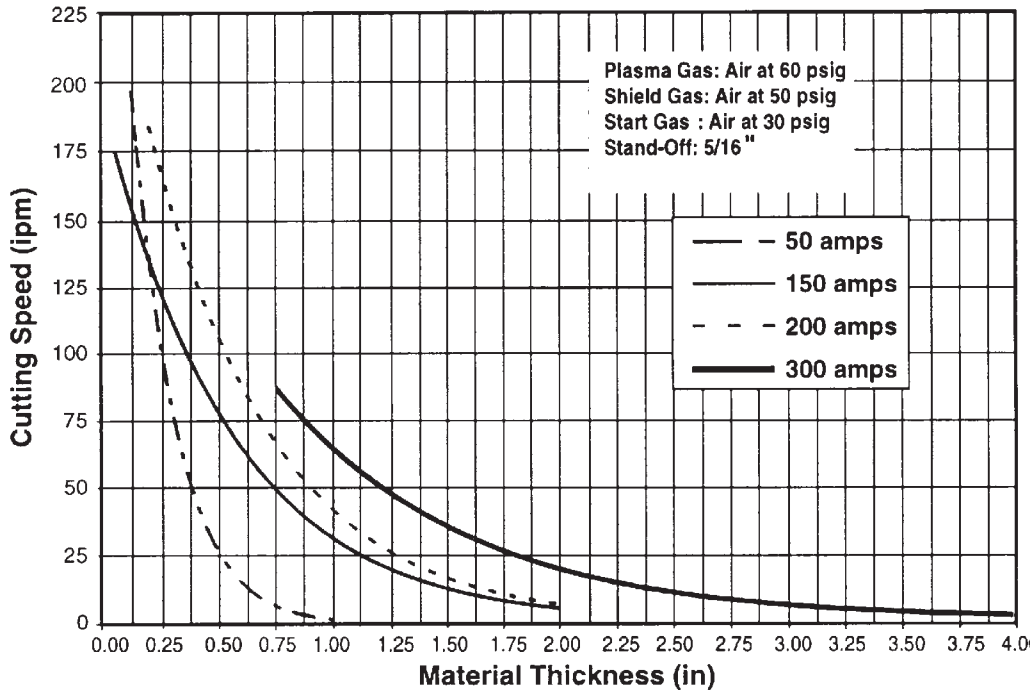

PT-26 Aluminum Cutting Data

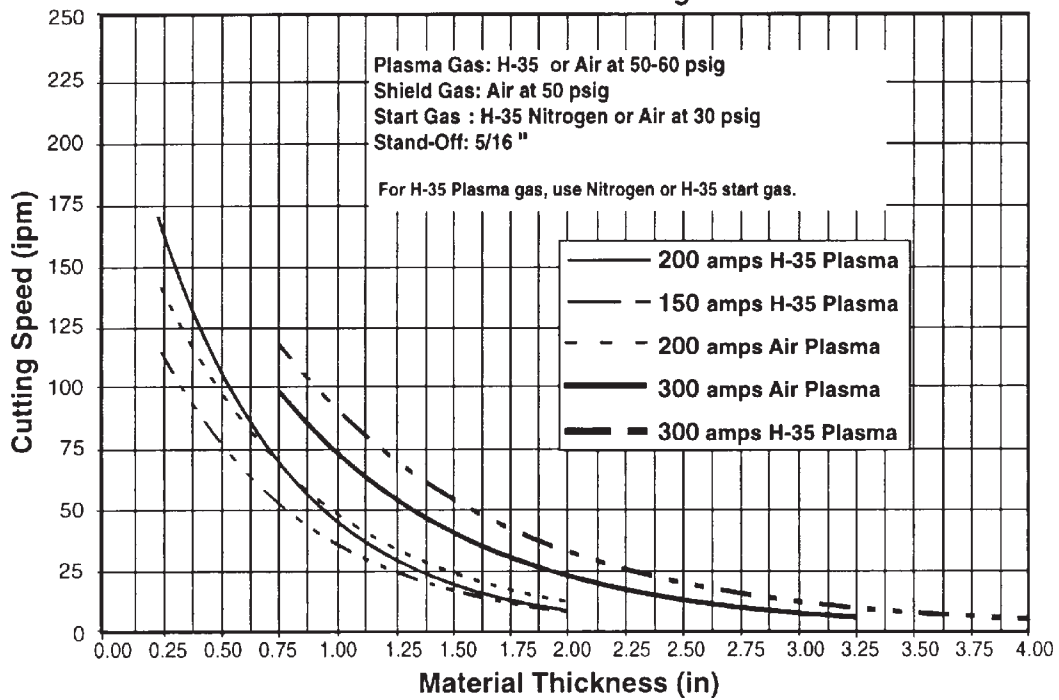

PT-26 Stainless Steel Cutting Data

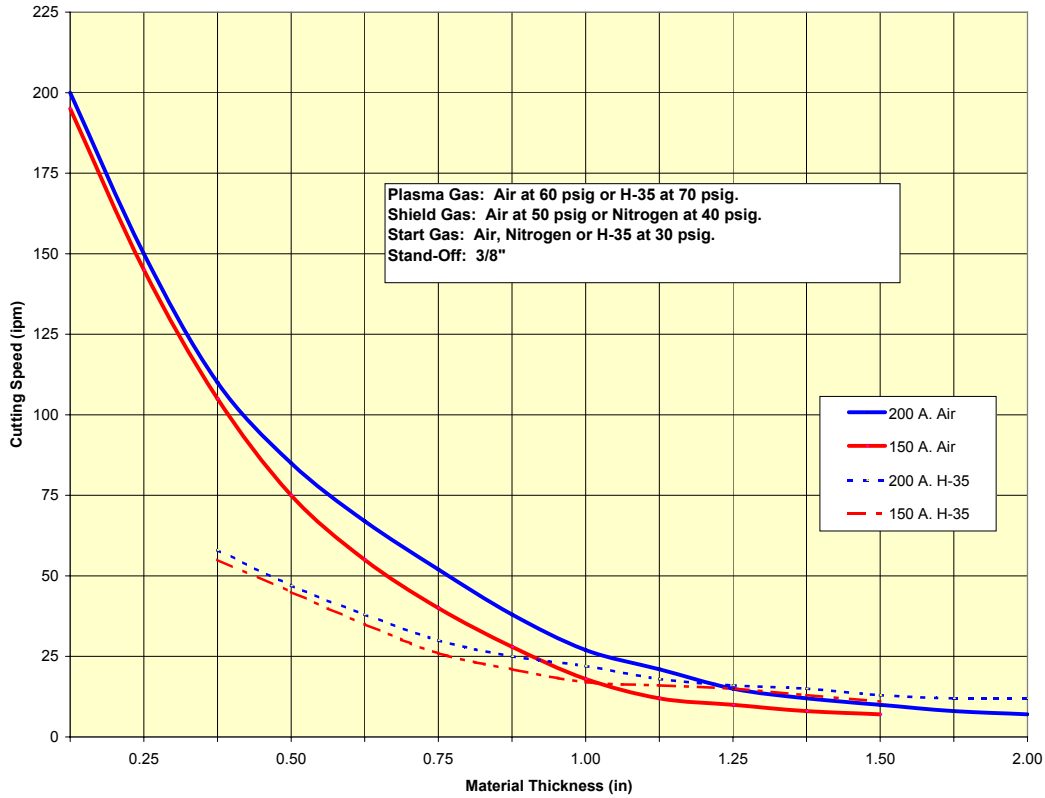

PT-26 300 Amp Stainless Steel

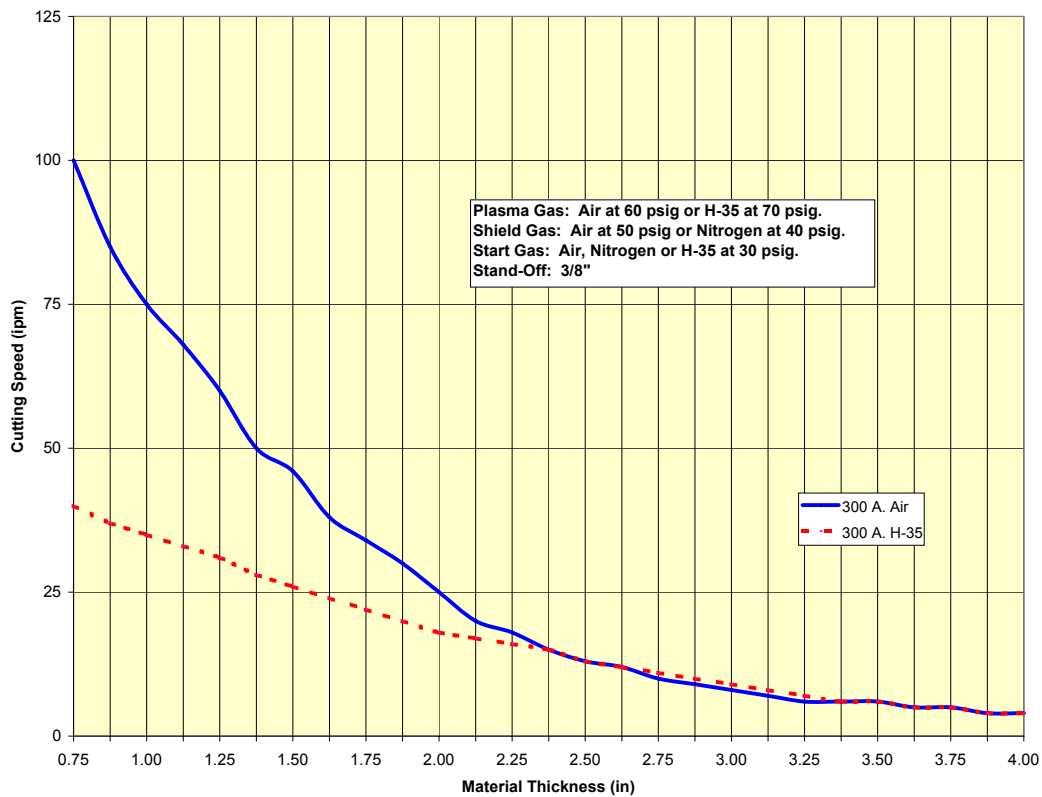

**WARNING**

Be sure that all primary power to the machine has been externally disconnected. Open wall disconnect switch or circuit breaker before attempting inspection or work inside of the power supply.

**WARNING**

Voltages in plasma cutting equipment are high enough to cause serious injury or possibly death. Be particularly careful around equipment when the covers are removed.

## 5.0 Maintenance

If this equipment does not operate properly, stop work immediately and investigate the cause of the malfunction. Maintenance work must be performed by an experienced person, and electrical work by a trained electrician. Do not permit untrained persons to inspect, clean, or repair this equipment. Use only recommended replacement parts.

### A. INSPECTION AND CLEANING

Frequent inspection and cleaning of the ESP-150 cutting machine is recommended. Some suggestions for inspecting and cleaning are as follows:

1. Check work cable to workpiece connection.
2. Check safety earth ground at workpiece and at power source chassis.
3. Check heat shield on torch. It should be replaced if damaged.
4. Check the torch electrode and cutting tip for wear on a daily basis. Remove spatter, replace if necessary.
5. Make sure cable and hoses are not damaged or kinked.
6. Make sure all plugs, fittings, and ground connection are tight.  
**CAUTION: Water occasionally accumulates in compressed air lines. Be sure to direct the first blast of air away from the equipment to avoid damage.**
7. With all input power disconnected, and wearing proper eye and face protection, blow out the inside of the cutting power supply using low-pressure dry compressed air.
8. Occasionally bleed water from the filter beneath the air regulators.

**CAUTION**

The coolant must be handled as chemical waste.

### B. FLOW TESTING

Improper flows can cause short life on the consumables, poor starting, bad cuts, or overheated torches. The flows given below are "cold" flow (no arc). To avoid fatal shock, follow the steps below to assure safe flow measurement.

1. Shut off input power at the main disconnect switch.
2. Lift the top lid of the ESP-150 and unplug the torch switch cord.
3. Close the lid.
4. Turn on the power at the main disconnect switch.
5. Place gas mode selector switch (OSS) in START/SHIELD position.
6. Place power ON-OFF switch (ROS) to ON.
7. Check flow measurements with flow measuring kit, P/N 19765.
8. Place mode selector switch (OSS) in CUT position and check CUT flow with flow measuring kit, P/N 19765.
9. Place ROS switch to OFF.
10. Turn off power at main disconnect switch.
11. Reconnect torch switch plug inside console.  
PT-26 Plasma Gas Flow (No Arc):  
Nitrogen or Air @ 60 psig: 110 cfh; H-35 @ 90 psig: 130 cfh  
PT-26 Start Gas Flow:  
Nitrogen or Air @ 40 psig: 75 cfh  
PT-26 Shield Gas Flow:  
Air or Nitrogen @ 85 psig: 200 cfh minimum.

**WARNING**

Voltages in plasma cutting equipment are high enough to cause serious injury or possibly death. Be particularly careful around equipment when the covers are removed.

**C. SPARK GAP ADJUSTMENT**

The spark gap, which is part of the high frequency generator, is factory set at 0.040-in. (+/- 0.002). After extended operation or if erratic operation is noted, it may be necessary to readjust or replace the electrodes. Use a feeler gauge when readjusting the gap. Cleaning or dressing of the spark gap electrodes is not recommended. When replacement is necessary, both electrodes should be replaced.

**D. TESTING AND REPLACING BRIDGE ASSEMBLY COMPONENTS**

The silicon diodes and SCR's used in the power supply are devices which allow current to flow in only one direction. They block current in the other direction. The diodes and SCR's are designed to provide long troublefree operation; however, should a failure occur, they may require replacement.

1. Testing Diodes
  - a. Locate the main rectifier assembly containing the silicon diodes and SCR's.
  - b. Electrically isolate main bridge rectifier assembly by disconnecting the main transformer secondary fuse links F1 and F2.
  - c. With ohmmeter on RX1 scale, place negative lead on the diode heat sink and touch positive lead to each pigtail terminal. Meter should read a low resistance of approximately 3 to 15 ohms on each diode.
  - d. Reverse leads and check each diode. All readings should show high resistance of 2 K (2000) ohms or higher. With most ohmmeters on the RX1 scale, 2K ohms is the highest possible reading available.
  - e. Since diode resistance is non-linear with voltage (using any scale), diodes are good when they show low resistance in one direction and high resistance in the opposite direction. They are bad when they show no or very low resistance in both directions (shorted), or if they show very high assistance in both directions (open).
2. Testing SCR's
  - a. Follow steps a. and b. under Testing Diodes. Disconnect the SCR pigtail.
  - b. With ohmmeter on RX1 scale place the negative lead on the anode (end of SCR with screw threads) and positive lead on the cathode (pigtail end). Meter should read a high resistance of 2 K (2000) ohms or higher.
  - c. Reverse leads and check each SCR. All readings again should show high resistance. When SCR's are bad they show low resistance in either direction.
  - d. Now check the gate circuit on the SCR's by placing the negative lead to the gate (wht wire off SCR) and the positive lead to the cathode. Meter should read approximately 20 ohms and should vary only slightly (5 ohms) when leads are reversed. If the meter reads zero or infinity in either direction the gate circuit is faulty and the SCR should be replaced.

**WARNING**

Be sure that all primary power to the machine has been externally disconnected. Open wall disconnect switch or circuit breaker before attempting inspection or work inside of the power supply.

**WARNING**

Voltages in plasma cutting equipment are high enough to cause serious injury or possibly death. Be particularly careful around equipment when the covers are removed.

**IMPORTANT:** When replacing Diodes or SCR's make sure mounting surfaces are clean. Coat mounting surfaces with Alcoa No. 2 EJC Electrical Joint Compound (no substitutes) available in 8 oz. bottles under P/N 73585980. Use a torque wrench to tighten diodes and SCR's. Recommended torques are 20-30 in.-lbs. for diodes; 125-150 in.-lbs. for SCR's.



## 5.1 Troubleshooting

Check the problem against the symptoms in the following troubleshooting guide. If the cause cannot be quickly located, shut off the input power, open up the unit, and perform a simple visual inspection of all the components and wiring. Check for components, bulged or leaking capacitors, or any other sign of damage or discoloration.

The cause of control malfunctions can also be found by referring to the sequence of operations and electrical schematic diagram and check out the various components. A volt-ohmmeter will be necessary for some of these checks.

*NOTE: Before checking voltages in the circuit, disconnect the power from the high frequency generator to avoid damaging your voltmeter.*

Be sure unit is set up properly for voltage being used and that the gas supplies are adequate.

### A. TROUBLESHOOTING GUIDE

- 1. Unit Inoperative; fan does not run.**
  - a. Check primary disconnect switch to make sure input power is being supplied.
  - b. Check links on the input terminal board TB to make sure all are connected to the proper input voltage being used. (See Form 14-376.)
  - c. Check for defective power switch (ROS).
- 2. No gas flow when torch switch is closed.**
  - a. Unplug torch switch plug and check for proper operation with an ohmmeter connected to pins 1 and 2 of torch switch plug.
  - b. Defective interlock switch (ISW).
  - c. Check for defective solenoid valves.
  - d. Plug (P1) may be loose at control board.
  - e. Defective logic board.
- 3. Pilot arc-high frequency sparks noted at spark gap but not at the torch.**
  - a. Check spark gap and readjust electrodes if necessary. Replace spark gap electrodes if worn beyond serviceability.
  - b. Check with an ohmmeter for continuity between torch nozzle and POS output where torch attaches to console.
- 4. No pilot arc-high frequency sparks noted at spark gap and at torch during preflow, but main contactor does not activate or chatters at end of 2 second preflow time.**
  - a. Check start gas pressure. It must be at least 30 psig.
  - b. Check cooling gas pressure (PT-26). It must be at least 50 psig.
  - c. If using PT-26 torch, check jumper plug between J1-5 and J1-4 on the torch switchplug.
  - d. Thermal switch in bridge, inductor, or main transformer may be open. Allow unit to cool down.
  - e. Defective logic board (675369).
- 5. No pilot arc - No spark noted in the spark gap.**
  - a. Check to see that pilot arc contactor (PAC) closes. If it does not, and gas flows when torch switch is closed, replace logic board.
  - b. If PAC closes, check for proper spark gap setting (0.040-in.).
  - c. Check the 120V input to the high voltage transformer (HFTR).
  - d. Check for arcing or carbon tracking around the spark gap.
  - e. If all of the above check good, HFTR is most likely defective.
- 6. Erratic pilot arc - pilot arc contactor (PAC) chatters.**
  - a. Defective logic board.
  - b. Power supply may be single phasing. Check main disconnect switch and fuses.

**7. No pilot arc - pilot arc contactor (PAC) drops out when main contactor (MC) activates at end of 2-second preflow.**

- a. Check for low open circuit voltage. It should be around 370 V at nominal line voltage.
- b. Check voltage between each side of resistor R29 and the WORK output connection when MC is activated. Place negative meter lead on side of resistor being checked and positive meter lead on the WORK output connection. The voltage on one side should be the open circuit voltage (370 V). The voltage on other side should be above 175 V. If lower voltage is under 175 V, PAC will drop out.
- c. Check the resistance of R29. It should be 133 K ohm.
- d. Disconnect R-29 resistor and measure the resistance from P1-1 to shunt (common). Resistance should be 200 K to 250 K ohms.
- e. Check for continuity between R29 and electrode (-) torch connections.
- f. With power off, mechanically pull in PAC. The resistance between POS and WORK connections should be 8 ohms.

**8. Main arc fails to transfer to work.**

- a. Make sure that work clamp is securely fastened to the work piece.
- b. Check for proper function of pilot arc (PT-26) and high frequency unit.
- c. Check main disconnect switch and fuses.
- d. Check main contactor (MC) by disconnecting primary power and check each contact for closure using an ohmmeter while physically pulling contactor.
- e. Check C24 and C24A capacitors (1900 uf, 450 V) with an ohmmeter. Resistance should be 900-1000 ohms with capacitor connected in the circuit. If shorted, replace capacitor. Then check R18 resistor. The resistance of R18 should be 5 ohms. The resistance between "DRB POS" and "CAP (+)" should be 25 ohms. If the stud mounted rectifier on D/R board is shorted, the 25 ohm will be less than 5 ohms even when meter probes are reversed.
- f. Check open circuit voltage. It should be about 370 volts.
- g. Check F1 and F2 fuses. The open circuit can still be 370 volts with one blown fuse.
- h. Current control board (674935) may be defective.

**9. Short tip life.**

- a. Check for correct gas pressure.
- b. Check gas flow rate using flowmeter (P/N 19765).
- c. Check to see if pilot arc contactor (PAC) remains activated after main arc transfers. This can be done by observing the spark in the spark gap of the high freq. unit. The high freq. spark should shut off as soon as main arc starts. If spark continues after main arc is established, either main contactor (MC) or logic board is defective.
- d. Arc current is set too high.
- e. Wrong cutting tip size. Use larger tip.
- f. Defective current control board.

**10. Pilot arc cycles on and off when torch switch is not depressed.**

- a. Unplug torch switch plug. If cycling stops, then torch switch wires or plug or torch switch itself are shorted.
- b. Defective logic board.

**11. No or limited control of output current.**

- a. Defective current control potentiometer (CCP). Check by placing negative meter lead on WORK output connection and positive meter lead on current control board P1-2. (P1 is the larger of the two plugs.) With the fan running (machine at idle), adjust CCP from min. to max. They read zero at min. (1.1 volts on ESP-150); 10 Volts DC at max. The meter should move smoothly from zero to 10 V as CCP is rotated from min. to max.
- b. Defective logic board.

**12. Gas does not shut off after 10 seconds of preflow.**

- a. Turn off ready-off switch (ROS). If gas continues to flow, solenoid valve is defective.
- b. Defective logic board.

**13. No arc.**

Check that the mains power supply switch is turned on. Check that the welding current supply and return cables are correctly connected. Check that the correct current value is set.

**14. The welding current is interrupted during welding.**

Check whether the thermal overload trip has operated (indicated by the lamp on the front panel). Check the mains power supply fuses.

**15. The thermal cut-out trips frequently.**

Make sure that you are not exceeding the rated data for the power source (i.e. that the unit is not being overloaded).

**16. Poor welding performance.**

Check that the welding current supply and return cables are correctly connected. Check that the correct current value is set. Check that the correct electrode is being used. Check the mains power supply fuses.

**B. SEQUENCE OF OPERATION**

1. Close primary disconnect switch.
  - a. Power supplied to unit.
2. Place Power Switch (ROS) to "Ready" position.
  - a. Fan motor (FM) and Pump motor on.
  - b. Low Gas LED on.
  - c. Control circuit energizes.
3. Place Gas Mode Switch (OSS) to "CUT" position.
  - a. Gas solenoid valves (CGSV) energize. Gases flow to permit setting of pressures and to purge system.
4. Place OSS to "Operate" position.
  - a. Gas valves (PGSV and CGSV) deenergize to stop gas flows.
5. Depress torch switch.
  - a. SHSV and SGSV (shield and start) gas solenoid valves open to allow gases to flow to torch.
  - b. Pilot Arc Contactor (PAC) closes.
  - c. High Frequency (HF) energizes.
  - d. Pressure Switches (PGPS & CGPS) close (provided gas pressures are set above 19 psig on PGPS and 22 psig on CGPS).
  - e. Two seconds later, Main Contactor (MC) closes to establish pilot arc.
  - f. Pilot arc will transfer to cutting arc within 6 seconds as long as torch is close enough (1/8" — 1/4") to work.
  - g. HF and PAC deenergizes immediately when cutting arc is established, or after 6 seconds of continuous pilot arc. If cutting arc is not established after six seconds, MC will open but the HF will remain energized. MC and pilot arc will then cycle on and off every 3 seconds, MC will open but the HF will remain energized. MC and pilot arc will then cycle on and off every 3 seconds until torch switch is released.

**WARNING**

**DANGEROUS HIGH VOLTAGE (OVER 300 VOLTS) EXISTS AT THE TORCH FRONT END WHENEVER MC IS CLOSED; THEREFORE, RELEASE TORCH SWITCH WHEN CUTTING IS NOT ESTABLISHED AND REPEAT STEP 5.**

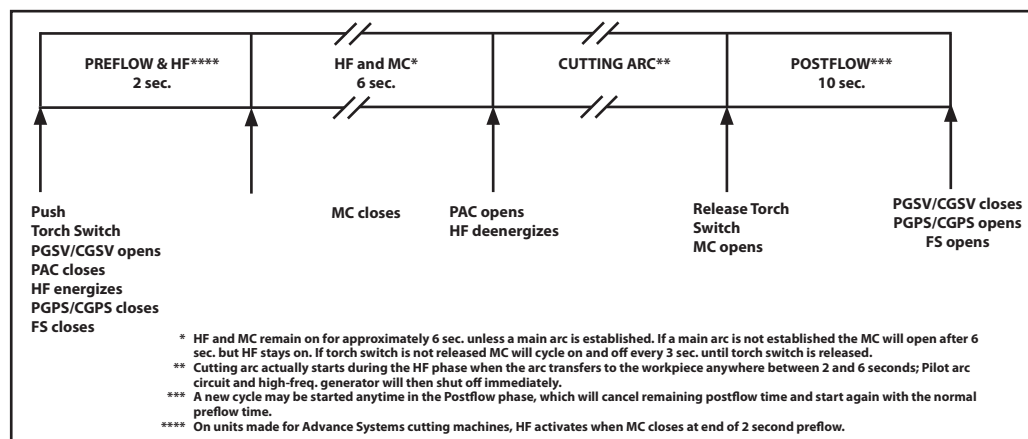

**Fig. 22 - Torch Operation Sequence Diagram**

6. Release torch switch.
  - a. MC opens and the cutting arc shuts off.
  - b. Gases continue to flow (postflow) for approximately another 10 seconds at which time the PGSV and CGSV will close, opening PCPS and CGPS.

*NOTE: A new cutting cycle can be started anytime during the postflow. As soon as the torch switch is depressed, the remaining postflow time will cancel and the normal preflow time will start.*

7. Control circuit will not energize or can deenergize during a cutting cycle when:
  - a. PGPS or CGPS is open due to insufficient gas pressure (at least 15 psi required).
  - b. Thermal Switches (TS) are open due to overheating of unit. TS should open at 180° C (356° F).
8. Place ROS to "OFF" position.
  - a. Control circuit deenergizes.
  - b. Fan motor (FM) deenergizes.
  - c. Low Gas light on status board will go out.
9. Open primary disconnect switch.
  - a. Input power unit shut off.

C. STATUS LIGHT TROUBLESHOOTING CHART

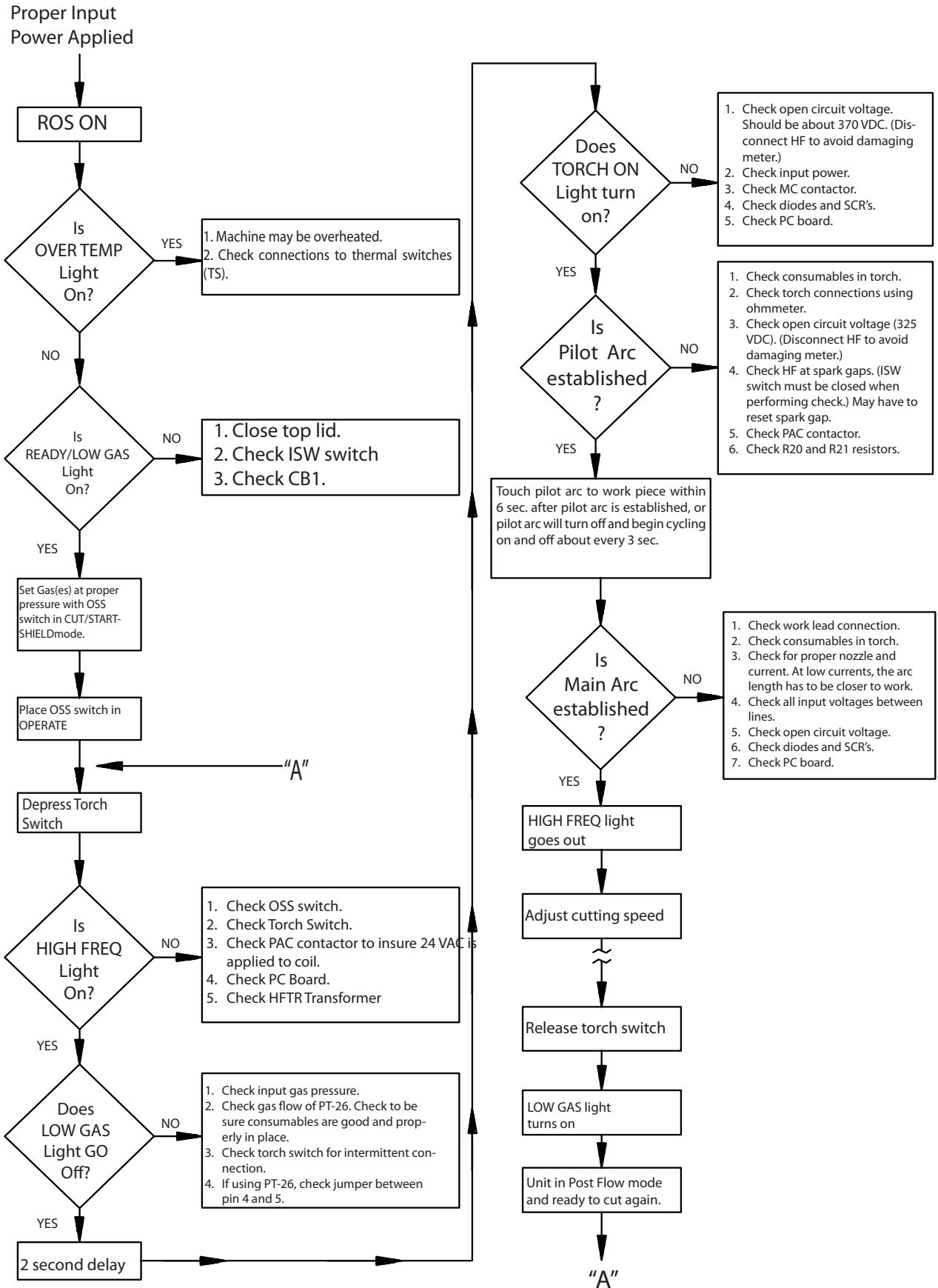



## **6.0 Replacement Parts**

### **6.1 General**

Always provide the serial number of the unit on which the parts will be used. The serial number is stamped on the unit nameplate.

### **6.2 Ordering**

To ensure proper operation, it is recommended that only genuine ESAB parts and products be used with this equipment. The use of non-ESAB parts may void your warranty.

Replacement parts may be ordered from your ESAB Distributor.

Be sure to indicate any special shipping instructions when ordering replacement parts.

Refer to the Communications Guide located on the back page of this manual for a list of customer service phone numbers.

The ESP-150 is designed and tested in accordance with the international and European standards EN 60974-1 and EN 60974-10. It is the obligation of the service unit which has carried out the service or repair work to make sure that the product still conforms to the said standard. Repair and electrical work should be performed by an authorized ESAB serviceman. Use only ESAB original spare and wear parts. Spare parts may be ordered through your nearest ESAB dealer, see the last page of this publication.

### **NOTE:**



Bill of Material item numbers enclosed by a square denote sub-assemblies. Refer to Bill of Material to identify items that make up the sub-assembly. Sub-assemblies may be ordered instead of ordering each item individually.

### **Note**

Schematics and Wiring Diagrams are printed on 279.4mm x 431.8mm (11" x 17") paper and are included inside the back cover of this manual.

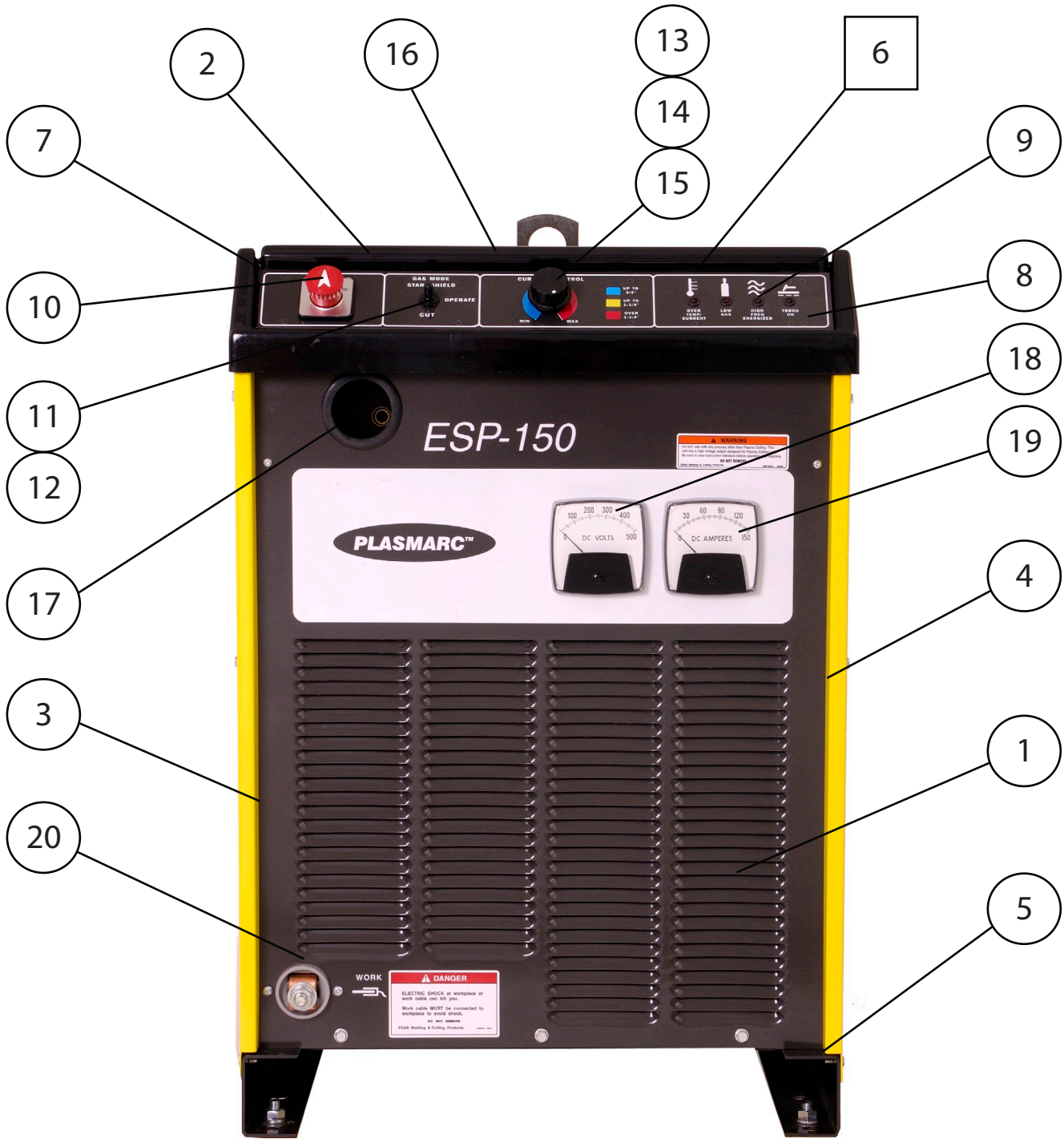



**SECTION 6****REPLACEMENT PARTS**

| <b>ITEM</b> | <b>QTY</b> | <b>PART NO</b> | <b>DESCRIPTION</b>                                   | <b>SYMBOL</b> |
|-------------|------------|----------------|--|---------------|
| 1           | 1          | 0558002680M    | PANEL FRONT  |               |
| 2           | 1          | 0558002683Y    | PANEL TOP  |               |
| 3           | 1          | 0558002681Y    | PANEL SIDE LEFT                                      |               |
| 4           | 1          | 0558002682Y    | PANEL SIDE RIGHT                                     |               |
| 5           | 1          | 0558002678M    | PANEL BASE   |               |
| 6           | 1          | 0558002806     | CONTROL PANEL TOP ASSY<br>(Includes Items 7 thru 10) |               |
| 7           | 1          | 680718         | CONTROL PANEL TOP SHELL                              |               |
| 8           | 1          | 0558003773     | PANEL CONTROL SILKSCREENED                           |               |
| 9           | 1          | 0558003775     | PC BOARD - STATUS LIGHTS                             | SLBD          |
| 10          | 1          | 0558003780     | SWITCH ROTOR DPST 600V 25A                           | ROS           |
| 11          | 1          | 0558004052     | SWITCH TOGGLE 3 POS DPDT 15A 125V                    | OSS           |
| 12          | 1          | 951474         | SEAL SWITCH BLACK                                    |               |
| 13          | 1          | 0558003776     | POTENTIOMETER 15K 2W                                 | CCP           |
| 14          | 1          | 673999         | POTENTIOMETER SHAFT LOCK                             |               |
| 15          | 1          | 0558003777     | KNOB   |               |
| 16          | 1          | 0558003778     | MAT RUBBER   |               |
| 17          | 1          | 0558004053     | GROMMET RUBBER                                       |               |
| 18          | 1          | 0558003772     | VOLTMETER DC (0-500 VOLTS)                           | VM            |
| 19          | 1          | 0558003769     | AMMETER DC (0-150 AMPS)                              | AM            |
| 20          | 1          | 0558004054     | TERMINAL OUTPUT ASSY                                 | WORK          |

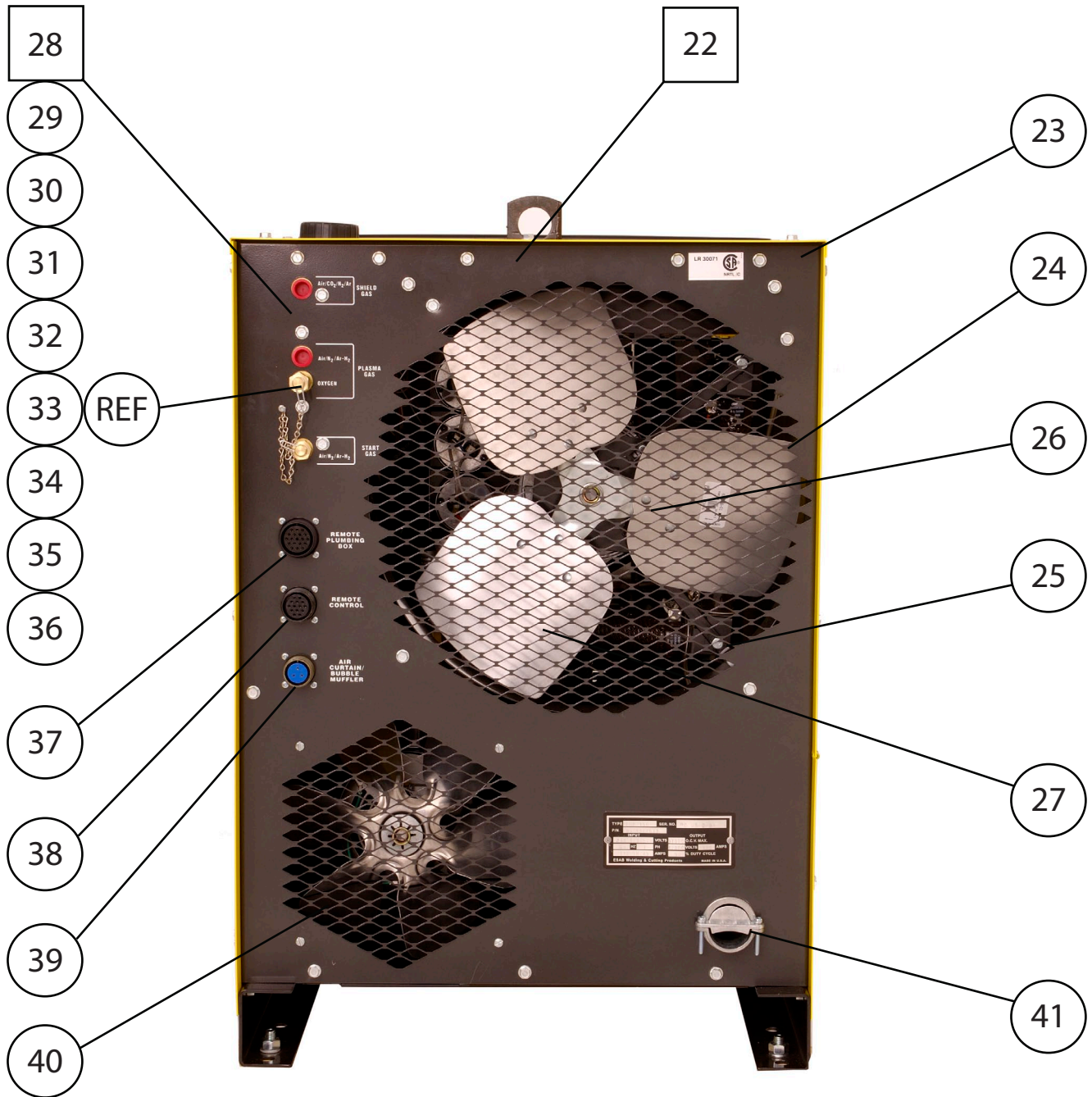

**SECTION 6****REPLACEMENT PARTS**

| ITEM | QTY | PART NO     | DESCRIPTION  | SYMBOL          |
|------|-----|-------------|--|-----------------|
| 22   | 1   | 0558002800M | PANEL REAR ASSY<br>(Includes Items 23 thru 41)           |                 |
| 23   | 1   | 0558002679M | PANEL REAR   |                 |
| 24   | 1   | 0558004077  | SHROUD MACHINE FAN 16"                                   |                 |
| 25   | 1   | 0558004055  | BLADE MACHINE FAN 16"                                    |                 |
| 26   | 1   | 0558000749  | MOTOR MACHINE FAN 1/3 HP                                 | FM              |
| 27   | 4   | 17300008    | RESISTOR 8 OHM 300W                                      | R20,R21,R30,R31 |
| 28   | 1   | 0558002810  | MANIFOLD GAS CONTROL ASSY<br>(Includes Items 29 thru 36) |                 |
| 29   | 3   | 0558006864  | VALVE SOLENOID 165 PSI 24VAC                             | SV-1,2,3        |
| 30   | 1   | 0558002345  | SWITCH PRESSURE 17 PSI                                   | PS1             |
| 31   | 1   | 0558006291  | ELBOW STREET 90 DEGREE 1/8NPT                            |                 |
| 32   | 1   | 0558002346  | SWITCH PRESSURE 22 PSI                                   | PS2             |
| 33   | 1   | 0558004058  | CONNECTION RH OXYGEN B SIZE                              |                 |
| 34   | 2   | 0558006292  | ELBOW STREET 90 DEGREE 1/4NPT                            |                 |
| 35   | 1   | 0558004057  | ADAPTOR RH B/I-G*F 1/4NPTM                               |                 |
| 36   | 1   | 10Z30       | ADAPTOR RH B/A-W*M 1/4NPTM                               |                 |
| 37   | 1   | 0558004059  | RECEPTACLE PANEL 19 SOCKET                               | J1              |
| 38   | 1   | 0558004060  | RECEPTACLE PANEL 14 SOCKET                               | J2              |
| 39   | 1   | 0558004061  | RECEPTACLE PANEL 3 SOCKET                                | J3              |
| 40   | 1   | 0558002820M | SHROUD COOLANT PUMP FAN 10.5"                            |                 |
| 41   | 1   | 0558004079  | STRAIN RELIEF 2"   |                 |
| Ref  | Ref | 0558004056  | CONNECTION LH FUEL GAS B SIZE                            |                 |

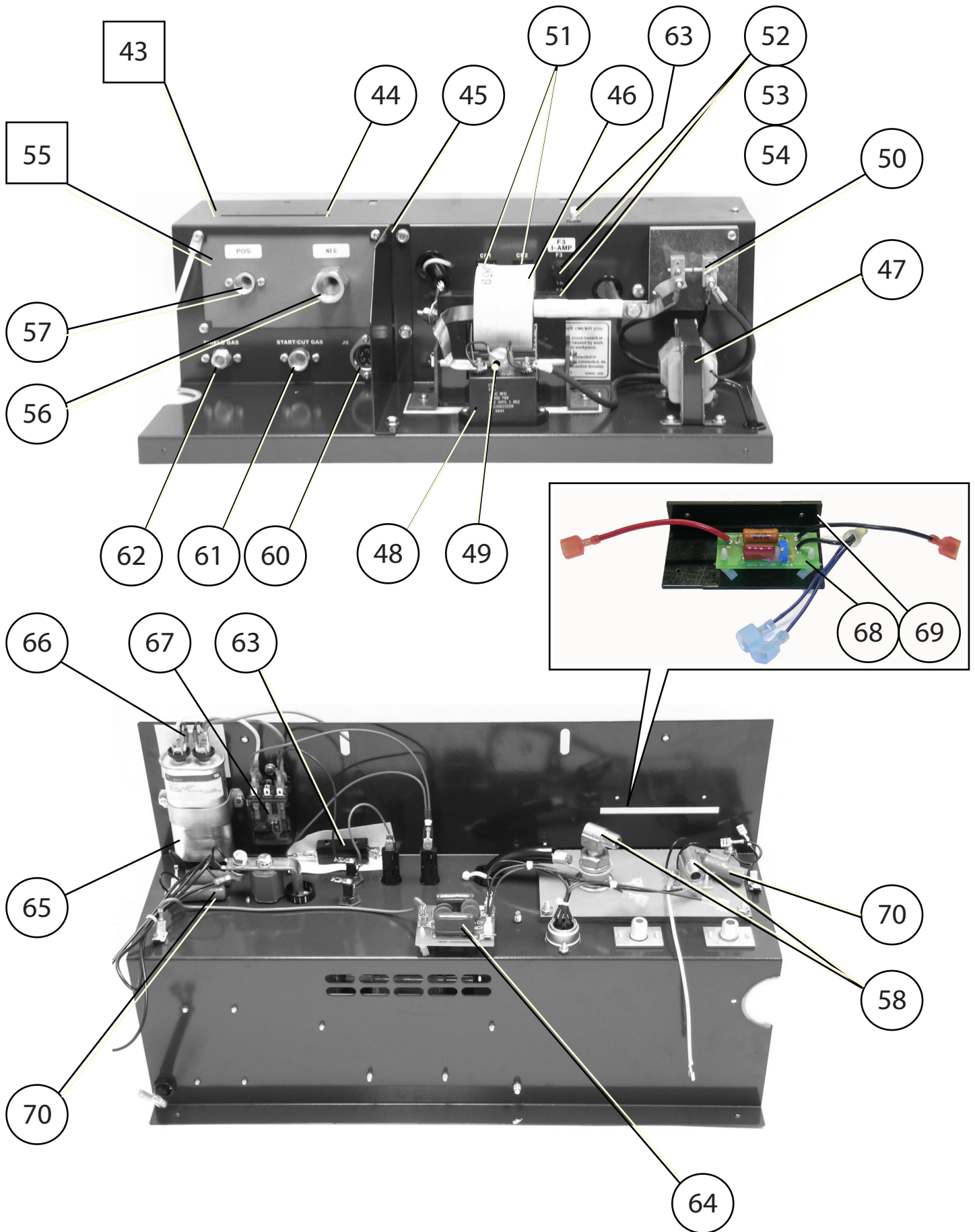

**SECTION 6****REPLACEMENT PARTS**

| ITEM | QTY | PART NO     | DESCRIPTION  | SYMBOL          |
|------|-----|-------------|--|-----------------|
| 43   | 1   | 0558002803  | HIGH FREQUENCY ASSY<br>(Includes Items 44 thru 70)         |                 |
| 44   | 1   | 0558002804M | PANEL HIGH FREQUENCY ASSY                                  |                 |
| 45   | 1   | 30845M      | PANEL DIVIDER  |                 |
| 46   | 1   | 30859       | AUTOTRANSFORMER HIGH FREQUENCY                             | HFATR           |
| 47   | 1   | 0558007469  | TRANSFORMER HIGH FREQUENCY                                 | HFTR            |
| 48   | 1   | 0558007163  | CAPACITOR .002uF 10KWV                                     | C18A            |
| 49   | 1   | 0558007470  | CAPACITOR 2500pF 15KV                                      | C18B            |
| 50   | 1   | 677905      | SPARK GAP ASSY   | SG              |
| 51   | 2   | 2062161     | CIRCUIT BREAKER 5A   | CB1,2           |
| 52   | 2   | 182W15      | FUSE HOLDER  |                 |
| 53   | 1   | 82W43       | FUSE 1A 250V   | F3              |
| 54   | 1   | 96W22       | FUSE SLO-BLO 3.2A 250V                                     | F4              |
| 55   | 1   | 30813       | TORCH CONNECTION PANEL ASSY<br>(Includes Items 56 thru 58) |                 |
| 56   | 1   | 634090      | ADAPTOR SPECIAL  |                 |
| 57   | 1   | 58V75       | ADAPTOR BULKHEAD LH B/A-W*F<br>1/4NPTM                     |                 |
| 58   | 2   | 0558006292  | ELBOW STREET 90 DEGREE 1/4NPT                              |                 |
| 59   |     |             | Not Used   |                 |
| 60   | 1   | 997830      | RECEPTACLE 5 POLE  | J6              |
| 61   | 1   | 58V58       | ADAPTOR BULKHEAD B/I-G*F 1/4NPTM                           |                 |
| 62   | 1   | 33033       | ADAPTOR BULKHEAD B/A-W*M<br>1/4NPTM                        |                 |
| 63   | 1   | 674592      | SWITCH SNAP ACTION SPDT 15A 125V                           | ISW             |
| 64   | 1   | 674971      | PC BOARD - HF FILTER                                       | FBD2            |
| 65   | 1   | 0558004069  | CAPACITOR 10uF 370VDC                                      | C34             |
| 66   | 1   | 0558004071  | RESISTOR 220K OHM 1W                                       | R23             |
| 67   | 1   | 0558004088  | RELAY 3PDT 240VAC 28VDC 10A                                | GFIR            |
| 68   | 1   | 56997963    | PC BOARD - VOLTAGE DIVIDER                                 |                 |
| 69   | 1   | 0558002996  | BRACKET VDR  |                 |
| 70   | 4   | 950972      | CAPACITOR .022uF 1600VDC                                   | C15,C16,C20,C21 |

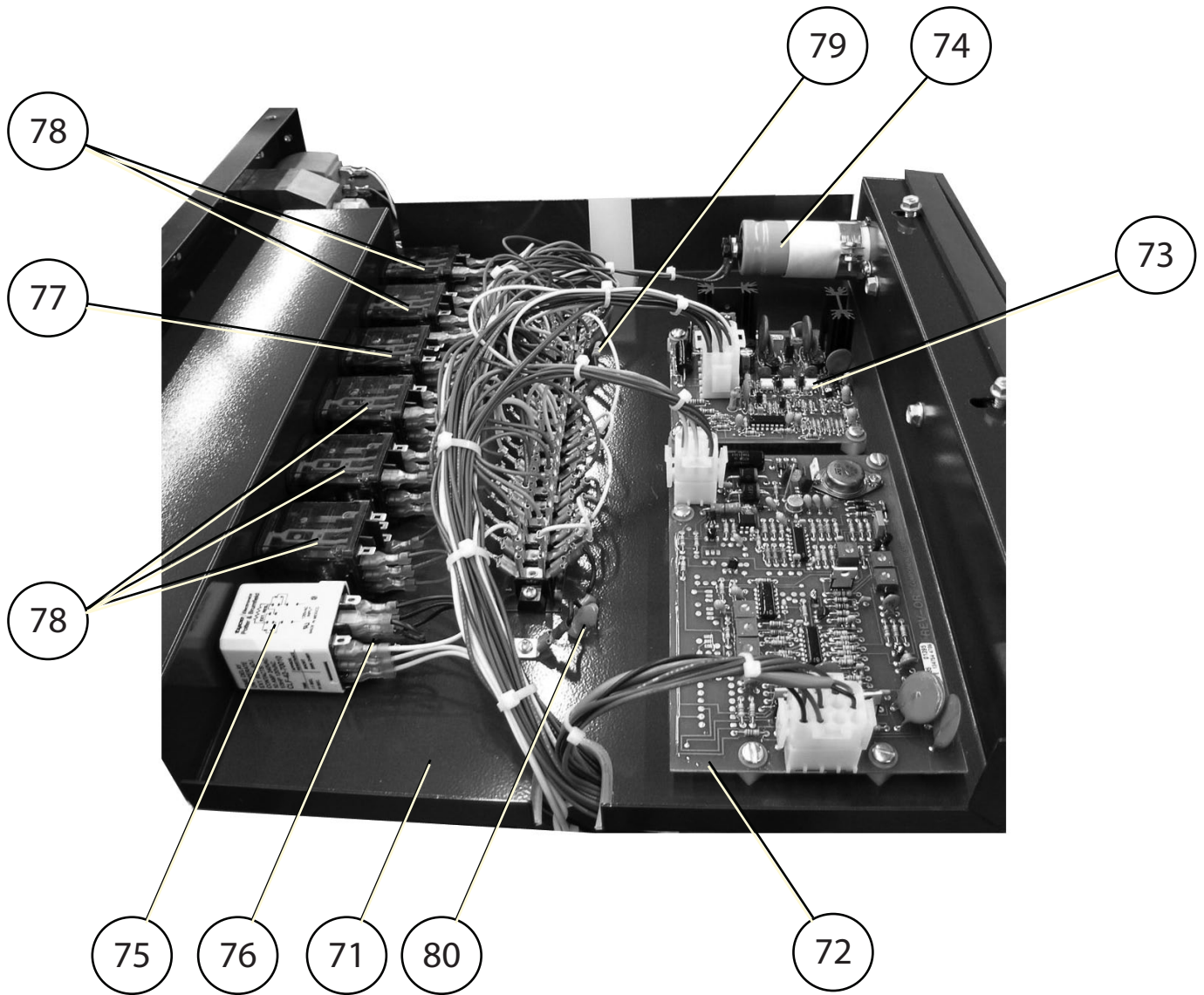

| <b>ITEM</b> | <b>QTY</b> | <b>PART NO</b> | <b>DESCRIPTION</b>               | <b>SYMBOL</b>       |
|-------------|------------|----------------|----------------------------------|---------------------|
| 71          | 1          | 0558002689M    | BOX PC BOARD                     |                     |
| 72          | 1          | 0558004085     | PC BOARD - CONTROL               | CBD                 |
| 73          | 1          | 0558004086     | PC BOARD - LOGIC                 | LBD                 |
| 74          | 1          | 0558004087     | CAPACITOR 1500uF 50VDC           | C25                 |
| 75          | 1          | 0558004090     | RELAY TIME DELAY DPDT 120VAC 10A | TDR                 |
| 76          | 1          | 17111220       | RESISTOR 2K OHM 0.25W            | R50                 |
| 77          | 1          | 0558004088     | RELAY 3PDT 240VAC 28VDC 10A      | PFR                 |
| 78          | 5          | 0558004089     | RELAY DPDT 24VAC 10A             | SCSR,OSR,CDR,ACR,FR |
| 79          | 1          | 17140310       | RESISTOR 10K OHM 2W              | R28                 |
| 80          | 1          | 0558004068     | CAPACITOR .01uF 250VAC           | C13                 |

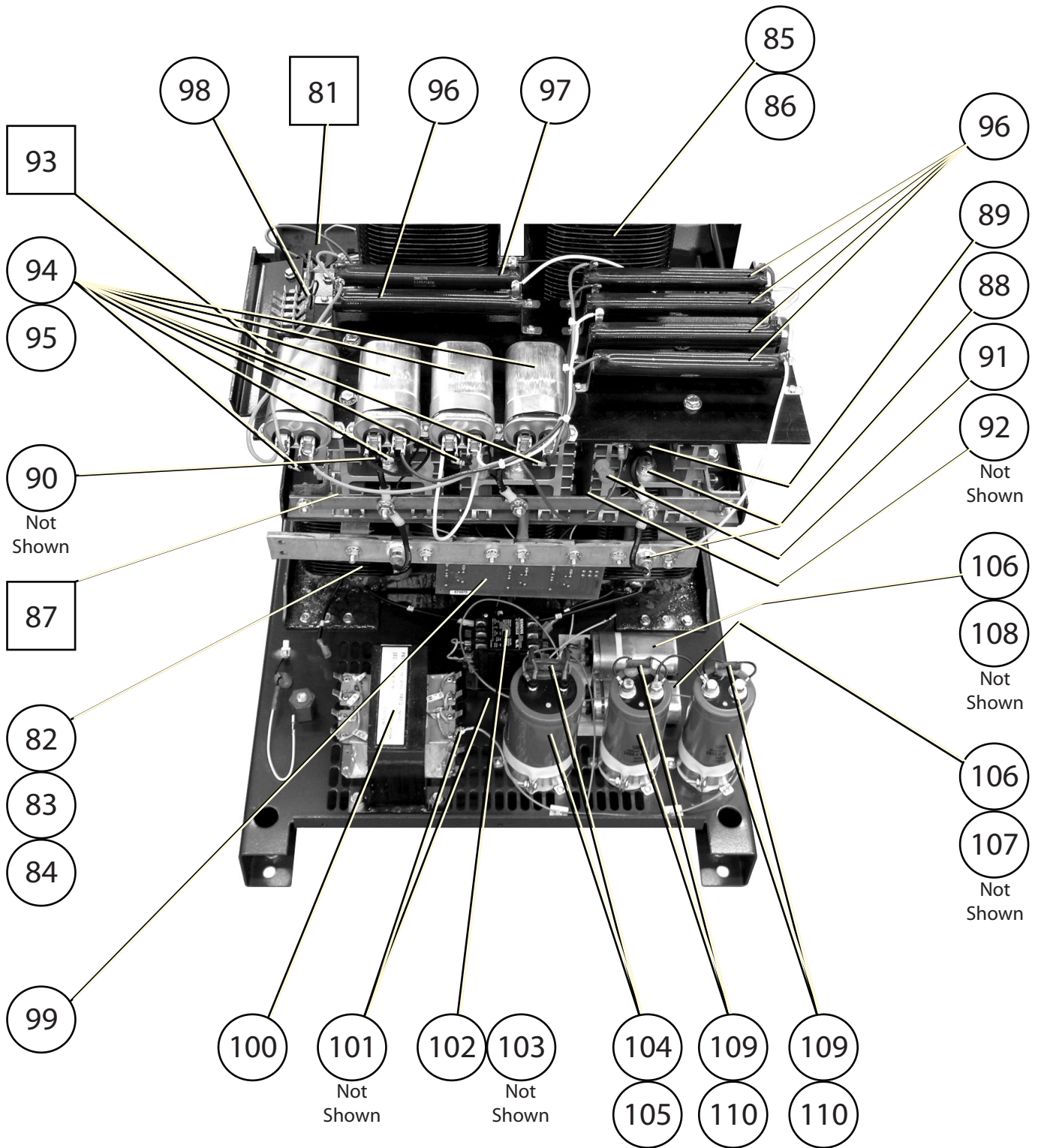



**SECTION 6****REPLACEMENT PARTS**

| ITEM | QTY | PART NO    | DESCRIPTION  | SYMBOL              |
|------|-----|------------|--|---------------------|
| 81   | 1   | 0558006906 | TRANSFORMER / BRIDGE ASSY<br>(Includes Items 82 thru 99) |                     |
| 82   | 1   | 0558004076 | TRANSFORMER MAIN<br>(Includes Items 83 and 84)           | MTR                 |
| 83   | 2   | 0558004084 | FUSE LINK 150A 250V                                      | F1,2                |
| 84   | 3   | 0558004075 | SWITCH THERMAL 180C                                      | MTRTS1,2,3          |
| 85   | 1   | 0558004074 | INDUCTOR<br>(Includes Item 86)                           | IND                 |
| 86   | 1   | 0558004075 | SWITCH THERMAL 180C                                      | INDTS1              |
| 87   | 1   | 680379     | BRIDGE ASSY<br>(Includes Items 88 thru 92)               | BR                  |
| 88   | 5   | 950703     | DIODE FORWARD 1200V 85A                                  | D1,D2,D3,D4,D4A     |
| 89   | 3   | 680452     | RECTIFIER SILICON CONTROLLED 1200V                       | SCR1,2,3            |
| 90   | 1   | 950711     | SWITCH THERMAL 194F                                      | BRTS1               |
| 91   | 3   | 0558004068 | CAPACITOR .01uF 250VAC                                   | C31,32,33           |
| 92   | 3   | 950065     | VARISTOR METAL OXIDE 420VAC 160J                         | MOV1,2,3            |
| 93   | 1   | 0558004073 | FILTER NETWORK ASSY<br>(Includes Items 94 thru 98)       |                     |
| 94   | 4   | 0558004069 | CAPACITOR 10uF 370VDC                                    | C10,C11,C12,C14     |
| 95   | 4   | 0558004071 | RESISTOR 220K OHM 1W                                     | R10,R11,R12,R17     |
| 96   | 5   | 17280010   | RESISTOR 10 OHM 100W                                     | R13,R14,R15,R16,R18 |
| 97   | 1   | 17280210   | RESISTOR 1K OHM 100W                                     | R19                 |
| 98   | 1   | 17145410   | RESISTOR 100K OHM 2W                                     | R32                 |
| 99   | 1   | 674970     | PC BOARD - SCR GATE FILTER                               | FBD1                |
| 100  | 1   | 680381     | TRANSFORMER CONTROL                                      | CTR                 |
| 101  | 3   | 0558004068 | CAPACITOR .01uF 250VAC                                   | C26,C29,C30         |
| 102  | 1   | 0558010711 | CONTACTOR PILOT ARC 40A 24VAC                            | PAC                 |
| 103  | 1   | 0558004070 | RESISTOR 470 OHM 2W                                      | R26                 |
| 104  | 1   | 950627     | CAPACITOR 4200uF 350VDC                                  | C35                 |
| 105  | 1   | 17315247   | RESISTOR 4.7K OHM 12W                                    | R6                  |
| 106  | 2   | 0558004069 | CAPACITOR 10uF 370VDC                                    | C17,C19             |
| 107  | 2   | 0558004068 | CAPACITOR .01uF 250VAC                                   | C27,28              |
| 108  | 1   | 17145422   | RESISTOR 220K OHM 2W                                     | R22                 |
| 109  | 2   | 0558000447 | CAPACITOR 1900uF 450VDC                                  | C24,24A             |
| 110  | 2   | 17225310   | RESISTOR 10 OHM 8W                                       | R36,37              |

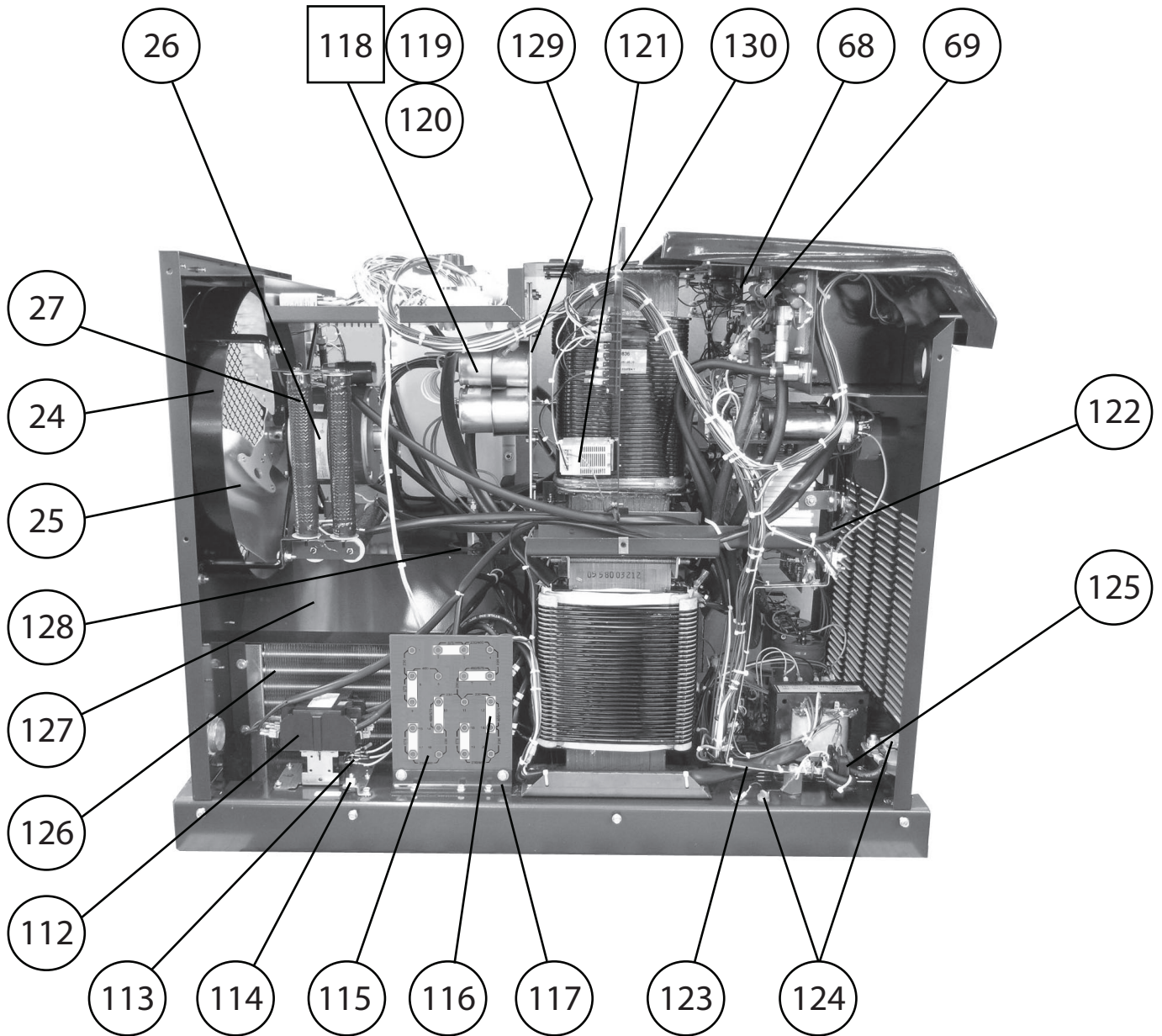

**SECTION 6****REPLACEMENT PARTS**

| <b>ITEM</b> | <b>QTY</b> | <b>PART NO</b> | <b>DESCRIPTION</b>                                      | <b>SYMBOL</b> |
|-------------|------------|----------------|---|---------------|
| 112         | 1          | 0558010710     | CONTACTOR MAIN 90A 24VAC                                | MC            |
| 113         | 1          | 0558004070     | RESISTOR 470 OHM 2W                                     | R25           |
| 114         | 1          | 0558004081     | LUG GROUNDING   | GND1          |
| 115         | 1          | 9680911        | TERMINAL BOARD ASSY 230/460/575V<br>(Includes Item 116) | TB            |
| 116         | 10         | 672065         | TERMINAL STRAP  |               |
| 117         | 1          | 672227M        | BRACKET MOUNTING TERMINAL BOARD                         |               |
| 118         | 1          | 30941          | CAPACITOR BANK ASSY<br>(Includes Items 119 and 120)     |               |
| 119         | 9          | 0558004066     | CAPACITOR 60uF 370VDC                                   | C1-C9         |
| 120         | 9          | 0558004067     | RESISTOR 330K OHM 0.5W                                  | R1-R9         |
| 121         | 1          | 0558003760     | MODULE POWER SUPPLY 24V                                 |               |
| 122         | 1          | 17175413       | RESISTOR 133K OHM 2W (In-line / Violet Wire)            | R29           |
| 123         | 1          | 0558004072     | SHUNT ASSY  | SH            |
| 124         | 1          | 0558004068     | CAPACITOR .01uF 250VAC                                  | C22,23        |
| 125         | 1          | 0458918880     | REED SWITCH   | RSW           |
| 126         | 1          | 0558000292     | HEAT EXCHANGER  |               |
| 127         | 1          | 0558002686M    | PANEL TOP AIR EXIT CHAMBER                              |               |
| 128         | 1          | 186W91         | GROMMET RUBBER 2-5/8" I.D.                              |               |
| 129         | 1          | 0558002688     | PLATE MOUNTING CAPACITOR BANK ASSY                      |               |
| 130         | 1          | 0558002808M    | BAFFLE LEFT   |               |

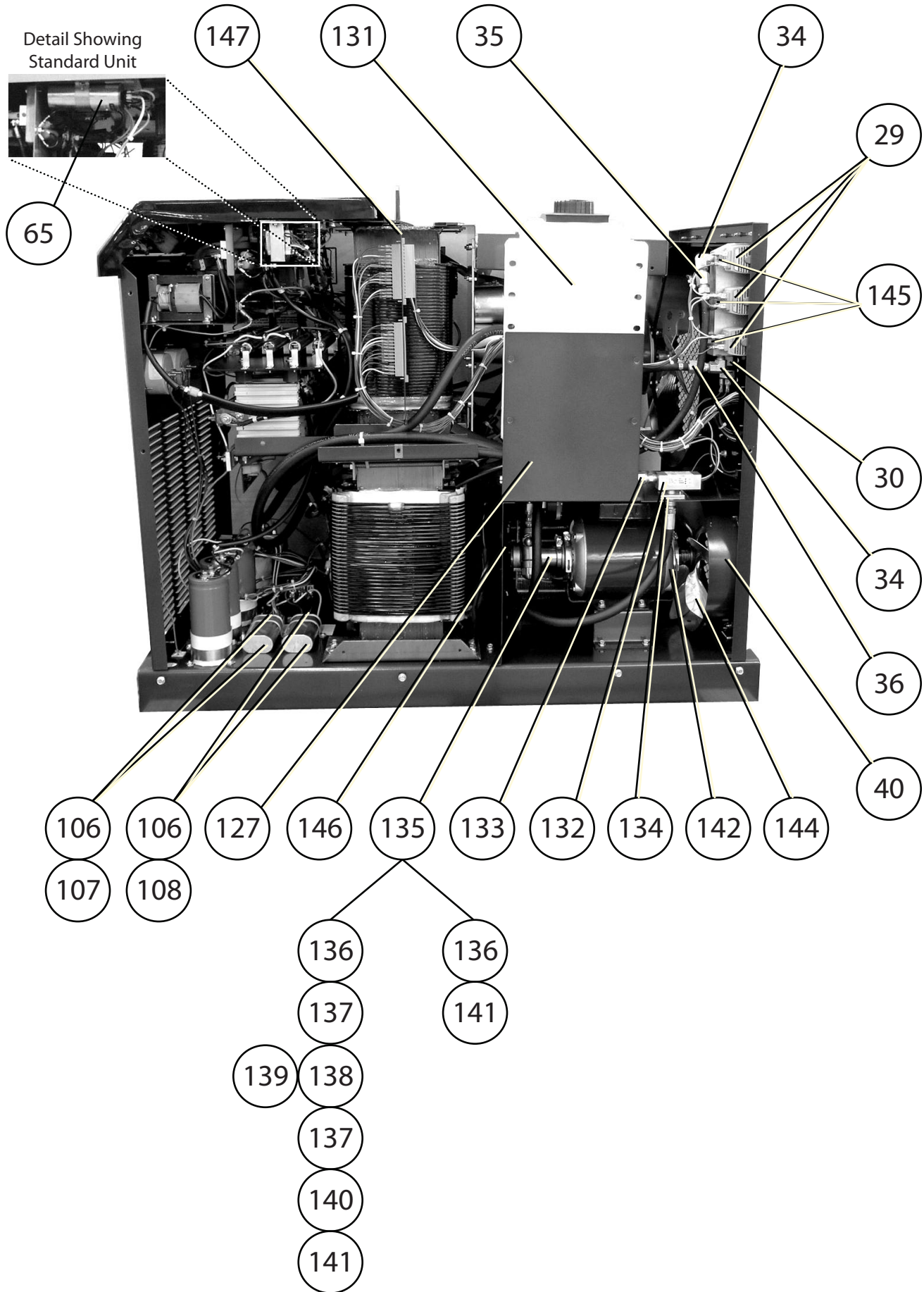

**SECTION 6****REPLACEMENT PARTS**

| <b>ITEM</b> | <b>QTY</b> | <b>PART NO</b> | <b>DESCRIPTION</b>                  | <b>SYMBOL</b> |
|-------------|------------|----------------|-------------------------------------|---------------|
| 131         | 1          | 0558004065     | TANK COOLANT 6 QUART                |               |
| 132         | 1          | 0558004064     | SWITCH FLOW 0.25GPM                 |               |
| 133         | 1          | 10Z30          | ADAPTOR RH B/A-W*M 1/4NPTM          |               |
| 134         | 1          | 58V75          | ADAPTOR BULKHEAD LH B/A-W*F 1/4NPTM |               |
| 135         | 1          | 0558004062     | PUMP COOLANT 60PSI 96GPH            |               |
| 136         | 2          | 0558006272     | ADAPTOR BUSHING 1/4NPTF 3/8NPTM     |               |
| 137         | 2          | 67101075       | NIPPLE 1/4NPT                       |               |
| 138         | 1          | 461107         | TEE STREET 1/4NPT                   |               |
| 139         | 1          | 598481         | GAGE PRESSURE 200PSI 1400KPa        |               |
| 140         | 1          | 21124          | CHECK VALVE                         |               |
| 141         | 2          | 10Z30          | ADAPTOR RH B/A-W*M 1/4NPTM          |               |
| 142         | 1          | 0558004063     | MOTOR COOLANT PUMP 1/3 HP           | PM            |
| 143         | 1          | 0558002685M    | BRACKET MOUNTING COOLANT PUMP MOTOR |               |
| 144         | 1          | 0558002901     | BLADE COOLANT PUMP MOTOR 9.75"      |               |
| 145         | 3          | 0558004070     | RESISTOR 470 OHM 2W                 | R51,52,53     |
| 146         | 1          | 0558002687M    | PANEL SIDE AIR EXIT CHAMBER         |               |
| 147         | 1          | 0558002807M    | BAFFLE RIGHT                        |               |



---

## NOTES

---

---

## NOTES

---



---

## REVISION HISTORY

---

1. Revision "C" - 07/2004 - Revised with updated schematic diagrams. Made various editorial changes also.
2. Revision "C" - 08/2006 - Replacement parts section, front view, changed item 11 from: p/n 950812 to: 636702.
3. Revision "D" - 02/2007 - updated / replaced Replacement Parts section.
4. Revision "E" - 06/2008 - updated P45 / J5 location functions in Section 3.
5. Revision "F" - 06/2010 - updated Replacement Parts section with VDR board and bracket info & updated schem pack. Added VDR adjustment info in INSTALLATION section.
6. Revision "F" - 11/2010 - Updated schematic pack per DNECO # 103119.
7. Revision "F" - 08/2012 - Updated contactor BOM p/n's for J. Magee.
8. Revision "F" - 08/2014 - Removed "7" prefix from BOM item 50.
9. Revision "H" - 02/2015 - Updated cut data section.

**ESAB Welding & Cutting Products, Florence, SC  
COMMUNICATION GUIDE - CUSTOMER SERVICES**

- A. CUSTOMER SERVICE QUESTIONS:  
Telephone: (800)362-7080 / Fax: (800) 634-7548 Hours: 8:00 AM to 7:00 PM EST  
Order Entry Product Availability Pricing Order Information Returns
- B. ENGINEERING SERVICE:  
Telephone: (843) 664-4416 / Fax : (800) 446-5693 Hours: 7:30 AM to 5:00 PM EST  
Warranty Returns Authorized Repair Stations Welding Equipment Troubleshooting
- C. TECHNICAL SERVICE:  
Telephone: (800) ESAB-123/ Fax: (843) 664-4452 Hours: 8:00 AM to 5:00 PM EST  
Part Numbers Technical Applications Specifications Equipment Recommendations
- D. LITERATURE REQUESTS:  
Telephone: (843) 664-5562 / Fax: (843) 664-5548 Hours: 7:30 AM to 4:00 PM EST
- E. WELDING EQUIPMENT REPAIRS:  
Telephone: (843) 664-4487 / Fax: (843) 664-5557 Hours: 7:30 AM to 3:30 PM EST  
Repair Estimates Repair Status
- F. WELDING EQUIPMENT TRAINING  
Telephone: (843)664-4428 / Fax: (843) 679-5864 Hours: 7:30 AM to 4:00 PM EST  
Training School Information and Registrations
- G. WELDING PROCESS ASSISTANCE:  
Telephone: (800) ESAB-123 Hours: 7:30 AM to 4:00 PM EST
- H. TECHNICAL ASST. CONSUMABLES:  
Telephone : (800) 933-7070 Hours: 7:30 AM to 5:00 PM EST

**IF YOU DO NOT KNOW WHOM TO CALL**

Telephone: (800) ESAB-123  
Fax: (843) 664-4462  
Hours: 7:30 AM to 5:00 PM EST  
or  
visit us on the web at <http://www.esabna.com>  
The ESAB web site offers  
Comprehensive Product Information  
Material Safety Data Sheets  
Warranty Registration  
Instruction Literature Download Library  
Distributor Locator  
Global Company Information  
Press Releases  
Customer Feedback & Support