



A6-DK

The Portal Welding Machine

The standard A6-DK-SAW works with a single wire on each head. The welding heads on the machine are controlled from two PEH control boxes and two power sources.

The A6 DK welding machine has two welding heads. It is built up by components from the well-known A6 system. A6 DK is designed for simultaneously welding horizontal-vertical fillets on both sides of a web or through panels.

A6 DK straddles workpieces up to 800 mm high and with a symmetrical profile width of 400 mm. A6 DK travels directly on the workpiece and is guided along the joint with the aid of a guide unit attached to the contact unit. The travel speed is steplessly adjustable from 0.15 to 2.0 m/min.

Main components

PEH Process Controller

A2-A6 Process Controller PEH is the system adapted for use with ESAB's automatic power sources LAF and TAF. The control system is connected to the power source via a control cable and incorporates a bus system for data transfer. The PEH is micro-processor controlled and programmed via menus. A2-A6 Process Controller can easily be pre-set by the user. There are also control keys for manual control of the wire feed and travel direction. The PEH system has constant current (CA) or constant wire speed (CW). The heat input is visible on the display.

Wire feed motor and gear box A6-VEC

A6-VEC consists of a motor with an integral gear box. A6-VEC in combination with the wire straightening unit gives smooth positive wire feed. Since each wire diameter has its own particular feed roll, the latter, which fits on the drive shaft, has been made easy to change.

Carriage

The carriage, upon which the other components are mounted, is a two-wheel portal type. The carriage is



propelled by an A6-VEC motor. Both wheels are driving. The machine can travel round a slight curve if required.

Flux hopper

The flux hopper is made of silumin and can store up to 10 litre flux. From the hopper the flux is fed through a hose to the flux funnel which is attached to the contact unit and is adjustable in height so that a suitable amount of flux always covers the arc and the weld pool.

Flux recovery unit

Each welding head is equipped with the OPC recovery unit. The OPC works on the ejector principle using compressed air. Surplus flux is recovered into the flux hopper for re-use as welding progresses. A cyclone separator, fitted on top of the flux hopper, efficiently separates the recovered flux from dust. The dust is then collected in a fine filter. Flux recovered in this way is passed through a metal grid to retain eventual slag before being returned to the flux hopper.

Technical data

| | |
|--------------------------------------|----------|
| Permissible load 100%, A | 1500 |
| Travel speed, m/min | 0.15-2.0 |
| Wire feed speed, m/min | 0.2-4.0 |
| Wire reel (optional), kg | 2x30 |
| Wire diameter SAW, mm | 3.0-6.0 |
| Flux capacity (each welding head), l | 10 |
| Weight, excl wire and flux, kg | 150 |

Straddle opening

| | |
|--|-----|
| Vertical space limitation, mm | 800 |
| Longitudinal symmetrical extension, mm | 400 |

Ordering information

A6-DK-SAW single wire
excl wire reel, feed rollers
and contact jaws *) 0454 200 901

*) When contact equipment is excluded feed rollers and contact jaws have to be ordered separately.

Optional equipment

Wire reel, plastic, 30 kg 0153 872 880
Wire reel, steel, 30 kg 0416 492 880

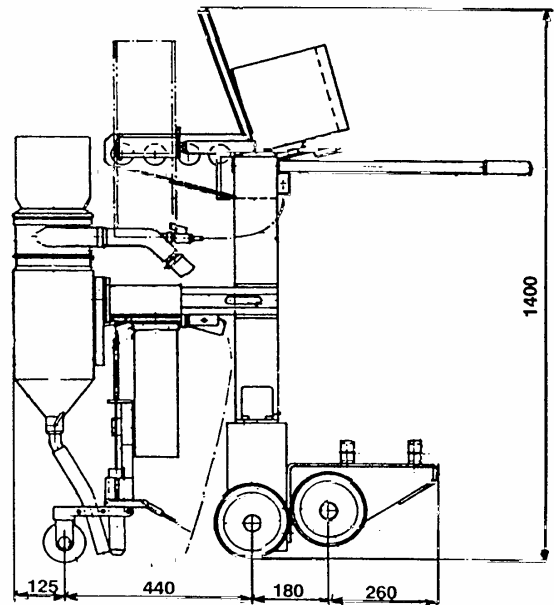
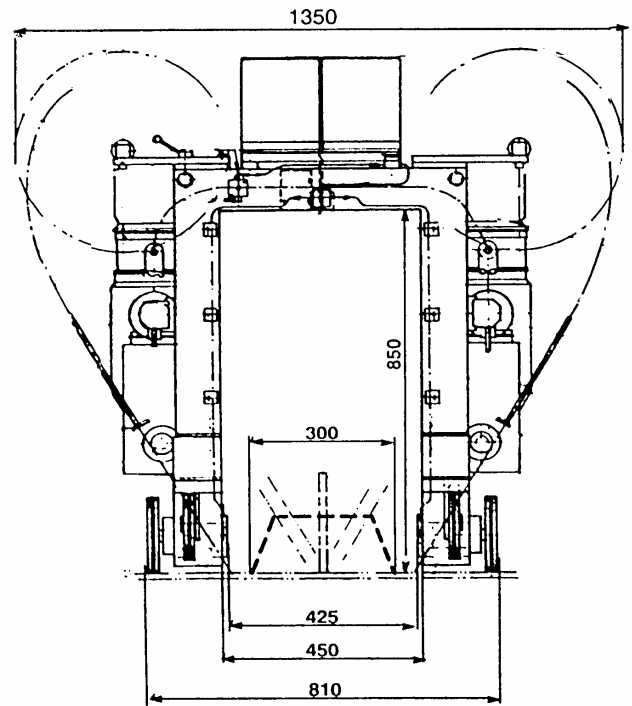

ESAB AB
Welding Equipment
SE-695 81 LAXÅ SWEDEN
Phone: +46 584 81000
Fax +46 584 411721
E-mail: info@esab.se

www.esab.com

