



"MANUFACTURERS OF THE MOST COMPLETE LINE OF FLUX HANDLING EQUIPMENT IN THE WORLD"

34 Fruit St.  
Shrewsbury, MA 01545 (U.S.A.)  
Telephone: (508) 842-2224  
Fax: (508) 842-3893  
Website:  
www.weldengineering.com  
Email:  
Sales@weldengineering.com

**ACCESSORIES FOR THE FOLLOWING FLUX RECOVERY AND FLUX HANDLING SYSTEMS:**

AP-1  
SUPER-AP-1  
AP-1-E/P  
SUPER-AP-1-E/P  
XP-3  
SUPER-FH-100-A/P  
SUPER-HFH-100-A/P  
SUPER-FH-100-A/P-E/P  
SUPER-HFH-100-A/P-E/P

AS-4  
AS-4-E/P  
PS-2  
PS-2-A/P  
SUPER-PS-2-A/P  
APT-2  
APT-2-C  
XP-3TRAC  
XP-3TRAC-C

ALT-2  
ALT-2-C  
PFR-3  
PFR-3-A/P  
SUPER-PFR-3-A/P  
LPFR-3  
LPFR-3-A/P  
SUPER-LPFR-3-A/P  
PT & HPT-"x"00

**1. AV-4 ELECTRIC AIR VALVE.** (For all air powered Flux Vacs.)

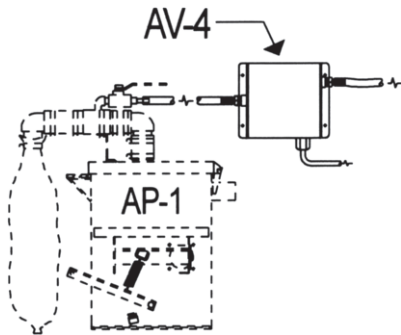

The AV-4 electric air valve is for remotely turning **air powered** flux recovery vacuums on and off (AP-1, SUPER-AP-1, AP-1-E/P, SUPER-AP-1-E/P, XP-3, XP-3TRAC, APT-2, PS-2-A/P, SUPER-PS-2-A/P, and FH-100-AP etc.). The AV-4 is installed between the on/off ball valve of the flux vac, and the air supply. When 115V signal is provided to the AV-4, the valve opens, allowing the flux vac to operate. Standard input voltage is 115V. (Also available in other voltages.)

**See pages 2, 3, 5, 6, 8 and 11 for typical installations.**

**2. FLUX HOSE MOUNTING BRACKETS.**

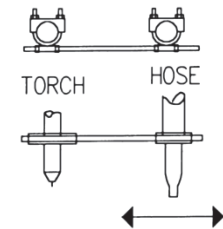

A. The **FHM-1** provides easy positioning of hose over flux. (Linear adjustment only.) For use with all Mighty-Might and Mighty-Mac Recovery Systems.

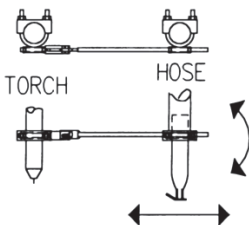

B. The **FHM-1ADJ** provides easy positioning of hose over flux. (Linear and angular adjustment.) For use with all Mighty-Might and Mighty-Mac Recovery Systems.



"MANUFACTURERS OF THE MOST COMPLETE LINE OF FLUX HANDLING EQUIPMENT IN THE WORLD"

34 Fruit St.  
 Shrewsbury, MA 01545 (U.S.A.)  
 Telephone: (508) 842-2224  
 Fax: (508) 842-3893  
 Website:  
 www.weldengineering.com  
 Email:  
 Sales@weldengineering.com

**C. RFHM-7 REAR HOSE MOUNTING BRACKET. (For all tractor flux recovery units.)**

The RFHM-7 rear hose mounting bracket is for use with the Lincoln LT-7 tractor and when welding is done between tractor wheels, or when tractor is riding in 45 degree trough (i.e., Web to flange welds). RFHM-7 enables universal positioning of flux pick-up hose at rear of tractor. (For use with the ALT-2, APT-2, and XP-3TRAC-OTC.)

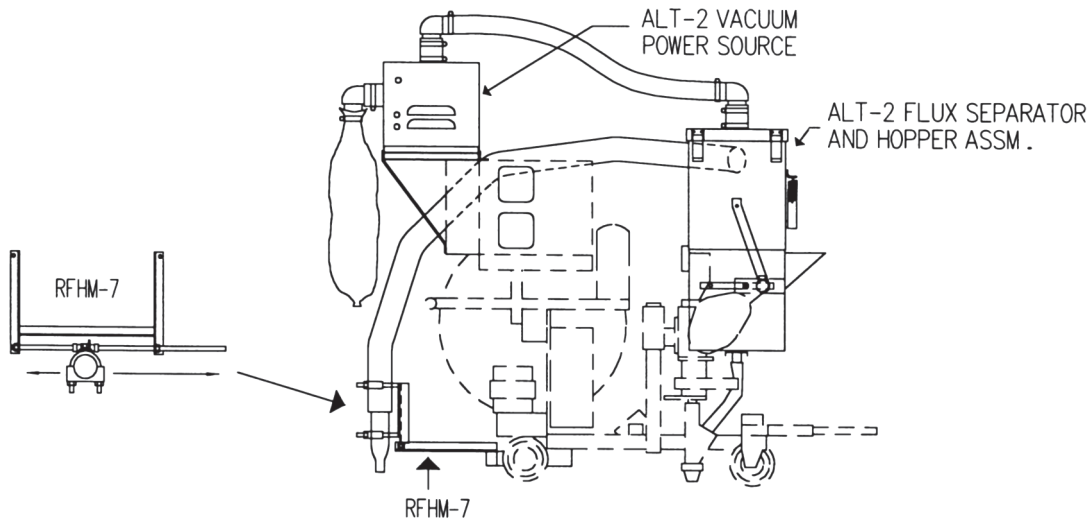

**3. FLUX PICK-UP NOZZLES. (For all flux recovery equipment.)**



A. **NZ-1**; Standard Flux Pick-up Nozzle.



B. **NZ-1-4**; 4" Wide Flux Pick-up Nozzle.  
**(NEW PRODUCT!)**



C. **NZ-1CRN**; Corner Weld Flux Pick-up Nozzle  
 (sold as a pair, one right nozzle, one left nozzle).



D. **NZ-1BUTT**; Butt Weld Flux Pick-up Nozzle.



"MANUFACTURERS OF THE MOST COMPLETE LINE OF FLUX HANDLING EQUIPMENT IN THE WORLD"

34 Fruit St.  
 Shrewsbury, MA 01545 (U.S.A.)  
 Telephone: (508) 842-2224  
 Fax: (508) 842-3893  
 Website:  
 www.weldengineering.com  
 Email:  
 Sales@weldengineering.com

4. DC-30 DUST COLLECTOR.

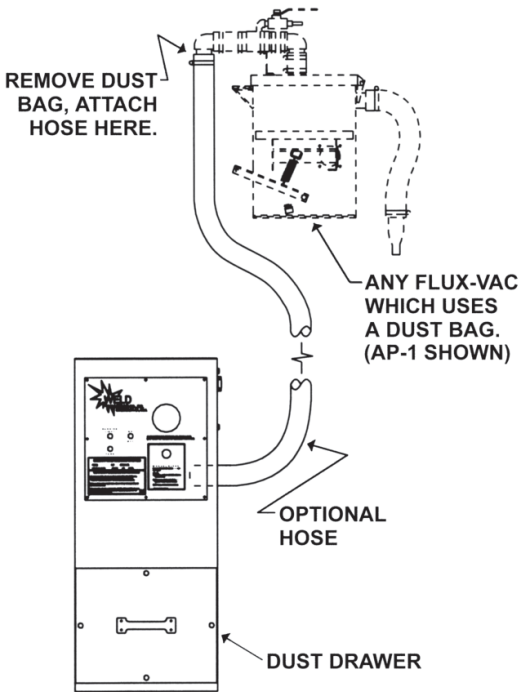

The **DC-30 dust collector** is for use with all stationary flux vacs, which use a dust bag as the standard dust collection method (i.e. AS-4, AP-1, SUPER-AP-1, SUPER-FH-100-A/P, XP-3, etc.). The advantages of the **DC-30** relative to the dust bag are **larger dust holding capacity** (approximately 30 pounds), **elimination of dust bag from welding area**, **easy filter cleaning** (the filter is cleaned by pressing a button which will back pulse the filter with compressed air), **larger more efficient filter area**, **dust drawer for easy removal and dumping of dust** and **greater filter life with less maintenance**. (Does not come with dust hose. Please select length from 2" dust collector hose below.)

5. DUST COLLECTOR HOSE (1 1/2") FOR USE WITH AIR-POWERED UNITS.

- 5 Feet
- 10 Feet
- 15 Feet

DUST COLLECTOR HOSE (2") FOR USE WITH ELECTRIC UNITS.

- 5 Feet
- 10 Feet
- 15 Feet



*"MANUFACTURERS OF THE MOST COMPLETE LINE OF FLUX HANDLING EQUIPMENT IN THE WORLD"*

34 Fruit St.  
 Shrewsbury, MA 01545 (U.S.A.)  
 Telephone: (508) 842-2224  
 Fax: (508) 842-3893  
 Website:  
 www.weldengineering.com  
 Email:  
 Sales@weldengineering.com

**6. MAGNETIC SEPARATORS.**

MAGSEP-1, MAGSEP-2, MAGSEP-100 and MAGSEP-100-E/P Magnetic Separators install in place of the standard slag tray. Its advanced design provides a slag separation tray and powerful magnets to remove magnetic particles from recovered flux. Magnetic particles are easily disposed of by removing the magnetic separator from the flux recovery vacuum, operator then slides magnet assembly out of magnetic collection tubes and magnetic particles fall away to be discarded. (Not available for XP-3, XP-3TRAC and ALT-2.)

**MAGSEP-1 (For AP-1, SUPER-AP-1, SUPER-AP-1-E/P, AP-1-E/P, AS-4, AS-4-E/P, PS-2, PS-2-A/P, SUPER-PS-2-A/P, APT-2, MS-1, AND MS-1-E/P)**



**MAGSEP-2 (For PFR-3, LPFR-3, AND HAMX-50)**



**MAGSEP-100 (For SUPER-FH-100-A/P and SUPER-HFH-100-A/P)**

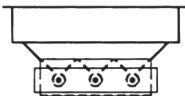

**MAGSEP-100-E/P (For SUPER-FH-100-A/P-E/P, SUPER-HFH-100-A/P-E/P, FH-100-E/P and HFH-100-E/P)**

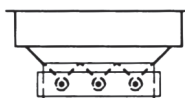



"MANUFACTURERS OF THE MOST COMPLETE LINE OF FLUX HANDLING EQUIPMENT IN THE WORLD"

34 Fruit St.  
 Shrewsbury, MA 01545 (U.S.A.)  
 Telephone: (508) 842-2224  
 Fax: (508) 842-3893  
 Website:  
 www.weldengineering.com  
 Email:  
 Sales@weldengineering.com

**7. PAS-1 PORTABLE FLUX HOPPER.**

The PAS-1 easily converts the AP-1, SUPER-AP-1 and AS-4 into a portable flux recovery system.

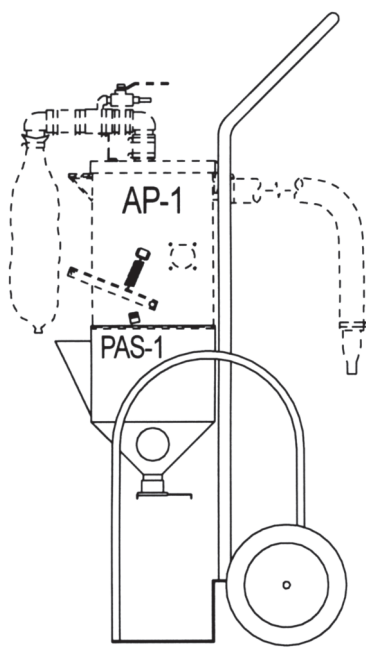

PAS-1/AP-1 comes complete with 10 feet of 1-1/2" hose and flux pick-up nozzle.

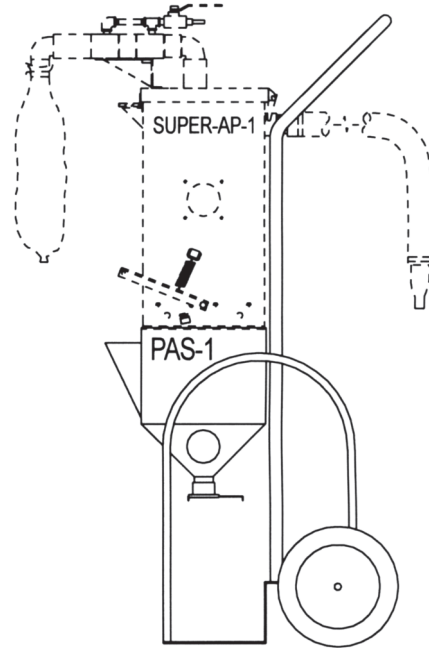

PAS-1/SUPER-AP-1 comes complete with 15 feet of 1-1/2" hose and flux pick-up nozzle.

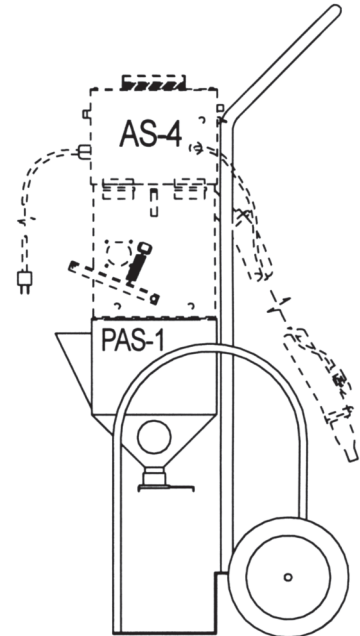

PAS-1/AS-4 comes complete with 15 feet of 1-1/2" hose and flux pick-up nozzle.

**8. FH-1 FLUX HOPPER.**

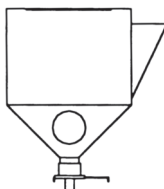

The FH-1 flux hopper is for use with the AS-4, AS-4-E/P, AP-1, SUPER-AP-1, AP-1-E/P, SUPER-AP-1-E/P, MS-1, and MS-1-E/P where greater flux capacity is required. Side loading port of hopper enables operator to add flux to hopper during welding without interrupting the weld, thus providing an unlimited supply of flux. Hopper holds approximately 35 to 40 pounds of flux.

**Note: Customer must provide own mounting bracket. Does not mount directly to welding head because of increased size and flux weight capacity.**

**FH-1-60** flux hopper is the same as above except it holds 60 lbs of flux.



*"MANUFACTURERS OF THE MOST COMPLETE LINE OF FLUX HANDLING EQUIPMENT IN THE WORLD"*

34 Fruit St.  
Shrewsbury, MA 01545 (U.S.A.)  
Telephone: (508) 842-2224  
Fax: (508) 842-3893  
Website:  
www.weldengineering.com  
Email:  
Sales@weldengineering.com

**9. HFH-1 HEATED FLUX HOPPER.**

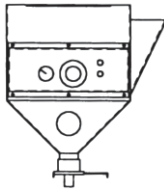

The HFH-1 heated flux hopper is the same as the FH-1 Hopper except it is heated. It has a continuous thermostat control (ambient to 250°F {121°C}) and temperature gauge for those applications where flux must be heated. (Interfaces with same recovery equipment as FH-1 Hopper.) Please specify voltage, 115v/1ph/50-60hz or 220v/1ph/50-60hz.

**HFH-1-60** flux hopper is the same as above except it holds 60 lbs of flux.

**10. FP-1 FLUX PORT.**

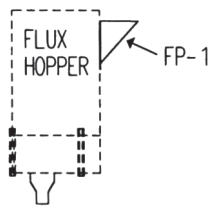

The FP-1 flux port is for the Lincoln hopper or any flat walled hopper. Allows additional flux to be added to hopper without interrupting the weld. Includes aluminum port and pop-rivets. (Not for use with the XP-3 or XP-3TRAC.)

**11. AFV-2 AUTOMATIC FLUX VALVE.**

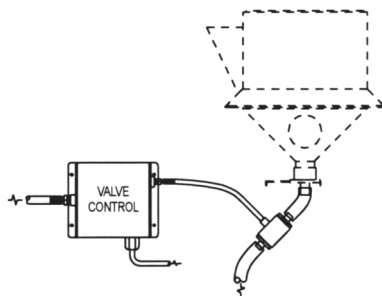

The AFV-2 is an in-line flux pinch valve for 3/4" I.D. flux feed hose. Automatically opens or closes flux flow in 3/4" I.D. hose, when 115v electrical signal is supplied. Use with FH-1, HFH-1, FH-100-E/P, HFH-100-E/P, SUPER-FH-100-A/P-E/P and SUPER-HFH-100-A/P-E/P, or any gravity feed hopper. (Typical use would be to automatically start flux flow when arc-start button is pushed and to stop flow when weld is finished.) System includes flux pinch valve, air on/off solenoid, pressure regulator and five (5) feet of 1/4" I.D. air hose.

Input power: 115v/1ph/50-60hz and standard shop air (other voltages available).

**AFV-2-1 1/2** is the same as above except it is for 1 1/2" I.D. flux feed hose.



"MANUFACTURERS OF THE MOST COMPLETE LINE OF FLUX HANDLING EQUIPMENT IN THE WORLD"

34 Fruit St.  
Shrewsbury, MA 01545 (U.S.A.)  
Telephone: (508) 842-2224  
Fax: (508) 842-3893  
Website:  
www.weldengineering.com  
Email:  
Sales@weldengineering.com

**12. FF-3 FLUX FEED PIPE.**

The FF-3 flux feed pipe enables flux to be fed from a pressure feed tank (PT-"x"00 or other pressure tank is required) to the flux hopper. Flux flow to hopper will automatically stop when flux level inside hopper is higher than inlet pipe. Specify flux feed hose size (1/2", 3/4" or 1" I.D. size available.)

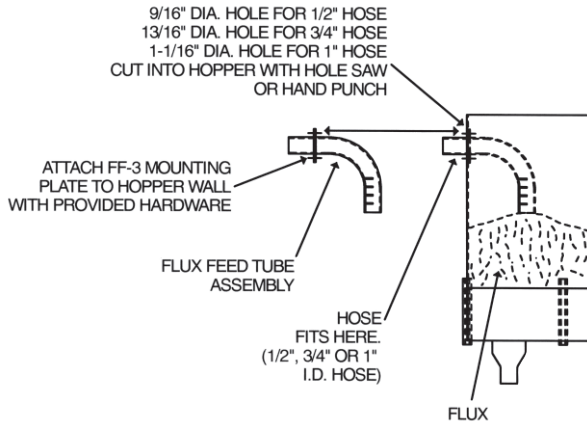

**FF-3-1/2" for 1/2" I.D. hose**  
**FF-3-3/4" for 3/4" I.D. hose**  
**FF-3-1" for 1" I.D. hose**

**13. PFR-LD3 LID.**

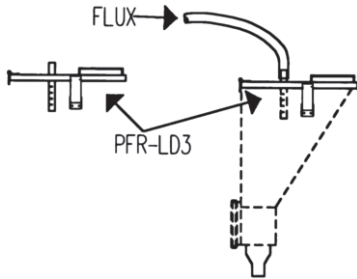

The PFR-LD3 Lid is for attachment to most manufacturer's standard flux hoppers (please specify model of hopper used when ordering), to pressure feed flux to the hopper from a flux feed pressure tank (PT-"x"00, HPT-"x"00, PFR-3 and LPFR-3 systems). Customer has choice of 1/2", 3/4" or 1" I.D. hose fitting.

**14. TNOZ-XX" PRESSURE TANK FLUX FEED NOZZLES.**

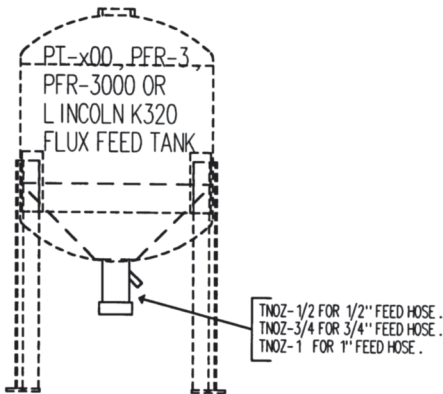

1. **TNOZ-1/2"** - Pressure tank flux feed nozzle for 1/2" I.D. hose. Nozzle fits 2" NPT female pipe fitting which is standard on PFR-3, PT-"x"00, HPT-"x"00, PFR-3000, and Lincoln K320 tanks.  
(Please consult factory for non-standard sizes.)

2. **TNOZ-3/4"** - Same as above, except for 3/4" I.D. flux feed hose.

3. **TNOZ-1"** - Same as above, except for 1" I.D. flux feed hose.



*"MANUFACTURERS OF THE MOST COMPLETE LINE OF FLUX HANDLING EQUIPMENT IN THE WORLD"*

34 Fruit St.  
 Shrewsbury, MA 01545 (U.S.A.)  
 Telephone: (508) 842-2224  
 Fax: (508) 842-3893  
 Website:  
 www.weldengineering.com  
 Email:  
 Sales@weldengineering.com

**15. TANK HIGH/LOW SENSOR.**

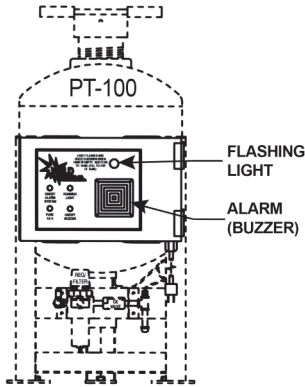

High or low flux level warning lights or audible alarm for flux level. (Consult factory if high and low flux level sensing is required.)

- A. PT-100, PT-300, PT-600, PT-1200, PT-2000, etc.  
 (115V)  
 (220V)
- B. HPT-100, HPT-300, HPT-600, HPT-1200, HPT-2000, etc.  
 (115V)  
 (220V)

**16. FFC-1 FLUX FILLING CONE.**

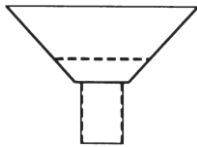

The flux filling cone is for easily adding flux to the PT-"x"00 and HPT-"x"00 flux pressure feed tank systems.

**17. FV-1 IN-LINE FLUX VALVE.**



The FV-1 in-line flux valve, is for hand held sub-arc guns, and PFR-LD3 lid. Trouble free valve fits inside diameter (1/2", 3/4" and 1") flux hose. Installs in minutes and is ready to use.

**FV-1-1/2"** (For 1/2" I.D. Hose)

**FV-1-3/4"** (For 3/4" I.D. Hose)

**FV-1-1"** (For 1" I.D. Hose)

**18. PRESSURE FEED HOSE.**

- 1/2" .....
- 3/4" .....
- 1" .....





"MANUFACTURERS OF THE MOST COMPLETE LINE OF FLUX HANDLING EQUIPMENT IN THE WORLD"

34 Fruit St.  
 Shrewsbury, MA 01545 (U.S.A.)  
 Telephone: (508) 842-2224  
 Fax: (508) 842-3893  
 Website:  
 www.weldengineering.com  
 Email:  
 Sales@weldengineering.com

19. **EXTRA HOSE** (For AP-1, SUPER-AP-1, AP-1-E/P, SUPER-AP-1-E/P, SUPER-FH-100-A/P, SUPER-HFH-100-A/P, SUPER-FH-100-A/P-E/P, SUPER-HFH-100-A/P-E/P, AS-4, AS-4-E/P, PS-2-A/P, SUPER-PS-2-A/P, APT-2, XP-3TRAC, ALT-2, PFR-3-A/P, SUPER-PFR-3-A/P, LPFR-3-A/P, SUPER-LPFR-3-A/P).

- 5 feet .....
- 10 feet .....
- 15 feet .....
- 20 feet .....
- 25 feet .....

20. **EXTRA HOSE** (For PS-2, LPFR-3, PFR-3)

- 5 feet .....
- 10 feet .....
- 15 feet .....
- 20 feet .....
- 25 feet .....

21. **MADP-1 ADAPTER PLATE.**

The MADP-1 is for mounting the AS-4, AS-4-E/P, AP-1, SUPER-AP-1, AP-1-E/P, SUPER-AP-1-E/P, MS-1, and MS-1-E/P to Miller FH308B Hopper.

22. **FD-1 FLUX DAM FOR BUILDING UP SMALL DIAMETER ROLLS.**

The FD-1 Flux Dam "dams" flux on cylindrical welding applications, to enable proper flux coverage and keeps flux from cascading off the cylinder.

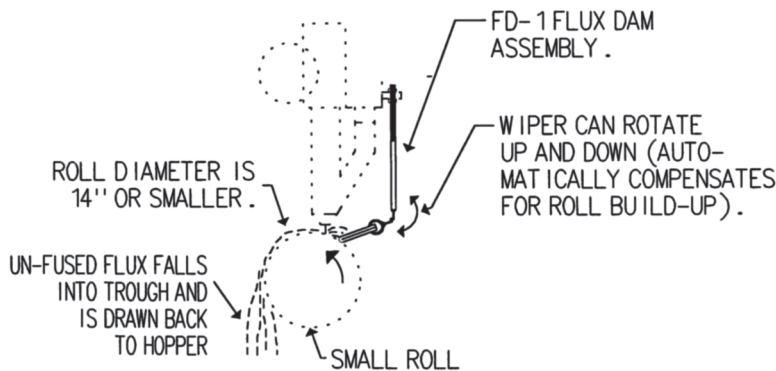



*"MANUFACTURERS OF THE MOST COMPLETE LINE  
OF FLUX HANDLING EQUIPMENT IN THE WORLD"*

34 Fruit St.  
Shrewsbury, MA 01545 (U.S.A.)  
Telephone: (508) 842-2224  
Fax: (508) 842-3893  
Website:  
[www.weldengineering.com](http://www.weldengineering.com)  
Email:  
[Sales@weldengineering.com](mailto:Sales@weldengineering.com)

**23. HEAVY DUTY KIT FOR AIR POWERED FLUX VACS.**

- A. **AP-1-HD** is for single air pump flux vacs. Includes stainless steel air jet, heavy duty elbows and a special dust bag air diffuser.
  
- B. **AP-2-HD** is for super flux vacs with dual air pumps. Same as above except it includes two (2) stainless steel air jets.



*"MANUFACTURERS OF THE MOST COMPLETE LINE OF FLUX HANDLING EQUIPMENT IN THE WORLD"*

34 Fruit St.  
 Shrewsbury, MA 01545 (U.S.A.)  
 Telephone: (508) 842-2224  
 Fax: (508) 842-3893  
 Website:  
 www.weldengineering.com  
 Email:  
 Sales@weldengineering.com

**RECOMMENDED CONSUMABLE PARTS FOR  
 "MIGHTY-MIGHT" FLUX RECOVERY SYSTEMS**

\*\*\*\*\*

- |  |  |
|--|--|
| <p>1. AP-1<br/>         SUPER-AP-1<br/>         AP-1-E/P<br/>         SUPER-AP-1-E/P<br/>         APT-2<br/>         APT-2-C<br/>         PS-2-A/P<br/>         SUPER-PS-2-A/P<br/>         PFR-3-A/P<br/>         SUPER-PFR-3-A/P<br/>         LPFR-3-A/P<br/>         SUPER-LPFR-3-A/P</p> | <p>A. 1 each Rubber Impingement Plates</p> <p>B. 1 each Dust Bag Assembly</p> <p>C. 1 each Exhaust Elbows<br/>         (1 pair)</p> <p>D. AP-1, AP-1-E/P, APT-2, APT-2-C, PS-2-A/P, PFR-3-A/P, LPFR-3-A/P Air Pump</p> <p>E. SUPER-AP-1, SUPER-AP-1-E/P<br/>         SUPER-PS-2-A/P, SUPER-PFR-3-A/P<br/>         SUPER-LPFR-3-A/P Air Pump</p> <p>F. Air Jet (two required for SUPER's)</p> |
|--|--|

\*\*\*\*\*

- |  |  |
|--|--|
| <p>2. SUPER-FH-100-A/P<br/>         SUPER-HFH-100-A/P<br/>         SUPER FH-100-A/P-E/P<br/>         SUPER-HFH-100-E/P</p> | <p>A. 1 each Rubber Impingement Plates</p> <p>B. 1 each Dust Bag Assembly</p> <p>C. 1 each Exhaust Elbows (1 pair)</p> <p>D. Air Pumps</p> <p>E. Air Jets (two required)</p> |
|--|--|

\*\*\*\*\*

- |   |  |
|---|--|
| <p>3. AS-4<br/>         PS-2<br/>         ALT-2<br/>         ALT-2-C<br/>         PFR-3<br/>         LPFR-3</p> | <p>A. 1 each Fine Flux Filter</p> <p>B. 1 each Dust Bag Assembly</p> <p>C. 1 each Motor Filter</p> <p>D. Vacuum Motor 115V</p> <p>E. Vacuum Motor 220V</p> |
|---|--|

\*\*\*\*\*

- |  |  |
|--|--|
| <p>4. XP-3<br/>         XP-3TRAC<br/>         XP-3TRAC-C</p> | <p>A. 1 each XP-3 Flux Filter</p> <p>B. 1 each Dust Bag Assembly</p> <p>C. Air Pump</p> <p>D. Air Jets</p> |
|--|--|

\*\*\*\*\*

**ALL EQUIPMENT - F.O.B. - OUR FACTORY  
 Prices subject to change without notice,  
 and are those in effect at time of order.**