

**PFB-R  
BENCH SEAM WELDERS**

Rugged steel frame;  
Water-cooled welding transformer;  
Water-cooled welding wheels  $\varnothing$  85mm;  
PX1700PRO AC welding control;  
Safety thermostats.

Optional

TECHNICAL DATA		PFB-R 116	PFB-R 126	PFB-R 136
NOMINAL POWER 50% DUTY CYCLE	kVA	15	25	35
SHORT CIRCUIT SEC. CURRENT	kA	9	12.6	15
MAX SEC. WELDING CURRENT	kA	7.2	10	12
ELECTRODE FORCE ADJUSTMENT	daN	80-150	80-150	80-150
PERMANENT SECONDARY CURRENT	kA	3.5	4.2	4.9
SECONDARY VOLTAGE	V	3	4.2	5
NOMINAL POWER SUPPLY SINGLE PHASE	V	400	400	400
NOMINAL SUPPLY FREQUENCY	Hz	50/60	50/60	50/60
DELAYED FUSES	A	25	45	63
AIR CONSUMPTION	l/weld	2.65	2.65	2.65
WATER CONSUMPTION	l/min	3	3.0	3
MINIMUM COMPRESSED AIR LINE PRESSURE	bar	6.5	6.5	6.5
DRIVEN WHEEL SPEED	rpm	2÷8.5	2÷8.5	2÷8.5
ELECTRODES STROKE	mm	60	60	60
DIMENSIONS	LxWxH	mm	See attached dwg	See attached dwg
WEIGHT		Kg	150	160

Westermans International Ltd  
Unit 4 Midland Distribution Centre  
Markfield Road, Groby  
Leicestershire, LE6 0FS

www.westermans.com    Welding@westermans.com    Tel:+44(0) 116 2696941

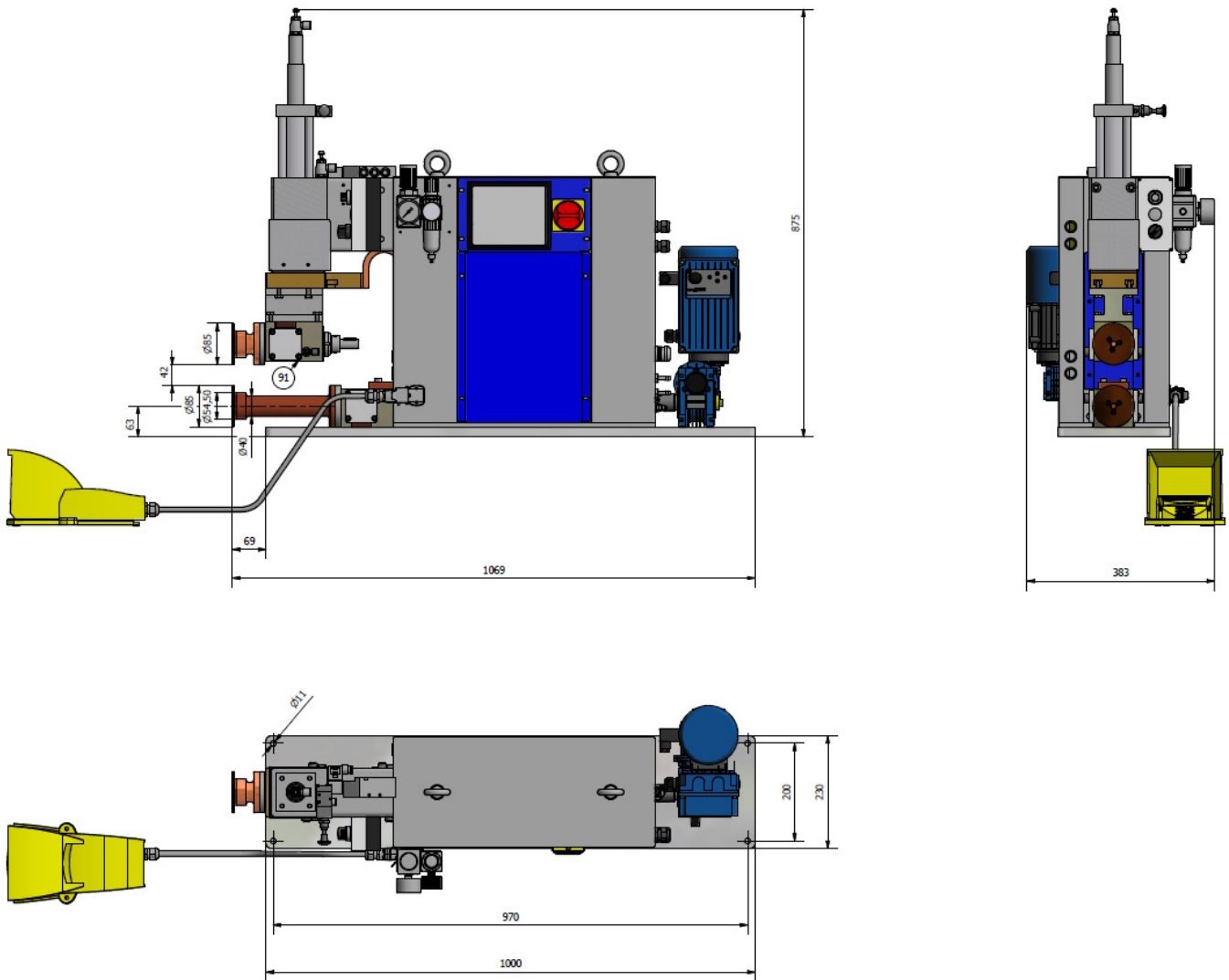

Westermans International Ltd  
 Unit 4 Midland Distribution Centre  
 Markfield Road, Groby  
 Leicestershire, LE6 0FS

www.westermans.com welding@westermans.com Tel:+44(0) 116 2696941