

**VR 7000**

**VR 7000 - 11**

**VR 7000 - 30**

**VR 7000 CMT**

 Operating Instructions  
Spare Parts List

Wirefeeder

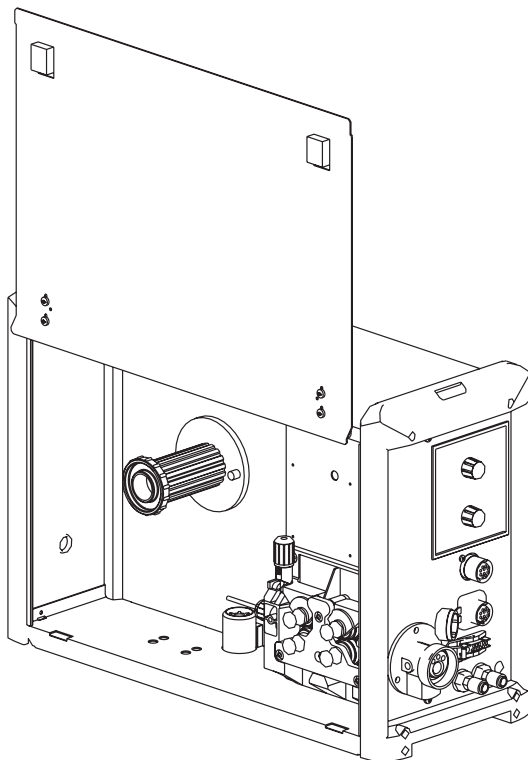



# Dear Reader

## Introduction

Thank you for choosing Fronius - and congratulations on your new, technically high-grade Fronius product! This instruction manual will help you get to know your new machine. Read the manual carefully and you will soon be familiar with all the many great features of your new Fronius product. This really is the best way to get the most out of all the advantages that your machine has to offer.

Please also take special note of the safety rules - and observe them! In this way, you will help to ensure more safety at your product location. And of course, if you treat your product carefully, this definitely helps to prolong its enduring quality and reliability - things which are both essential prerequisites for getting outstanding results.





# Safety rules

## DANGER!



“**DANGER!**” indicates an imminently hazardous situation which, if not avoided, will result in death or serious injury. This signal word is to be limited to the most extreme situations. This signal word is not used for property damage hazards unless personal injury risk appropriate to this level is also involved.



## WARNING!



“**WARNING!**” indicates a potentially hazardous situation which, if not avoided, could result in death or serious injury. This signal word is not used for property damage hazards unless personal injury risk appropriate to this level is also involved.

## CAUTION!



“**CAUTION!**” indicates a potentially hazardous situation which, if not avoided, may result in minor or moderate injury. It may also be used to alert alert against unsafe practices that may cause property damage.

## NOTE!



“**NOTE!**” indicates a situation which implies a risk of impaired welding result and damage to the equipment.

## Important!

“**Important!**” indicates practical hints and other useful special-information. It is no signal word for a harmful or dangerous situation.

Whenever you see any of the symbols shown above, you must pay even closer attention to the contents of the manual!

## General remarks



This equipment has been made in accordance with the state of the art and all recognised safety rules. Nevertheless, incorrect operation or misuse may still lead to danger for

- the life and well-being of the operator or of third parties,
- the equipment and other tangible assets belonging to the owner/operator,
- efficient working with the equipment.

All persons involved in any way with starting up, operating, servicing and maintaining the equipment must

- be suitably qualified
- know about welding and
- read and follow exactly the instructions given in this manual.

The instruction manual must be kept at the machine location at all times. In addition to the instruction manual, copies of both the generally applicable and the local accident prevention and environmental protection rules must be kept on hand, and of course observed in practice.

All the safety instructions and danger warnings on the machine itself:

- must be kept in a legible condition
- must not be damaged

## General remarks

(continued)

- must not be removed
- must not be covered, pasted or painted over

For information about where the safety instructions and danger warnings are located on the machine, please see the section of your machine's instruction manual headed "General remarks".

Any malfunctions which might impair machine safety must be eliminated immediately - meaning before the equipment is next switched on.

### It's your safety that's at stake!

## Utilisation for intended purpose only



The machine may only be used for jobs as defined by the "Intended purpose".

The machine may ONLY be used for the welding processes stated on the rating plate.

Utilisation for any other purpose, or in any other manner, shall be deemed to be "not in accordance with the intended purpose". The manufacturer shall not be liable for any damage resulting from such improper use.

Utilisation in accordance with the "intended purpose" also comprises

- complete reading and following of all the instructions given in this manual
- complete reading and following of all the safety instructions and danger warnings
- performing all stipulated inspection and servicing work.

The appliance must never be used for the following:

- Thawing pipes
- Charging batteries/accumulators
- Starting engines

The machine is designed to be used in industrial and workshop environments. The manufacturer shall not be liable for any damage resulting from use of the machine in residential premises.

Likewise the manufacturer will accept no liability for defective or faulty work results.

## Ambient conditions



Operation or storage of the power source outside the stipulated range is deemed to be "not in accordance with the intended use". The manufacturer shall not be liable for any damage resulting herefrom.

Temperature range of ambient air:

- when operating: - 10 °C to + 40 °C (14 °F to 104 °F)
- when being transported or stored: - 25 °C to + 55 °C (-13 °F to 131 °F)

Relative atmospheric humidity:

- up to 50 % at 40 °C (104 °F)
- up to 90 % at 20 °C (68 °F)

Ambient air: Free of dust, acids, corrosive gases or substances etc.

Elevation above sea level: Up to 2000 m (6500 ft)

## Obligations of owner/operator



- The owner/operator undertakes to ensure that the only persons allowed to work with the machine are persons who
- are familiar with the basic regulations on workplace safety and accident prevention and who have been instructed in how to operate the machine
  - have read and understood the sections on “safety rules” and the “warnings” contained in this manual, and have confirmed as much with their signatures
  - be trained in such a way that meets with the requirements of the work results

Regular checks must be performed to ensure that personnel are still working in a safety-conscious manner.

## Obligations of personnel



- Before starting work, all persons to be entrusted with carrying out work with (or on) the machine shall undertake
- to observe the basic regulations on workplace safety and accident prevention
  - to read the sections on “safety rules” and the “warnings” contained in this manual, and to sign to confirm that they have understood these and will comply with them.

Before leaving the workplace, personnel must ensure that there is no risk of injury or damage being caused during their absence.

## Protection for yourself and other persons



- When welding, you are exposed to many different hazards such as:
- flying sparks and hot metal particles
  - arc radiation which could damage your eyes and skin



- harmful electromagnetic fields which may put the lives of cardiac pace-maker users at risk



- electrical hazards from mains and welding current



- increased exposure to noise



- noxious welding fumes and gases.

Anybody working on the workpiece during welding must wear suitable protective clothing with the following characteristics:

- flame-retardant
- isolating and dry
- must cover whole body, be undamaged and in good condition
- protective helmet
- trousers with no turn-ups



## Protection for yourself and other persons (continued)



“Protective clothing” also includes:

- protecting your eyes and face from UV rays, heat and flying sparks with an appropriate safety shield containing appropriate regulation filter glass
- wearing a pair of appropriate regulation goggles (with sideguards) behind the safety shield
- wearing stout footwear that will also insulate even in wet conditions
- protecting your hands by wearing appropriate gloves (electrically insulating, heat-proof)



To lessen your exposure to noise and to protect your hearing against injury, wear ear-protectors!



Keep other people - especially children - well away from the equipment and the welding operation while this is in progress. If there are still any other persons nearby during welding, you must

- draw their attention to all the dangers (risk of being dazzled by the arc or injured by flying sparks, harmful welding fumes, high noise immission levels, possible hazards from mains or welding current ...)
- provide them with suitable protective equipment and/or
- erect suitable protective partitions or curtains.

## Hazards from noxious gases and vapours



The fumes given off during welding contain gases and vapors that are harmful to health.

Welding fumes contain substances which may cause birth defects and cancers.

Keep your head away from discharges of welding fumes and gases.

Do not inhale any fumes or noxious gases that are given off.

Extract all fumes and gases away from the workplace, using suitable means.

Ensure a sufficient supply of fresh air.

Where insufficient ventilation is available, use a respirator mask with an independent air supply.

If you are not sure whether your fume-extraction system is sufficiently powerful, compare the measured pollutant emission values with the permitted threshold limit values.

The harmfulness of the welding fumes will depend on e.g. the following components:

- the metals used in and for the workpiece
- the electrodes
- coatings
- cleaning and degreasing agents and the like

For this reason, pay attention to the relevant Materials Safety Data Sheets and the information given by the manufacturer regarding the components listed above.

Keep all flammable vapors (e.g. from solvents) well away from the arc radiation.



## Hazards from flying sparks



Flying sparks can cause fires and explosions!

Never perform welding anywhere near combustible materials.

Combustible materials must be at least 11 meters (35 feet) away from the arc, or else must be covered over with approved coverings.

Have a suitable, approved fire extinguisher at the ready.

Sparks and hot metal particles may also get into surrounding areas through small cracks and openings. Take suitable measures here to ensure that there is no risk of injury or fire.

Do not perform welding in locations that are at risk from fire and/or explosion, or in enclosed tanks, barrels or pipes, unless these latter have been prepared for welding in accordance with the relevant national and international standards.

Welding must NEVER be performed on containers that have had gases, fuels, mineral oils etc. stored in them. Even small traces of these substances left in the containers are a major explosion hazard.

## Hazards from mains and welding current



An electric shock can be fatal. Every electric shock is hazardous to life.

Do not touch any live parts, either inside or outside the machine.



In MIG/MAG and TIG welding, the welding wire, the wire spool, the drive rollers and all metal parts having contact with the welding wire are also live.

Always place the wirefeeder on an adequately insulated floor or base, or else use a suitable insulating wirefeeder holder.

Ensure sufficient protection for yourself and for other people by means of a dry base or cover that provides adequate insulation against the ground/frame potential. The base or cover must completely cover the entire area between your body and the ground/frame potential.

All cables and other leads must be firmly attached, undamaged, properly insulated and adequately dimensioned. Immediately replace any loose connections, scorched, damaged or underdimensioned cables or other leads.

Do not loop any cables or other leads around your body or any part of your body.

Never immerse the welding electrode (rod electrode, tungsten electrode, welding wire, ...) in liquid in order to cool it, and never touch it when the power source is ON.

Twice the open-circuit voltage of one single welding machine may occur between the welding electrodes of two welding machines. Touching the potentials of both electrodes simultaneously may be fatal.

Have the mains and the machine supply leads checked regularly by a qualified electrician to ensure that the PE (protective earth) conductor is functioning correctly.

Only run the machine on a mains network with a PE conductor, and plugged into a power outlet socket with a protective-conductor contact.



## Hazards from mains and welding current

(continued)

If the machine is run on a mains network without a PE conductor and plugged into a power outlet socket without a protective-conductor contact, this counts as gross negligence and the manufacturer shall not be liable for any resulting damage.

Wherever necessary, use suitable measures to ensure that the workpiece is sufficiently grounded (earthed).

Switch off any appliances that are not in use.

When working at great heights, wear a safety harness.

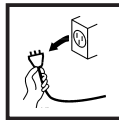

Before doing any work on the machine, switch it off and unplug it from the mains.

Put up a clearly legible and easy-to-understand warning sign to stop anybody inadvertently plugging the machine back into the mains and switching it back on again.

After opening up the machine:

- discharge any components that may be storing an electrical charge
- ensure that all machine components are electrically dead.

If work needs to be performed on any live parts, there must be a second person on hand to immediately switch off the machine at the main switch in an emergency.

## Stray welding currents



If the following instructions are ignored, stray welding currents may occur. These can cause:

- fires
- overheating of components that are connected to the workpiece
- destruction of PE conductors
- damage to the machine and other electrical equipment

Ensure that the workpiece clamp is tightly connected to the workpiece.

Attach the workpiece clamp as close as possible to the area to be welded.

On electrically conductive floors, the machine must be set up in such a way that it is sufficiently insulated from the floor.

When using current supply distributors, twin head wire feeder fixtures etc., please note the following: The electrode on the unused welding torch/welding tongs is also current carrying. Please ensure that there is sufficient insulating storage for the unused welding torch/tongs.

## EMC and EMI Precautions



It is the responsibility of the owner/operator to ensure that no electromagnetic interference is caused to electrical and electronic equipment.

If electromagnetic interference is found to be occurring, the owner/operator is obliged to take all necessary measures to prevent this interference.

Examine and evaluate any possible electromagnetic problems that may occur on equipment in the vicinity, and the degree of immunity of this equipment, in accordance with national and international regulations:

- safety features
- mains, signal and data-transmission leads
- IT and telecoms equipment
- measurement and calibration devices

Ancillary measures for preventing EMC problems:

a) Mains supply

- If electromagnetic interference still occurs, despite the fact that the mains connection is in accordance with the regulations, take additional measures (e.g. use a suitable mains filter).

b) Welding cables

- Keep these as short as possible
- Arrange them so that they run close together (to prevent EMI problems as well)
- Lay them well away from other leads.

c) Equipotential bonding

d) Workpiece grounding (earthing)

- where necessary, run the connection to ground (earth) via suitable capacitors.

e) Shielding, where necessary

- Shield other equipment in the vicinity
- Shield the entire welding installation.

Electromagnetic fields may cause as yet unknown damage to health.

- Effects on the health of persons in the vicinity, e.g. users of heart pace-makers and hearing aids
- Users of heart pacemakers must take medical advice before going anywhere near welding equipment or welding workplaces
- Keep as much space as possible between welding cables and head/body of welder for safety reasons
- Do not carry welding cables and hose pack over shoulder and do not loop around body or any part of body

## Particular danger spots



Keep your hands, hair, clothing and tools well away from all moving parts, e.g.:

- fans
- toothed wheels, rollers, shafts
- wire-spools and welding wires

Do not put your fingers anywhere near the rotating toothed wheels of the wirefeed drive.0

Covers and sideguards may only be opened or removed for as long as is absolutely necessary to carry out maintenance and repair work.



**Particular danger spots**  
(continued)

While the machine is in use:

- ensure that all the covers are closed and that all the sideguards are properly mounted ...
- ... and that all covers and sideguards are kept closed.



When the welding wire emerges from the torch, there is a high risk of injury (the wire may pierce the welder's hand, injure his face and eyes ...). For this reason, when feeder-inching etc., always hold the torch so that it is pointing away from your body (machines with wirefeeder).



Do not touch the workpiece during and after welding - risk of injury from burning!

Slag may suddenly "jump" off workpieces as they cool. For this reason, continue to wear the regulation protective gear, and to ensure that other persons are suitably protected, when doing post-weld finishing on workpieces.

Allow welding torches - and other items of equipment that are used at high operating temperatures - to cool down before doing any work on them.



Special regulations apply to rooms at risk from fire and/or explosion. Observe all relevant national and international regulations.



Risk of scalding from accidental discharge of hot coolant. Before unplugging the connectors for coolant forward flow and return flow, switch off the cooling unit.



Power sources for use in spaces with increased electrical danger (e.g. boilers) must be identified by the  (for "safety") mark. However, the power source should not be in such rooms.



When hoisting the machines by crane, only use suitable manufacturer-supplied lifting devices.

- Attach the chains and/or ropes to **all** the hoisting points provided on the suitable lifting device.
- The chains and/or ropes must be at an angle which is as close to the vertical as possible.
- Remove the gas cylinder and the wirefeed unit (from MIG/MAG and TIG units).

When hoisting the wirefeed unit by crane during welding, always use a suitable, insulating suspension arrangement (MIG/MAG and TIG units).

If a machine is fitted with a carrying strap or carrying handle, remember that this strap is **ONLY** to be used for lifting and carrying the machine by hand. The carrying strap is **NOT** suitable for transporting the machine by crane, fork-lift truck or by any other mechanical hoisting device.



Danger of colourless and odourless inert gas escaping unnoticed, when using an adapter for the inert gas protection. Seal the adapter thread for the inert gas connection using Teflon tape before assembly.

## Danger from shielding-gas cylinders



Shielding-gas cylinders contain pressurized gas and may explode if they are damaged. As shielding-gas cylinders are an integral part of the overall welding outfit, they also have to be treated with great care.

Protect shielding-gas cylinders containing compressed gas from excessive heat, mechanical impact, slag, naked flames, sparks and arcs.

Mount the shielding-gas cylinders in the vertical and fasten them in such a way that they cannot fall over (i.e. as shown in the instruction manual).

Keep shielding-gas cylinders well away from welding circuits (and, indeed, from any other electrical circuits).

Never hang a welding torch on a shielding-gas cylinder.

Never touch a shielding-gas cylinder with a welding electrode.

Explosion hazard - never perform welding on a pressurized shielding-gas cylinder.

Use only shielding-gas cylinders that are suitable for the application in question, together with matching, suitable accessories (pressure regulators, hoses and fittings, ...). Only use shielding-gas cylinders and accessories that are in good condition.

When opening the valve of a shielding-gas cylinder, always turn your face away from the outlet nozzle.

Close the shielding-gas cylinder valve when no welding is being carried out.

When the shielding-gas cylinder is not connected up, leave the cap in place on the shielding-gas cylinder valve.

Observe the manufacturer's instructions and all relevant national and international rules applying to shielding-gas cylinders and accessories.

## Safety precautions at the installation site and when being transported



A machine that topples over can easily kill someone! For this reason, always place the machine on an even, firm floor in such a way that it stands firmly.  
- An angle of inclination of up to 10° is permissible.



Special regulations apply to rooms at risk from fire and/or explosion. Observe all relevant national and international regulations.

By means of internal instructions and checks, ensure that the workplace and the area around it are always kept clean and tidy.

The appliance must only be installed and operated in accordance with the protection type stated on the specifications plate.

When installing the appliance, please ensure a clearance radius of 0.5 m (1.6ft.) , so that cool air can circulate freely.

When transporting the appliance, please ensure that the valid national and regional guidelines and accident protection regulations are followed. This applies in particular to guidelines in respect of dangers during transportation and carriage.



**Safety precautions at the installation site and when being transported**  
(continued)

Before transportation, completely drain any coolant and dismantle the following components:

- Wire feed
- Wire wound coil
- Gas bottle

Before commissioning and after transportation, a visual check for damage must be carried out. Any damage must be repaired by trained service personnel before commissioning.

**Safety precautions in normal operation**



Only operate the machine if all of its protective features are fully functional. If any of the protective features are not fully functional, this endangers:

- the life and well-being of the operator or other persons
- the equipment and other tangible assets belonging to the owner/operator
- efficient working with the equipment.

Any safety features that are not fully functional must be put right before you switch on the machine.

Never evade safety features and never put safety features out of order.

Before switching on the machine, ensure that nobody can be endangered by your doing so.

- At least once a week, check the machine for any damage that may be visible from the outside, and check that the safety features all function correctly.
- Always fasten the shielding-gas cylinder firmly, and remove it altogether before hoisting the machine by crane.
- Owing to its special properties (in terms of electrical conductivity, frost-proofing, materials-compatibility, combustibility etc.), only original coolant of the manufacturer is suitable for use in our machines.
- Only use suitable original coolant of the manufacturer.
- Do not mix original coolant of the manufacturer with other coolants.
- If any damage occurs in cases where other coolants have been used, the manufacturer shall not be liable for any such damage, and all warranty claims shall be null and void.
- Under certain conditions, the coolant is flammable. Only transport the coolant in closed original containers, and keep it away from sources of ignition.
- Used coolant must be disposed of properly in accordance with the relevant national and international regulations. A safety data sheet is available from your service centre and on the manufacturer's homepage.
- Before starting welding - while the machine is still cool - check the coolant level.

**Preventive and corrective maintenance**



With parts sourced from other suppliers, there is no certainty that these parts will have been designed and manufactured to cope with the stressing and safety requirements that will be made of them. Use only original spares and wearing parts (this also applies to standard parts).

Do not make any alterations, installations or modifications to the machine without getting permission from the manufacturer first.

Replace immediately any components that are not in perfect condition.

## Preventive and corrective maintenance

(continued)

When ordering spare parts, please state the exact designation and the relevant part number, as given in the spare parts list. Please also quote the serial number of your machine.

## Safety inspection



The owner/operator is obliged to have a safety inspection performed on the machine at least once every 12 months.

The manufacturer also recommend the same (12-month) interval for regular calibration of power sources.

A safety inspection, by a trained and certified electrician, is prescribed:

- after any alterations
- after any modifications or installations of additional components
- following repairs, care and maintenance
- at least every twelve months.

Observe the relevant national and international standards and directives in connection with the safety inspection.

More detailed information on safety inspections and calibration is available from your regional or national service centre, who will be pleased to provide you with copies of the necessary documents upon request.

## Disposal



Do not dispose of this device with normal domestic waste!

To comply with the European Directive 2002/96/EC on Waste Electrical and Electronic Equipment and its implementation as national law, electrical equipment that has reached the end of its life must be collected separately and returned to an approved recycling facility. Any device that you no longer require must be returned to our agent, or find out about the approved collection and recycling facilities in your area.

Ignoring this European Directive may have potentially adverse effects on the environment and your health!

## Safety markings



Equipment with CE-markings fulfils the basic requirements of the Low-Voltage and Electromagnetic Compatibility Guideline (e.g. relevant product standards according to EN 60 974).



Equipment marked with the CSA-Test Mark fulfils the requirements made in the relevant standards for Canada and the USA.

## Data security

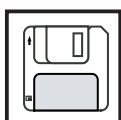

The user is responsible for the data security of changes made to factory settings. The manufacturer is not liable, if personal settings are deleted.



## Copyright



Copyright to this instruction manual remains the property of the manufacturer.

The text and illustrations are all technically correct at the time of going to print. The right to effect modifications is reserved. The contents of the instruction manual shall not provide the basis for any claims whatever on the part of the purchaser. If you have any suggestions for improvement, or can point out to us any mistakes which you may have found in the manual, we should be most grateful for your comments.



# Contents

General remarks .....	3
Machine concept .....	3
Requirements .....	3
Field of application .....	3
Warning notices affixed to the machine .....	4
Options .....	5
„Mode“ switch option .....	5
VR 4000 Ci control panel option and VR 4000 digital display option .....	5
Optional installation and modification sets .....	6
Controls .....	8
General remarks .....	8
Controls .....	8
Connections and mechanical components .....	10
Wirefeeder front .....	10
Wirefeeder rear .....	11
Wirefeeder left side .....	11
Wirefeeder right side .....	13
Wirefeeder underside .....	13
Placing wirefeeder on power source .....	14
General remarks .....	14
Placing wirefeeder on power source .....	14
Connecting wirefeeder to power source .....	15
General remarks .....	15
Connecting wirefeeder to power source .....	15
Connecting the welding torch .....	16
Welding torch connections .....	16
Safety .....	16
Connecting MIG/MAG manual welding torch .....	16
Connecting MIG/MAG robot welding torch, connecting MIG/MAG machine welding torch .....	17
Connecting CMT drive unit .....	17
Inserting/changing feed rollers .....	18
General remarks .....	18
USA wirefeeders .....	18
Inserting/changing feed rollers .....	18
Inserting the wirepool, inserting the basket-type spool .....	19
Safety .....	19
Inserting the wire spool .....	19
Inserting basket-type spool .....	19
Feeding in the welding wire .....	20
Feeding in the welding wire .....	20
Setting the contact pressure .....	21
Adjusting the brake .....	22
General remarks .....	22
Adjusting the brake .....	22
Design of the brake .....	22
Fitting wirefeeding hose for external welding wire .....	23
General remarks .....	23
Fitting wirefeeding hose for external welding wire .....	23



Commissioning .....	24
General remarks .....	24
Requirements .....	24
Care, maintenance and disposal .....	25
General remarks .....	25
Every start-up .....	25
Every 6 months .....	25
Disposal .....	25
Technical data .....	26
VR 7000 .....	26
VR 7000 - 11 .....	26
VR 7000 -30 .....	27
VR 7000 CMT .....	27
Spare parts list	
Fronius Worldwide	

# General remarks

## Machine concept



VR 7000 wirefeeder



VR 7000 CMT wirefeeder

Wirefeeders in the VR 7000 series are designed for wirepools with a maximum diameter of 300 mm (11.81 in.). The wirepool holder can be found inside the wirefeeder housing. The wirepool is thus protected from soiling.

The standard 4-roll drive has good wirefeeding properties. The wirefeeders in the VR 7000 series are also suitable for long hosepacks.

Due to their compact design, the VR 7000 wirefeeders can be used in many different ways.

## Requirements

The VR 7000 wirefeeders can be operated with the following power sources:

- TransSynergic 4000/5000/7200/9000
- TransPuls Synergic 3200/4000/5000/7200/9000
- TransPuls Synergic 2700 Duo
- TransPuls Synergic 2700 Duo TIG

The „CMT (Cold Metal Transfer)“ welding process is only possible with VR 7000 CMT in conjunction with an appropriate CMT power source and drive unit.

## Field of application

- VR 7000: for all types of MIG/MAG welding
- VR 7000 - 11, VR 7000 - 30: primarily used with TS/TPS 7200 and TS/TPS 9000 high-performance power sources
- VR 7000 - 11: also for flux-core wire applications
- VR 7000 CMT: for „CMT“ welding process, for all types of MIG/MAG welding

All variants of the VR 7000 are suitable for all standard shielding gases.



**Note!** The VR 7000 - 11 and VR 7000 - 30 wirefeeders are fitted with a water-cooled electric motor with disc-shaped rotor. VR 7000 - 11 and VR 7000 - 30 must only be operated in conjunction with an appropriate cooling unit!

**Warning notices  
affixed to the  
machine**

The wirefeeder is fitted with safety symbols on the rating plate. The safety symbols must NOT be removed or painted over. The symbols warn against operating the equipment incorrectly, which can cause serious injury and damage.

IEC 60974-5		EN 50 199		IP 23	
=	U <sub>11</sub>	55 V	I <sub>11</sub>	4 A	
	U <sub>12</sub>	24 V	I <sub>12</sub>	2 A	
⊕	0,5-22 m/min		I <sub>2</sub>	360 A/100%	450 A/60%

CE	⚠	📖
----	---	---

  

Welding is dangerous. The following basic requirements must be met:

- Welders must be sufficiently qualified
- Suitable protective equipment
- Keep all persons not involved in the welding process at a safe distance

Do not use the functions described here until you have read and completely understood all of the following documents:

- these Operating Instructions
- all "Operating Instructions" for the system components, especially the "Safety rules"



*Warning notices on the wirefeeder*

# Options

## „Mode“ switch option

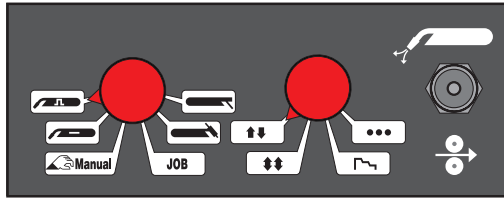

Detailed view of „Mode“ switch option

The „mode“ switch enables the processes and operating modes to be selected on site; the „gas test“ and „feeder inching“ functions can also be carried out on site.



**Note!** The „Mode“ switch option cannot be used:

- if the wirefeeder is fitted with the VR 4000 digital display.
- on the VR 7000 CMT

## VR 4000 Ci control panel option and VR 4000 digital display option

The wirefeeder can be fitted with the following control panels as an alternative to the „Standard“ control panel:

- VR 4000 Ci
- VR 4000 digital display

Please refer to the installation instructions for a detailed description of the optional control panels.

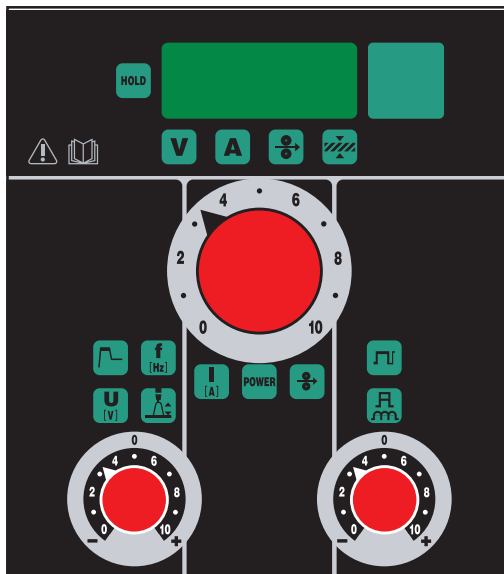

VR 4000 Ci control panel option

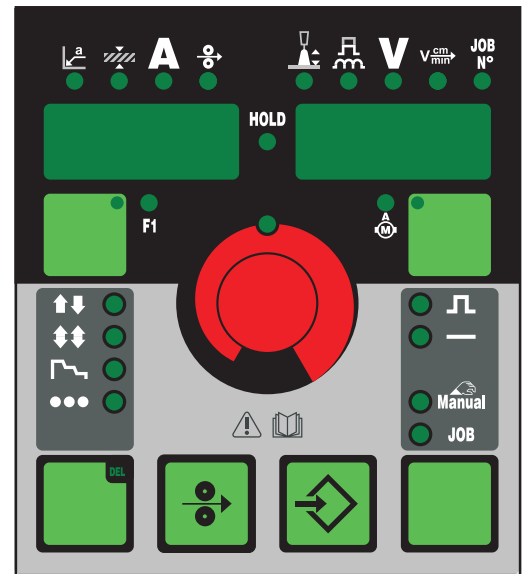

VR 4000 digital display option

**Important!** On the VR 7000 CMT, the optional VR 4000 Ci and VR 4000 control panels are used exclusively to display actual values. Parameters cannot be adjusted via the optional control panels and the RCU 5000i remote control.

**Optional installation and modification sets**

---

**Robacta drive installation set:**

for subsequent installation of a connection socket for the Robacta drive robot welding torch  
standard on the VR 7000 CMT

---

**Push-pull unit installation set:**

for retrofitting a push-pull unit  
standard on the VR 7000 CMT

---

**Digital gas control:**

for retrofitting with the digital gas control

---

**900 A installation set:**

for subsequent modification so that VR 7000 - 11 and VR 7000 - 30 can be used with a welding current of 900 A  
VR 7000 - 11 and VR 7000 - 30 only

---

**Gas economiser valve installation set:**

for retrofitting of a gas economiser

---

**Plastic/metal adapter installation set:**

for subsequent changeover from plastic to metal connection sockets

---

**Gas test/feeder inching installation set:**

for retrofitting of a rocker switch for gas test and feeder inching  
standard on the VR 7000 CMT

---

**Trabant:**

for installing the feeder on the Trabant trolley

---

**Fixable clamping lever installation set:**

for retrofitting of a fixable clamping lever, so that contact pressure cannot be accidentally adjusted

---

**Gas nozzle position search installation set:**

for retrofitting with the gas nozzle position search option (recognises when workpiece makes contact by means of gas nozzle, used mainly in robot welding)

---

**Wire-end connector installation set:**

for retrofitting of wire-end connector option (switching off power source at wire end)

---

**Wire-end monitoring installation set:**

for retrofitting of wire end monitoring (advance warning before end of welding wire)

---

**VR 143-2 intermediate drive adapter installation set:**

for retrofitting an adapter for the VR 143-2 intermediate drive in conjunction with the push-pull unit  
VR 7000, VR 7000 - 11 and VR 7000 - 30 only

---

**Torch blow-off basic installation set:**

for retrofitting with torch blow-off basic option (blowing the welding torch with compressed air during cleaning mode)

---

**Torch blow-off High End installation set:**

for retrofitting with torch blow-off High End option - blowing the welding torch with compressed air (15 bar) during cleaning mode

---

**VR take-up for upright console:**

for take-up of wirefeeder when power source is fastened to an upright console

---

**Optional installation and modification sets**  
(continued)

---

**QuickConnect option**

for simple installation of a wirefeeding hose between external welding wire and wirefeeder 4-roll drive

---

**Wirefeeding hose option**

for protected transport of the wire from external welding wire to wirefeeder 4-roll drive

---



# Controls

## General remarks

Setting parameters at control panels is only possible in manual welding mode. In the automated welding mode or in robot welding, the robot control provides the command values for welding parameters. Specifying command values via control panels is not possible in automated welding mode or in robot welding.

**Important!** Parameters that must be entered at a wirefeeder control panel cannot be changed at the power source. Parameters can only be changed at the wirefeeder.

## Controls



**Warning!** Operating the equipment incorrectly can cause serious injury and damage. Do not use the functions described here until you have read and completely understood all the operating instructions.

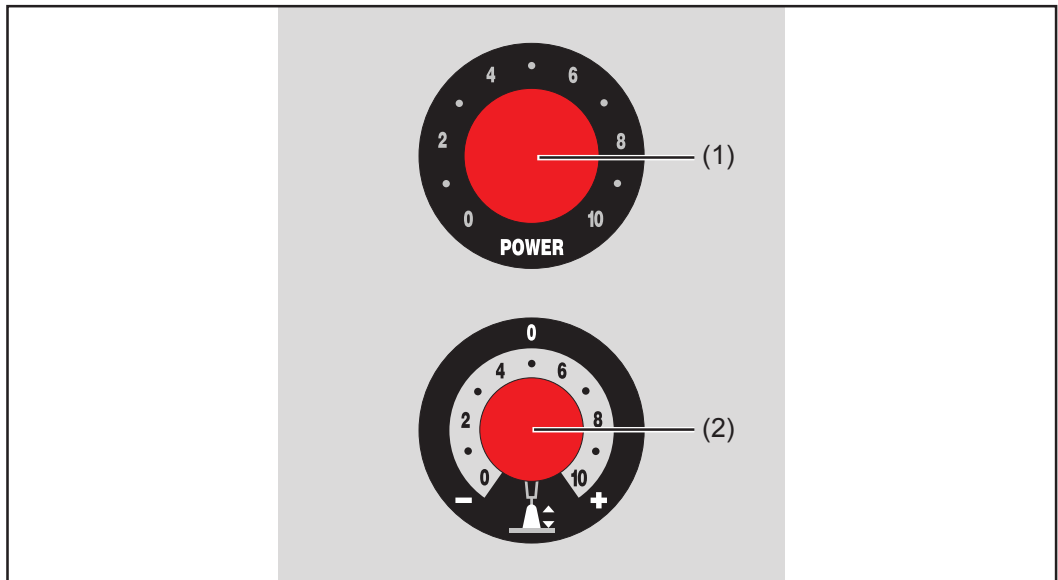

VR 7000 „Standard“ control panel

Item	Function
(1)	<b>Welding power/wirefeed speed adjuster</b> has a different function depending on the process being used:  MIG/MAG pulse synergic welding, MIG/MAG standard synergic welding: setting welding power  MIG/MAG standard manual welding: setting the wirefeed speed
(2)	<b>Arc length/arc force dynamic adjuster</b> has a different function depending on the process being used:  MIG/MAG pulse synergic welding, MIG/MAG standard synergic welding: correcting the arc length  - shorter arc length 0 neutral arc length + longer arc length

- shorter arc length
- 0 neutral arc length
- + longer arc length



**Controls**  
(continued)

MIG/MAG standard manual welding:  
setting the welding voltage

Rod electrode (MMA) welding:  
for influencing the short-circuiting amperage at the instant of droplet transfer

0 soft, low-spatter arc  
100 harder, more stable arc

---



# Connections and mechanical components

## Wirefeeder front

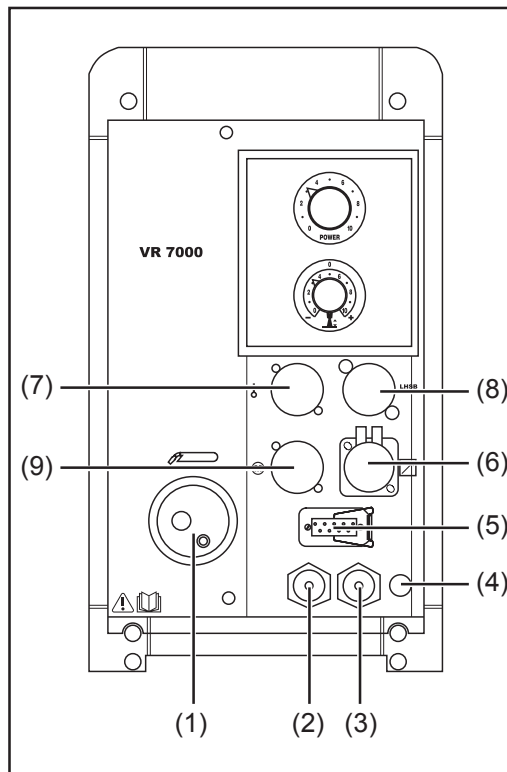

VR 7000 - Front view

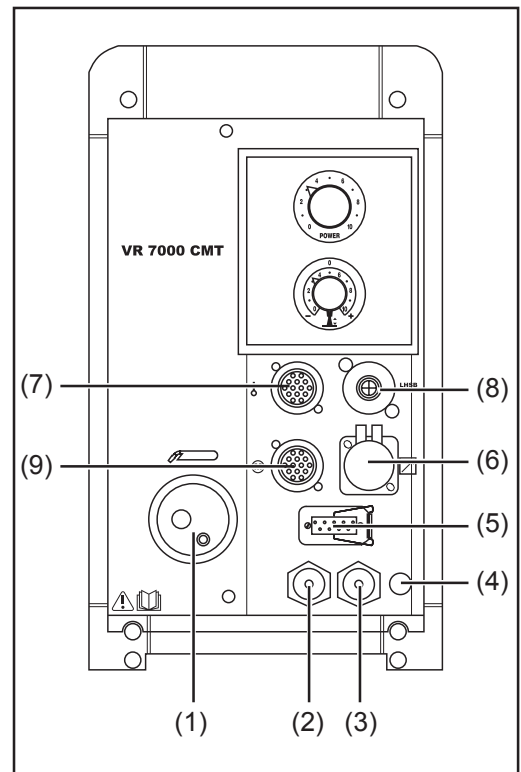

VR 7000 CMT - front view

Item	Description
(1)	Welding torch connection for connecting the welding torch
(2)	Water return connection (red)
(3)	Water flow connection (blue)
(4)	Blanking cover Blow-off HighEnd option
(5)	Torch control connection for connecting the torch control plug
(6)	LocalNet connection standardised connection socket for system extensions (e.g. remote control, JobMaster torch, etc.)
(7)	Blanking cover on VR 7000, VR 7000-11, VR 7000-12, VR 7000-30 Wire buffer connection on VR 7000 CMT 4-pin amphenol socket for connecting the wire buffer
(8)	Blanking cover on VR 7000, VR 7000-11, VR 7000-12, VR 7000-30 LHSB CMT drive unit connection on VR 7000 CMT for connecting the LHSB cable from the torch, incl. power supply of CMT drive unit
(9)	Blanking cover on VR 7000, VR 7000-11, VR 7000-12, VR 7000-30 Robacta drive connection option, 14-pin amphenol socket (standard on the VR 7000 CMT)

## Wirefeeder rear

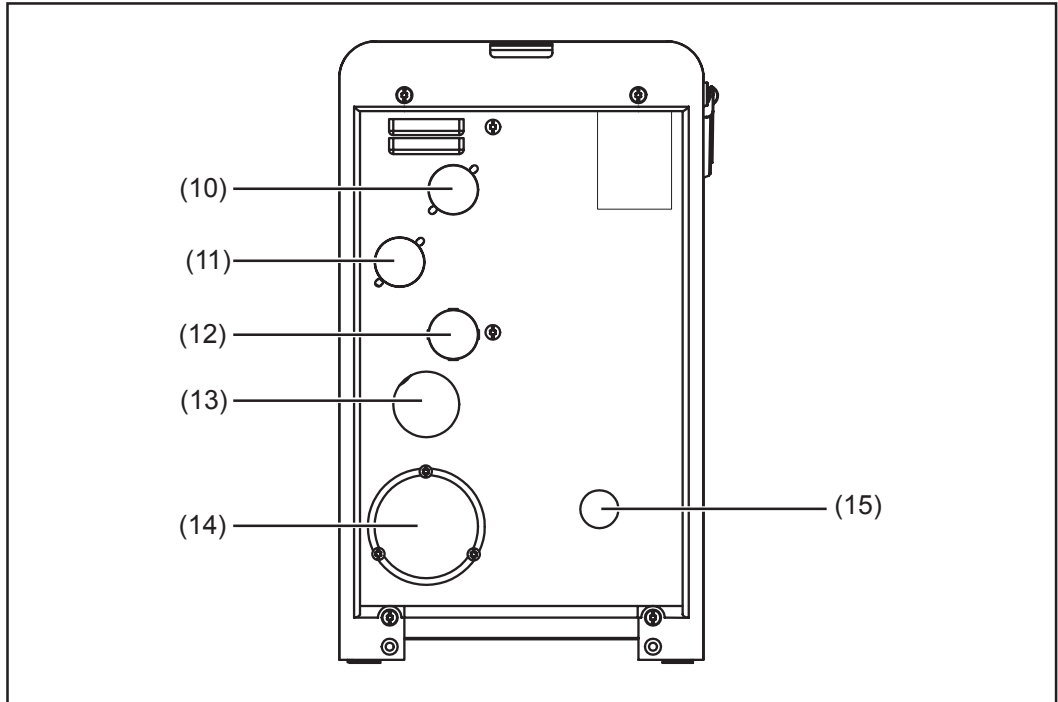

VR 7000, VR 7000 CMT - rear view





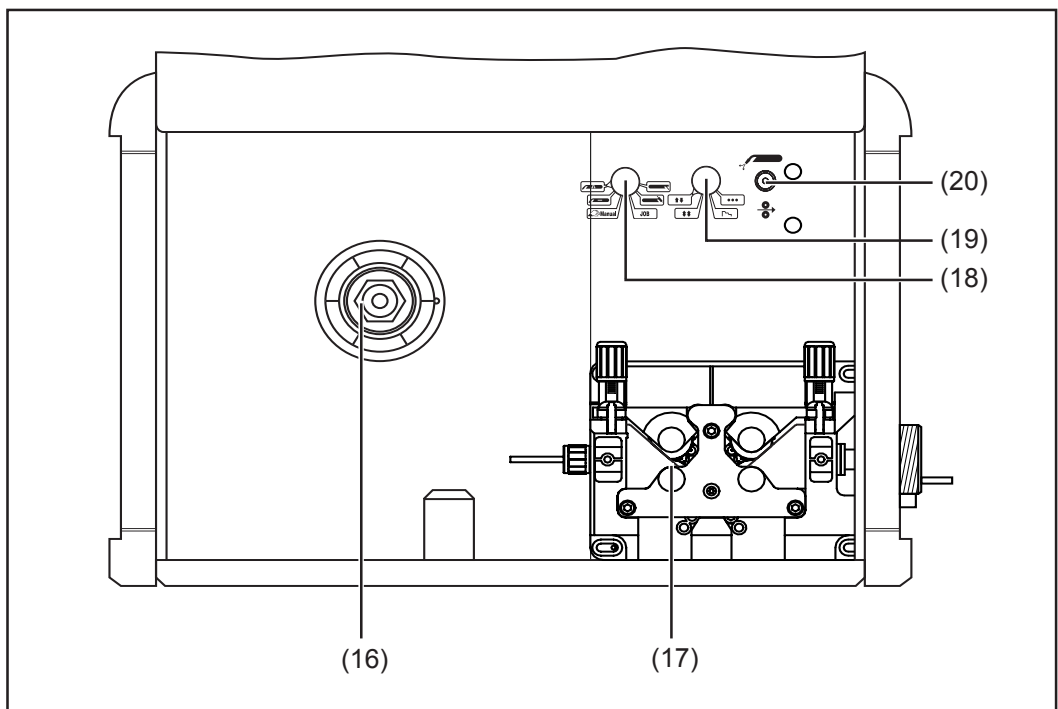





Item	Description
(10)	Blanking cover
(11)	Blanking cover Gas economiser valve option
(12)	Blanking cover Current socket on installation set 900 A option for VR 7000 - 11 and VR 7000 - 30
(13)	Bushing for compressed air
(14)	Bushing for interconnecting hosepack
(15)	Bushing for external welding wire

## Wirefeeder left side



VR 7000, VR 7000 CMT - view of left side

**Wirefeeder left side**  
(continued)

Item	Description
(16)	Holder for braked wirespool for attaching standardised wirespools up to max. 16 kg (35.27 lbs.) and with a maximum diameter of 300 mm (11.81 in.)
(17)	4-roll drive
(18)	Process selector switch <sup>1)</sup> for selecting the following processes:   MIG/MAG pulse synergic welding  MIG/MAG standard synergic welding  MIG/MAG standard manual welding  Welding job  TIG welding with touch-down ignition  Rod electrode (MMA) welding  <b>Important!</b> If the VR 7000 wirefeeder is connected to a TS 4000/5000 power source, MIG/MAG pulse synergic welding is not available.
(19)	Operating mode selector switch <sup>1)</sup> for selecting the following operating modes:   2-step mode  4-step mode  Special 4-step (aluminium welding start-up) mode  Spot welding
(20)	„Feeder inching“/gas test button <sup>1)</sup>  Push button downwards: to feed the welding wire into the torch hosepack with no accompanying flow of gas or current. While the button is being held down, the wirefeeder runs at feeder inching speed.  Push button upwards: to set the required quantity of gas at the pressure regulator. Gas flows out for as long as the button is pushed up.  The gas test/“feeder inching“ button (20) can also be installed as a separate option on VR 7000.

<sup>1)</sup> „Mode selection switch“ option

**Important!** Settings made on the mode selection switch cannot be altered on other controls, e.g.:

- the power-source control panel
- the front side of the wirefeeder
- the remote control

**Wirefeeder right side**

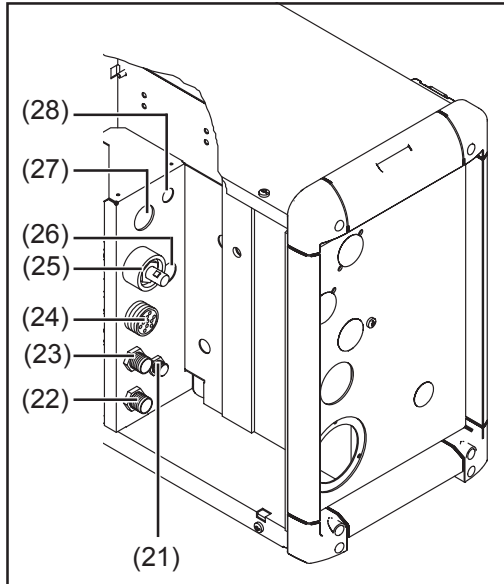

VR 7000 - view of right side

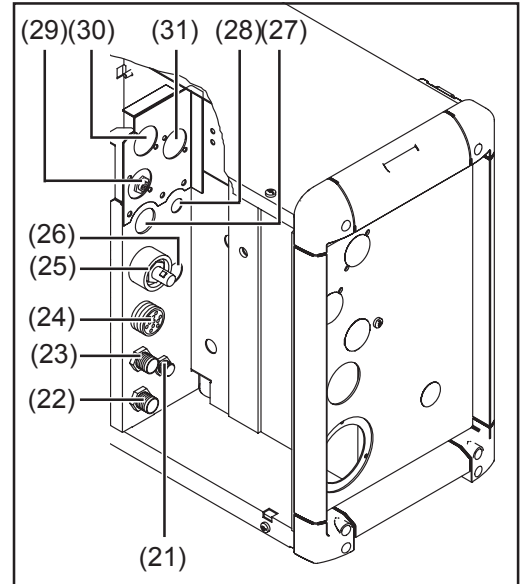

VR 7000 CMT - view of right side

**Item Description**

(21)	Shielding gas connection for interconnecting hosepack
(22)	Water flow (blue) connection for interconnecting hosepack
(23)	Water return (red) connection for interconnecting hosepack
(24)	LocalNet connection for interconnecting hosepack
(25)	(+) - socket with bayonet latch for interconnecting hosepack
(26)	Blanking cover
(27)	Blanking cover
(28)	Blanking cover
(29)	LHSB connection for CMT interconnecting hosepack
(30)	Blanking cover
(31)	Blanking cover

**Wirefeeder underside**

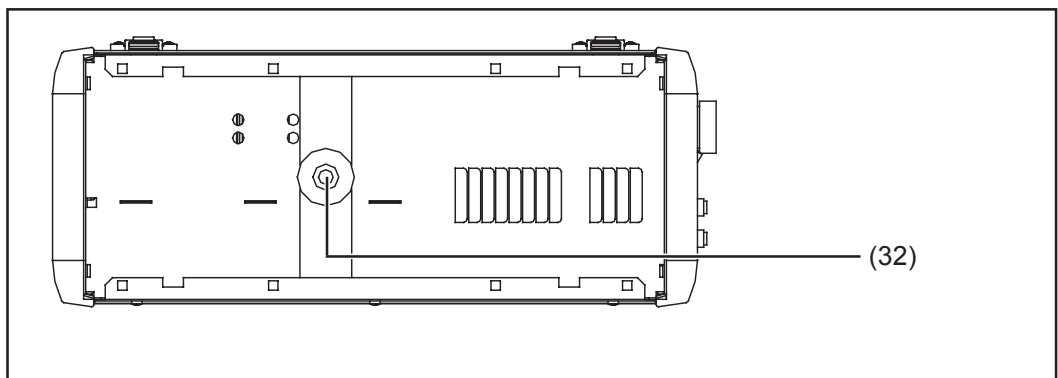

VR 7000 - view from below

**Item Description**

(32)	Socket for swivel pin for placing the wirefeeder on the swivel pin
------	--

# Placing wirefeeder on power source

## General remarks

The VR 7000 can be placed on the power source if a swivel pin receptor is available, e.g.:

- „PickUp“ swivel pin receptor, for use with the „PickUp“ trolley
- „narrow“ swivel pin receptor, for use with an upright console
- „wide“ swivel pin receptor, for use with two screwed upright consoles and two power sources

More detailed information on the swivel pin receptors can be found in the „Swivel pin receptors for upright consoles“ and „PickUp“ operating instructions.

## Placing wirefeeder on power source



**Caution!** Risk of injury and damage from falling wirefeeder. Check that the wirefeeder is securely placed on the swivel pin.

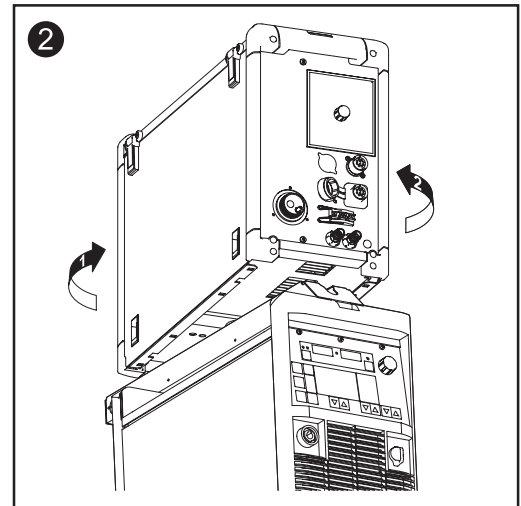
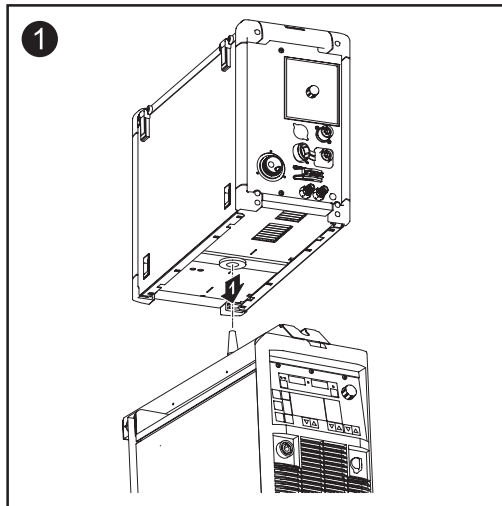

# Connecting wirefeeder to power source

## General remarks

The wirefeeder is connected to the power source using the interconnecting hosepack. For the „CMT“ welding process, a special CMT interconnecting hosepack with additional LHSB cable is required for connecting the VR 7000 CMT to the CMT power source.



## Connecting wirefeeder to power source

**Warning!** Fitting the equipment incorrectly can cause serious injury and damage. Do not carry out the steps described here until you have read and completely understood all the operating instructions.

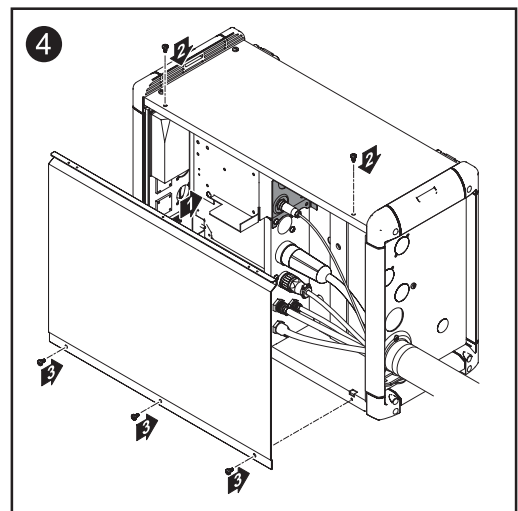
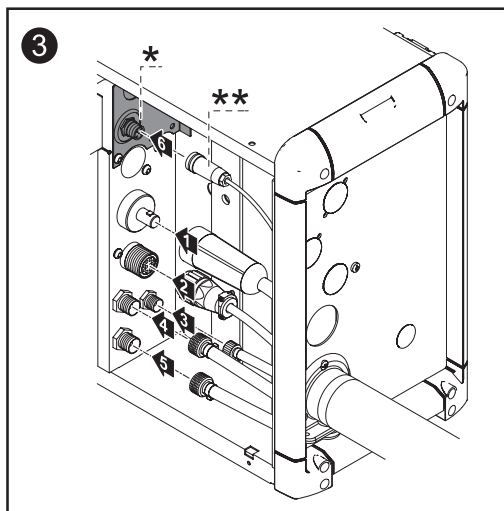
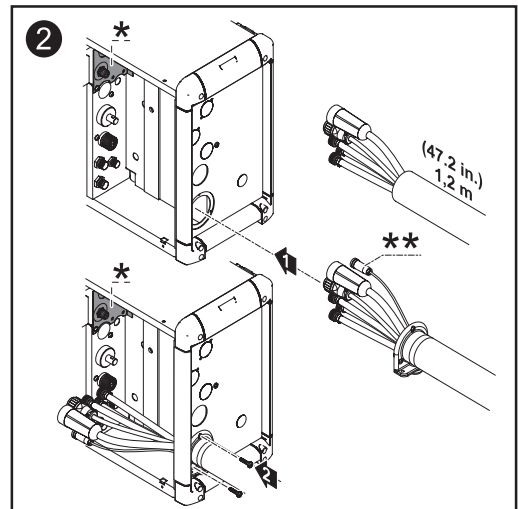
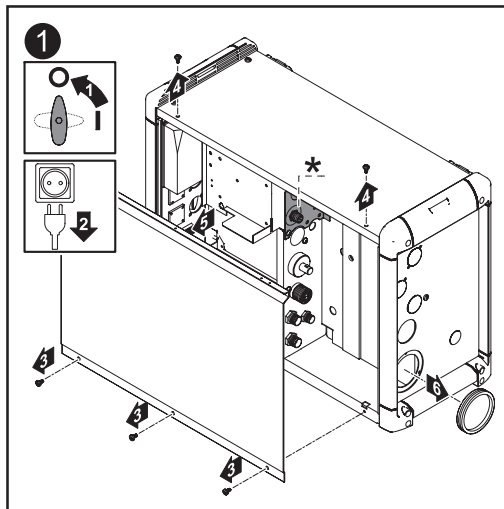

\* On the VR 7000 CMT only

\*\* LHSB cable, on CMT interconnecting hosepack only



**Note!** When connecting the interconnecting hosepack, check that

- all connections are connected properly
- all cables, leads and hosepacks are undamaged and correctly insulated.

# Connecting the welding torch

## Welding torch connections

The following welding torch connections can be connected to VR 7000 wirefeeders:

	Fronius F++	Euro connection	Dinse connection
VR 7000	X	X	X
VR 7000 - 11	X	(X)	-
VR 7000 -30	X	(X)	-
VR 7000 CMT	X	-	-

(X) ... up to a max. of 500 A



**Note!** When using a welding current over 500 A, only operate wirefeeders VR 7000 - 11 and VR 7000 - 30 with Fronius torches that are adequately dimensioned for the welding torch F++ connection.

## Safety



**Note!** When connecting the welding torch, check that

- all connections are connected properly
- all cables, leads and hosepacks are undamaged and correctly insulated.

## Connecting MIG/MAG manual welding torch

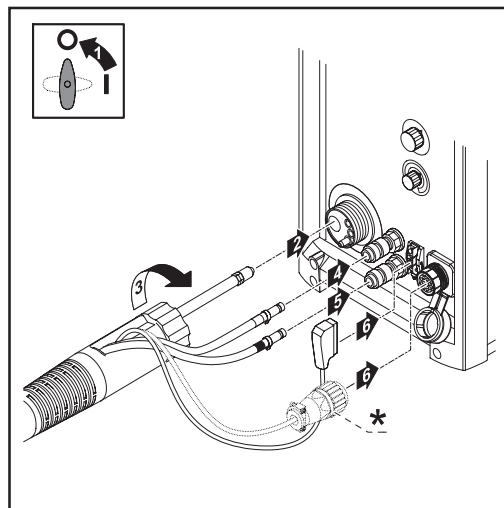

\* The MIG/MAG manual welding torch control plug comes in two versions:  
a) as a „Tuchel“ plug  
b) as a LocalNet plug, e.g. on Job-Master welding torches



**Connecting the MIG/MAG robot welding torch, connecting the MIG/MAG machine welding torch**

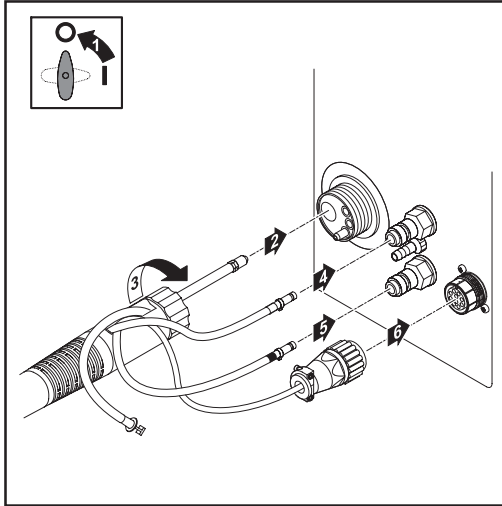

MIG/MAG robot welding torch (e.g. Robacta Drive)

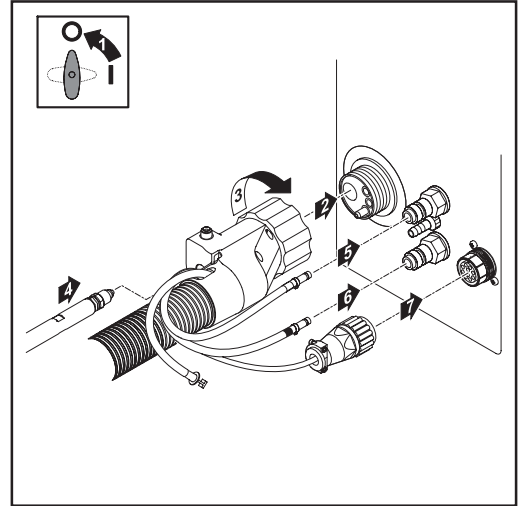

MIG/MAG robot welding torch with external wirefeeding hose (e.g. Robacta Drive ext. DFS)

**Connecting the CMT drive unit**

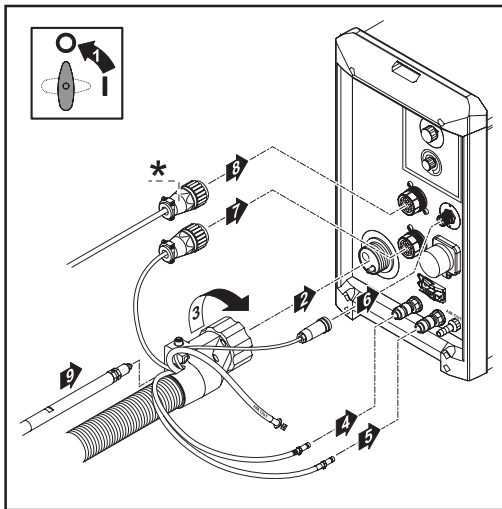

\* Control plug for wire buffer



# Inserting/changing feed rollers

**General remarks** In order to achieve satisfactory wire feed, the feed rollers must be suitable for the diameter and alloy of the wire being welded.

**Important!** Use only feed rollers that match the welding wire.

An overview of the feed rollers available and their possible areas of use can be found in the spare parts lists.

**USA wirefeeders** In USA, wirefeeders are not delivered with feed rollers. After inserting the wirepool the feed rollers must be inserted in the wirefeeder.

## Inserting/changing feed rollers

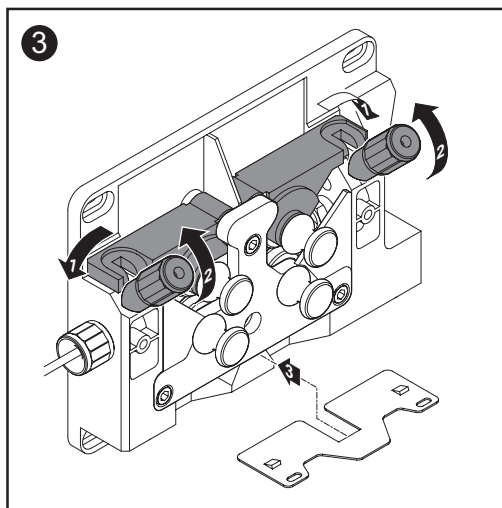
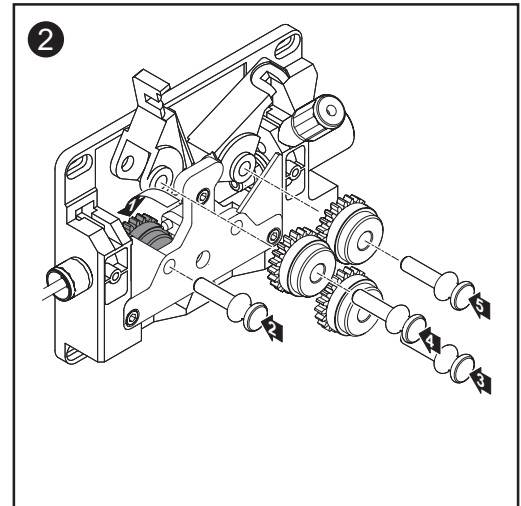
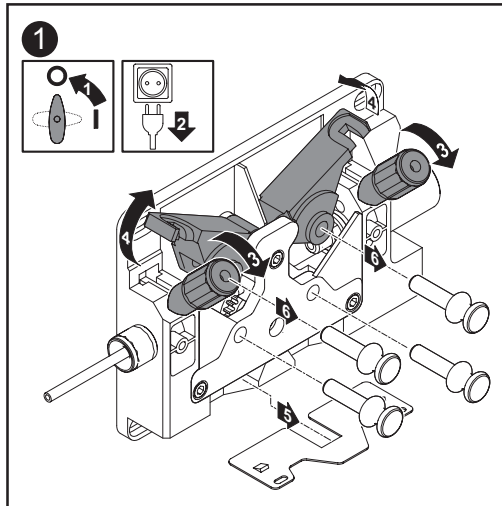

# Inserting the wirepool, inserting the basket-type spool

## Safety

**Caution!** Risk of injury from springiness of spooled welding wire. While inserting the wirepool/basket-type spool, hold the end of the welding wire firmly to avoid injuries caused by the wire springing back.

**Caution!** Risk of injury from falling spool. Make sure that the wirepool or basket spool adapter with spool is fitted securely to the wirepool holder.

## Inserting the wirepool

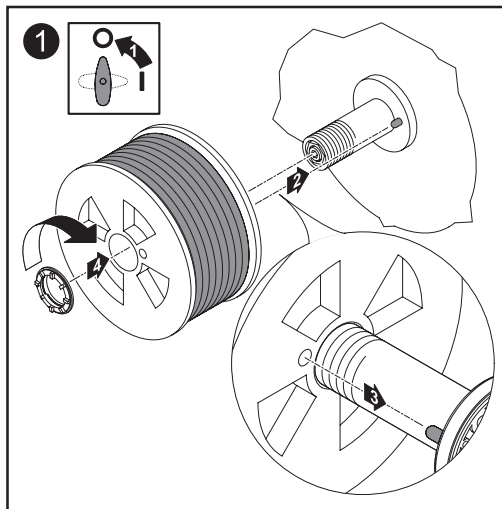

## Inserting basket-type spool

**Note!** When working with basket-type spools, use only the basket spool adapter supplied with the wirefeeder. USA wirefeeders are supplied without basket spool adapters.

**Caution!** Risk of injury from falling spool. Place basket-type spool on the adapter provided in such a way that the bars on the spool are inside the adapter guideways.

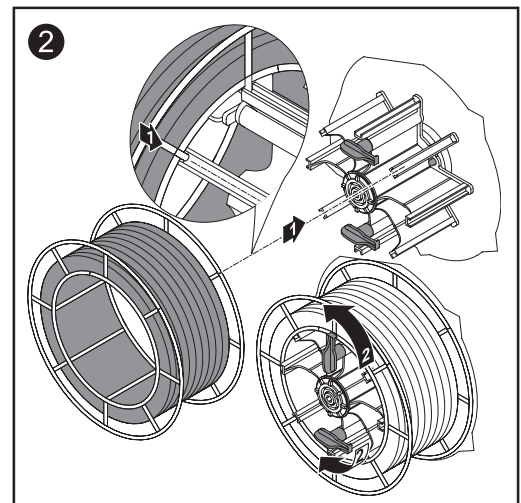
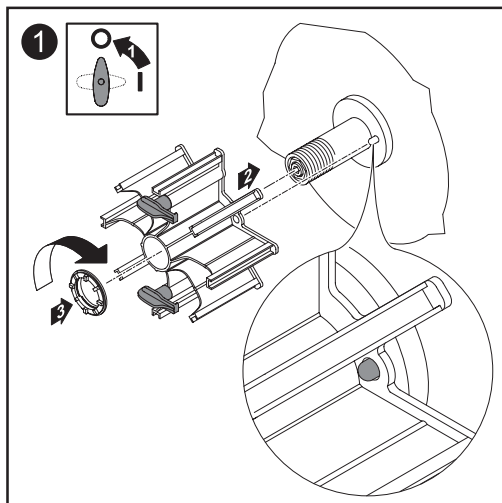

# Feeding in the welding wire

## Feeding in the welding wire

**Caution!** Risk of injury from springiness of spooled welding wire. While inserting the welding wire into the 4-roller drive, hold the end of the welding wire firmly to avoid injuries caused by the wire springing back.

**Caution!** Risk of damage to the welding torch from sharp end of welding wire. Deburr the end of the welding wire well before feeding in.

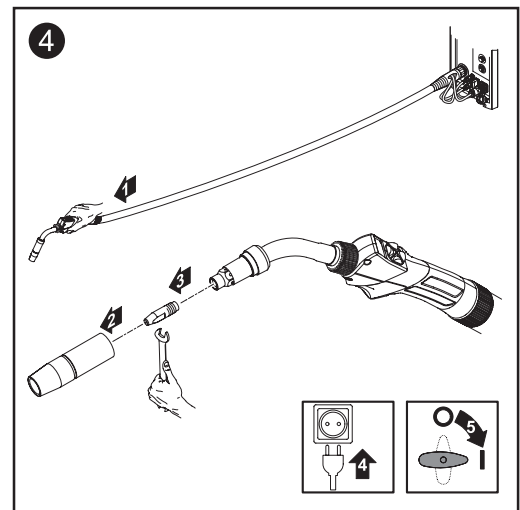
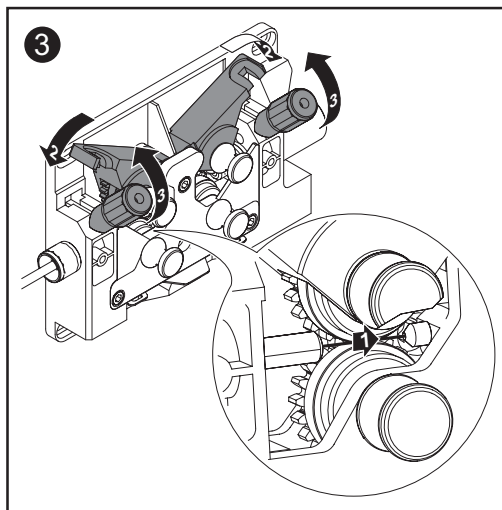
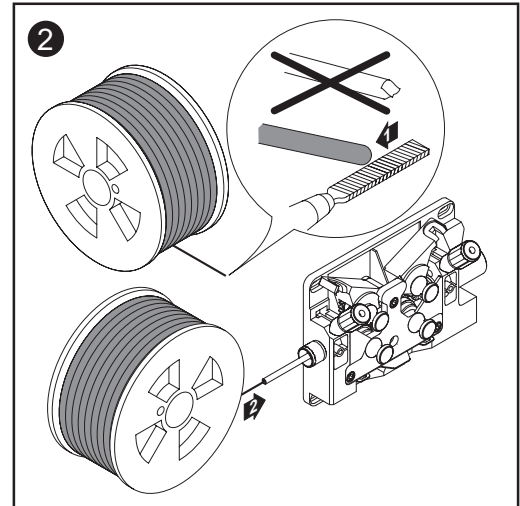
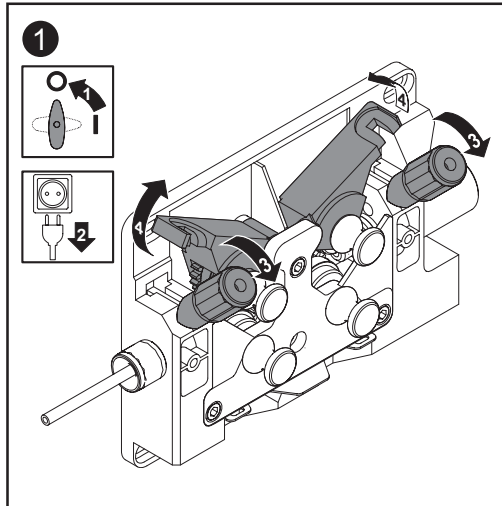

**Feeding in the welding wire**  
(continued)

**Caution!** Danger from welding wire emerging at speed. Keep the welding torch away from face and body when pressing the „Feeder inching“ button.

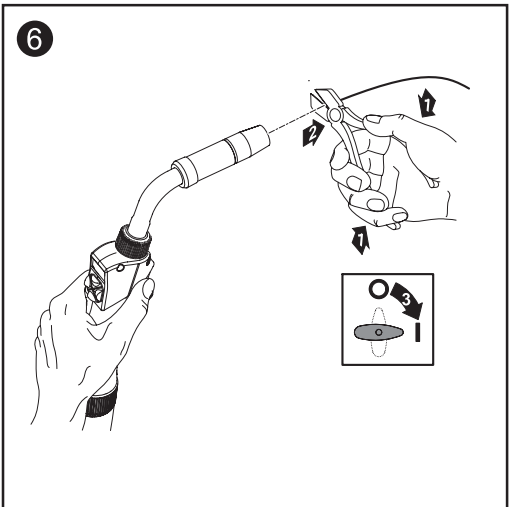
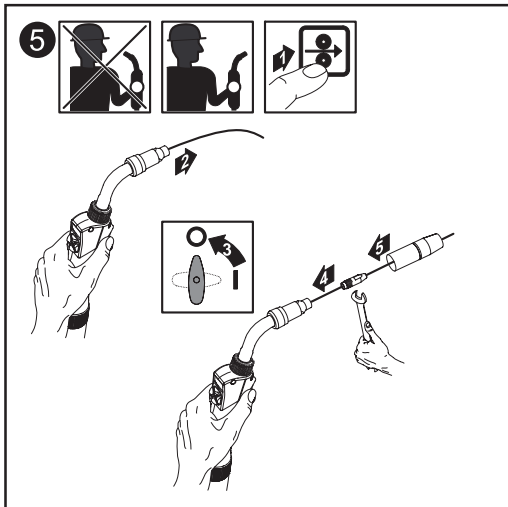

**Setting the contact pressure**

**Note!** Adjust contact pressure in such a way that welding wire is not deformed, but it is nevertheless ensured that the wire is transported properly.

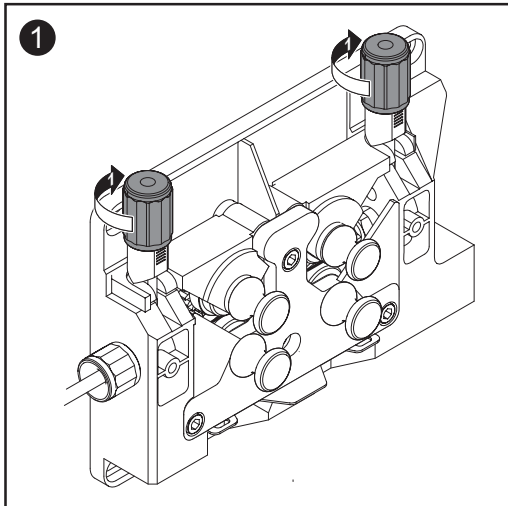

Contact pressure reference values			
	Semi-cylindrical rollers	Trapeze rollers	Plastic rollers
Aluminium	1.5	-	3.5 - 4.5
Steel	3 - 4	1.5	-
CrNi	3 - 4	1.5	-



# Adjusting the brake

## General remarks

**Important!** After releasing the torch trigger the wirespool should stop unreeling. Adjust brake if necessary.

## Adjusting the brake

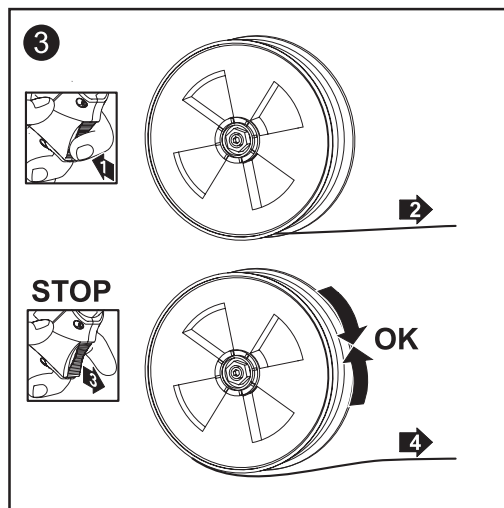
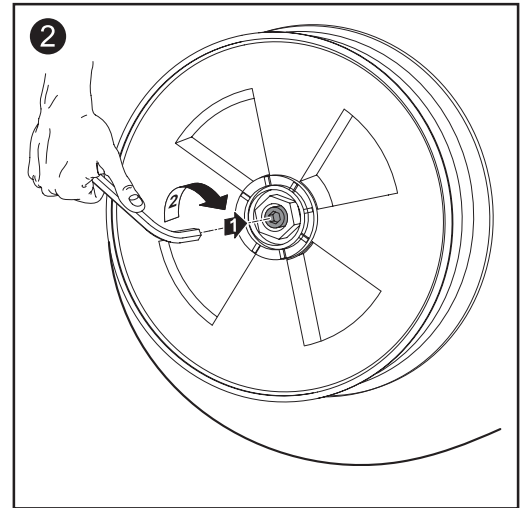
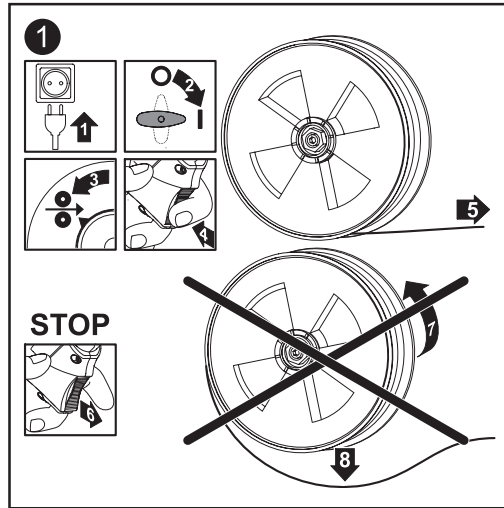

## Design of the brake

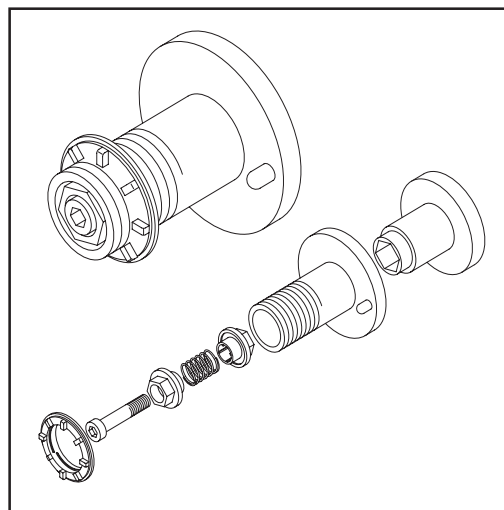

**Warning!** Fitting the equipment incorrectly can cause serious injury and damage.

- Do not dismantle the brake
- Maintenance and servicing of brakes to be carried out by trained, qualified personnel only

The brake is only available as a complete unit. This illustration is for information purposes only.

# Fitting wirefeeding hose for external welding wire

- General remarks** The wirefeeding hose option serves to protect the external welding wire while it is being conveyed to the wirefeeder 4-roll drive.
- The wirefeeding hose is available in two versions:
- For steel (blue)
  - For aluminium (white)

## Fitting wirefeeding hose for external welding wire

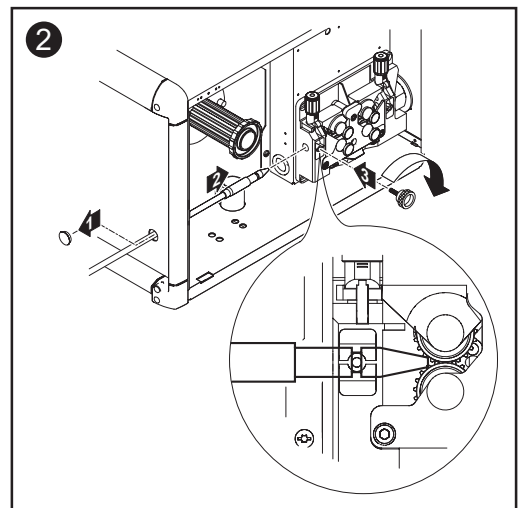
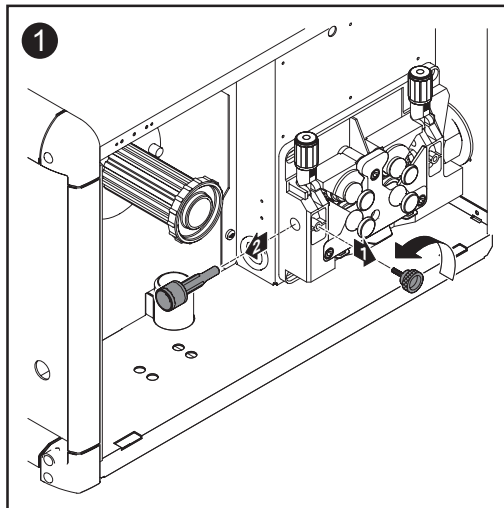

# Commissioning

## General remarks



**Warning!** Operating the equipment incorrectly can cause serious injury and damage. Do not use the functions described here until you have read and completely understood all of the following documents:

- these Operating Instructions
- all operating instructions for the system components, especially the "Safety rules"

The wirefeeder is commissioned by pressing the torch trigger (for manual applications) or by means of a welding start-up signal (for automatic applications).

## Requirements

When commissioning the wirefeeder, the following requirements must be met:

- Wirefeeder connected to the power source using the interconnecting hosepack
- Welding torch connected to wirefeeder
- Feed rollers inserted in the wirefeeder
- Wirespool or basket spool and adapter inserted in the wirefeeder
- Welding wire fed in
- Braking force set
- Feed roller contact pressure set
- All covers closed, all side panels in place, all protection devices intact and in their proper place



# Care, maintenance and disposal

**General remarks** Under normal operating conditions the wirefeeder requires only a minimum of care and maintenance. However, it is vital to observe some important points to ensure the welding machine remains in a usable condition for many years.



**Warning!** An electric shock can be fatal. Before opening up the machine

- Switch the mains switch to the "O" position
- Unplug the machine from the mains
- Put up an easy-to-understand warning sign to stop anybody inadvertently switching it back on again
- Using a suitable measuring instrument, check to make sure that electrically charged components (e.g. capacitors) have been discharged

**Every start-up**

- Check welding torch, interconnecting cable and grounding (earthing) connection for signs of damage
- Perform a visual check on the feed rollers and wire for signs of damage
- Check wirefeeder rolls' contact pressure and adjust if necessary
- Check brake and adjust if necessary

**Every 6 months**

- Dismantle machine side panels and clean machine inside with dry reduced compressed air



**Note!** Risk of damage to electronic components. Do not bring the air nozzle too close to the electronic components.

**Disposal** Dispose of in accordance with the applicable national and local regulations.

# Technical data

## VR 7000

Supply voltage (supply from the power source)	55 V DC
Nominal current	4 A
Wire speed	0.5 -22 m/min 19.69 - 866.14 ipm.
Protection	IP 23
Measurements l x b x h	640 x 260 x 430 mm 25.20 x 10.24 x 16.93 in.
Weight	18 kg 39.68 lbs.
Wirespool types	all standardised spools
max. permitted wirespool weight	16 kg 35.27 lbs.
Wirespool diameter	300 mm 11.81 in.
Wire diameter	0.8 -1.6 mm 0.03 - 0.06 in.
Drive	4-roll drive
Maximum shielding gas pressure	7 bar 101 psi.
Coolant	Original Fronius coolant
Maximum coolant pressure	6 bar 87 psi.
LocalNet data rate	57600 baud
LHSB connection	-

## VR 7000 - 11

Supply voltage (supply from the power source)	55 V DC
Nominal current	4 A
Wire speed	0.5 -11 m/min 19.69 -433.07 ipm.
Protection	IP 23
Measurements l x b x h	640 x 260 x 430 mm 25.20 x 10.24 x 16.93 in.
Weight	19 kg 41.89 lbs.
Wirespool types	all standardised spools
max. permitted wirespool weight	16 kg 35.27 lbs.
Wirespool diameter	300 mm 11.81 in.
Wire diameter	0.8 - 3.2 mm 0.03 - 0.13 in.
Drive	4-roll drive, water-cooled electric motor with disc-shaped rotor
Maximum shielding gas pressure	7 bar 101 psi.
Coolant	Original Fronius coolant

**VR 7000 - 11**  
(continued)

Maximum coolant pressure	6 bar 87 psi.
LocalNet data rate	57600 baud
LHSB connection	-

**VR 7000 -30**

Supply voltage (supply from the power source)	55 V DC
Nominal current	4 A
Wire speed	0.5 -30 m/min 19.69 -1181.10 ipm.
Protection	IP 23
Measurements l x b x h	640 x 260 x 430 mm 25.20 x 10.24 x 16.93 in.
Weight	19 kg 41.89 lbs.
Wirespool types	all standardised spools
max. permitted wirespool weight	16 kg 35.27 lbs.
Wirespool diameter	300 mm 11.81 in.
Wire diameter	0.8 -1.6 mm 0.03 - 0.06 in.
Drive	4-roll drive, water-cooled electric motor with disc-shaped rotor
Maximum shielding gas pressure	7 bar 101 psi.
Coolant	Original Fronius coolant
Maximum coolant pressure	6 bar 87 psi.
LocalNet data rate	57600 baud
LHSB connection	-

**VR 7000 CMT**

Supply voltage (supply from the power source)	55 V DC
Nominal current	4 A
Wire speed	0.5 -22 m/min 19.69 - 866.14 ipm.
Protection	IP 23
Measurements l x b x h	640 x 260 x 430 mm 25.20 x 10.24 x 16.93 in.
Weight	18 kg 39.68 lbs.
Wirespool types	all standardised spools
max. permitted wirespool weight	16 kg 35.27 lbs.
Wirespool diameter	300 mm 11.81 in.
Wire diameter	0.8 -1.2 mm 0.03 - 0.05 in.
Drive	4-roll drive



**VR 7000 CMT**  
(continued)

Maximum shielding gas pressure	7 bar 101 psi.
Coolant	Original Fronius coolant
Maximum coolant pressure	6 bar 87 psi.
LocalNet data rate	57600 baud
LHSB data rate	10 MBaud
LHSB interconnecting hosepack connection	standard
LHSB CMT drive unit connection	standard
Supply voltage for CMT drive unit	24 V DC, 100 mA
Wire buffer connection	standard
Supply voltage for wire buffer	24 V DC, 40 mA

Ⓓ Ersatzteilliste

ⒼⒷ Spare Parts List

Ⓕ Liste de pièces de rechange

Ⓘ Lista parti di ricambio

Ⓔ Lista de repuestos

⒫ Lista de peças sobresselentes

ⒹⒻ Onderdelenlijst

Ⓓ Reservdeliste

ⒸⒹ Seznam náhradních dílů

ⒹⒶ Список запасных частей

VR 7000 4R/G/W/Z  
 VR 7000 4R/G/W/F++  
 VR 7000 4R/G/W/E  
 VR 7000 4R/G/W/F++  
 VR 7000 4R/G/W/E  
 VR 7000 Pipe 4R/G/W/F++

4,045,832  
 4,045,832,000  
 4,045,832,001  
 4,045,832,800 US  
 4,045,832,801 US  
 4,045,832,809

VR 7000-30 4R/G/W/F++  
 VR 7000-30 4R/G/W/E  
 VR 7000-11 4R/G/W/F++  
 VR 7000-11 4R/G/W/E  
 VR 7000-CMT 4R/G/W/F++  
 VR 7000-CMT 4R/G/W/F++

4,045,833,000  
 4,045,833,001  
 4,045,904,000  
 4,045,904,001  
 4,045,963,000  
 4,045,963,800

\* gewünschte Länge angeben  
 \* Specify the length required  
 \* Indiquer la longueur désirée  
 \* Indicar la longitud deseada  
 \* Indicare la lunghezza desiderata  
 \* indicar o comprimento desejado  
 \* uved'te požadovanou délku

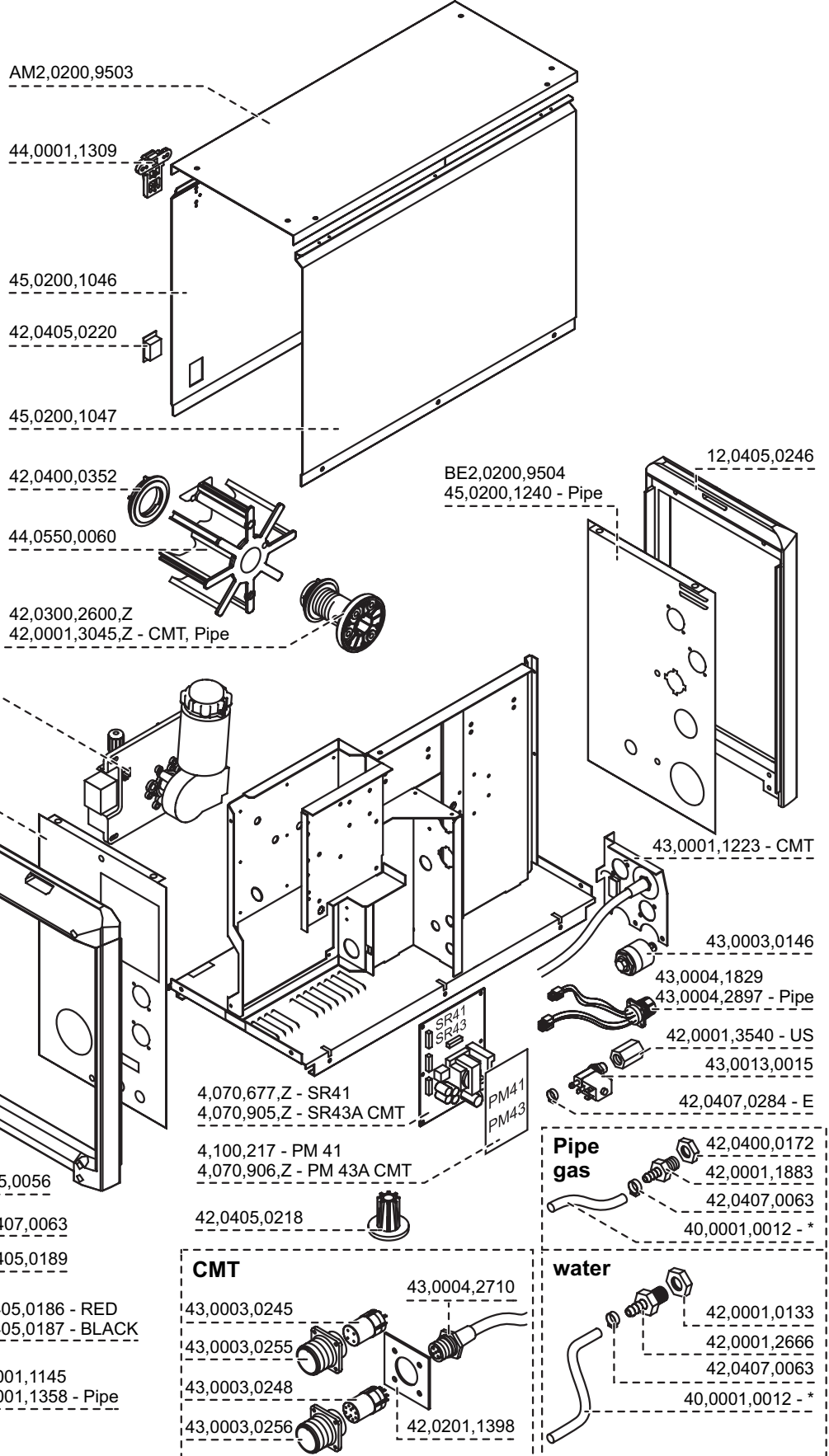

VR 7000

Ersatzteilliste / Spare parts list / Listes de pièces de rechange / Lista de repuestos / Lista de peças sobresselentes / Lista dei Ricambi

1/1

**Motorplate 42V 4R**

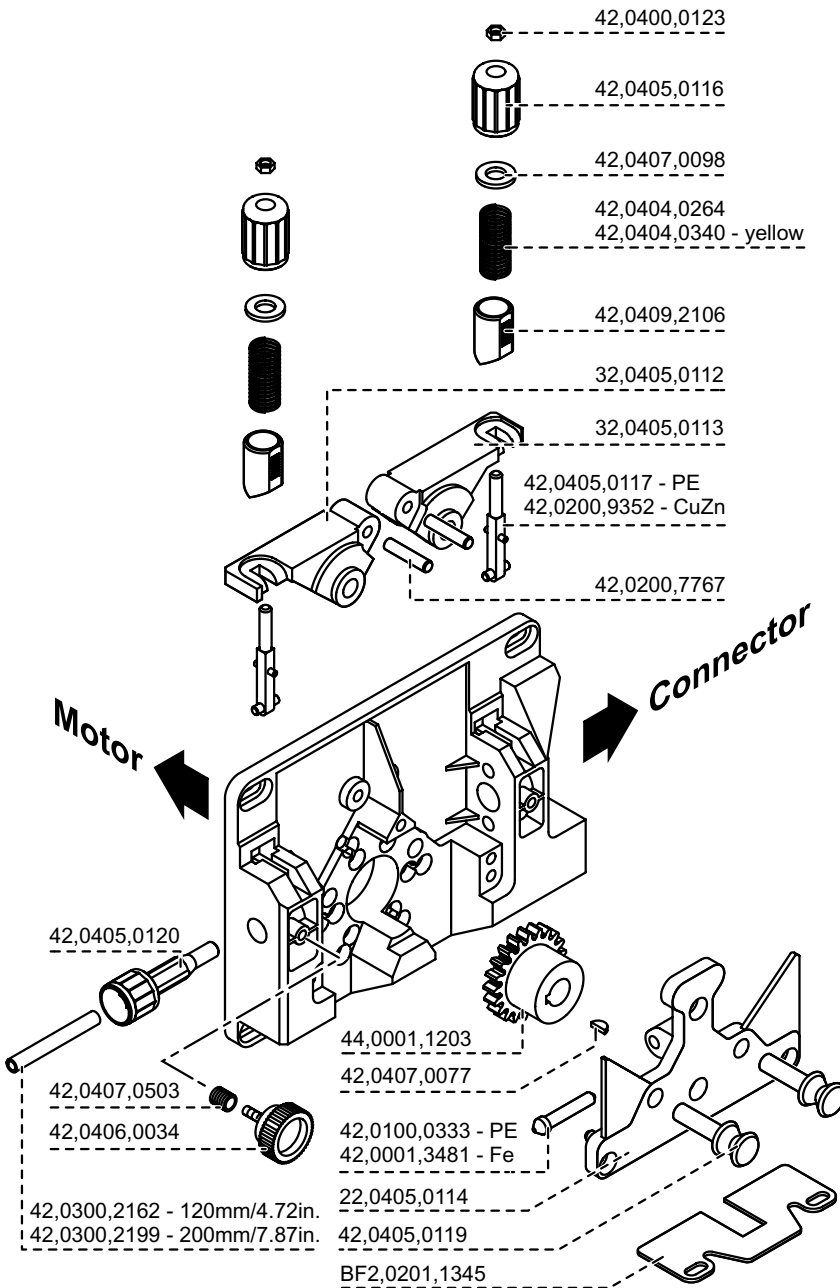

**Connector**

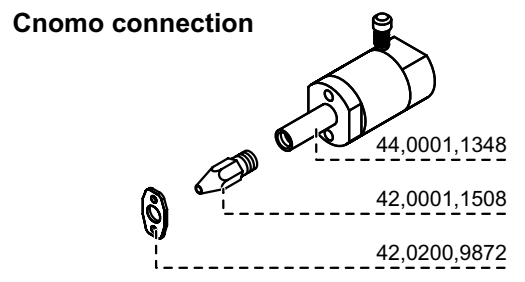
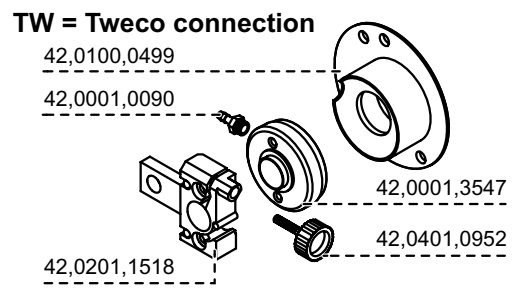
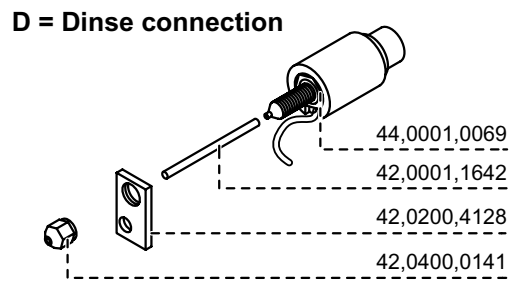
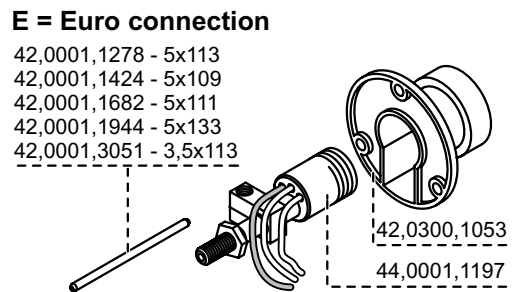
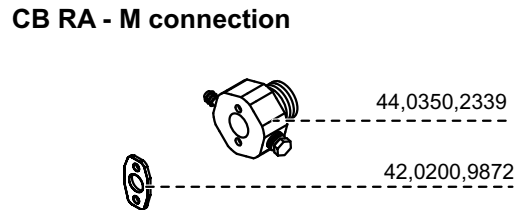
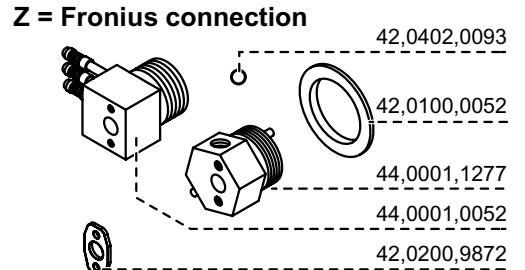

**Motorplate 42V 4R**

Ersatzteilliste / Spare parts list / Listes de pièces de rechange / Lista de repuestos / Lista de peças sobresselentes / Lista dei Ricambi

**Motorplate 42V 4R**

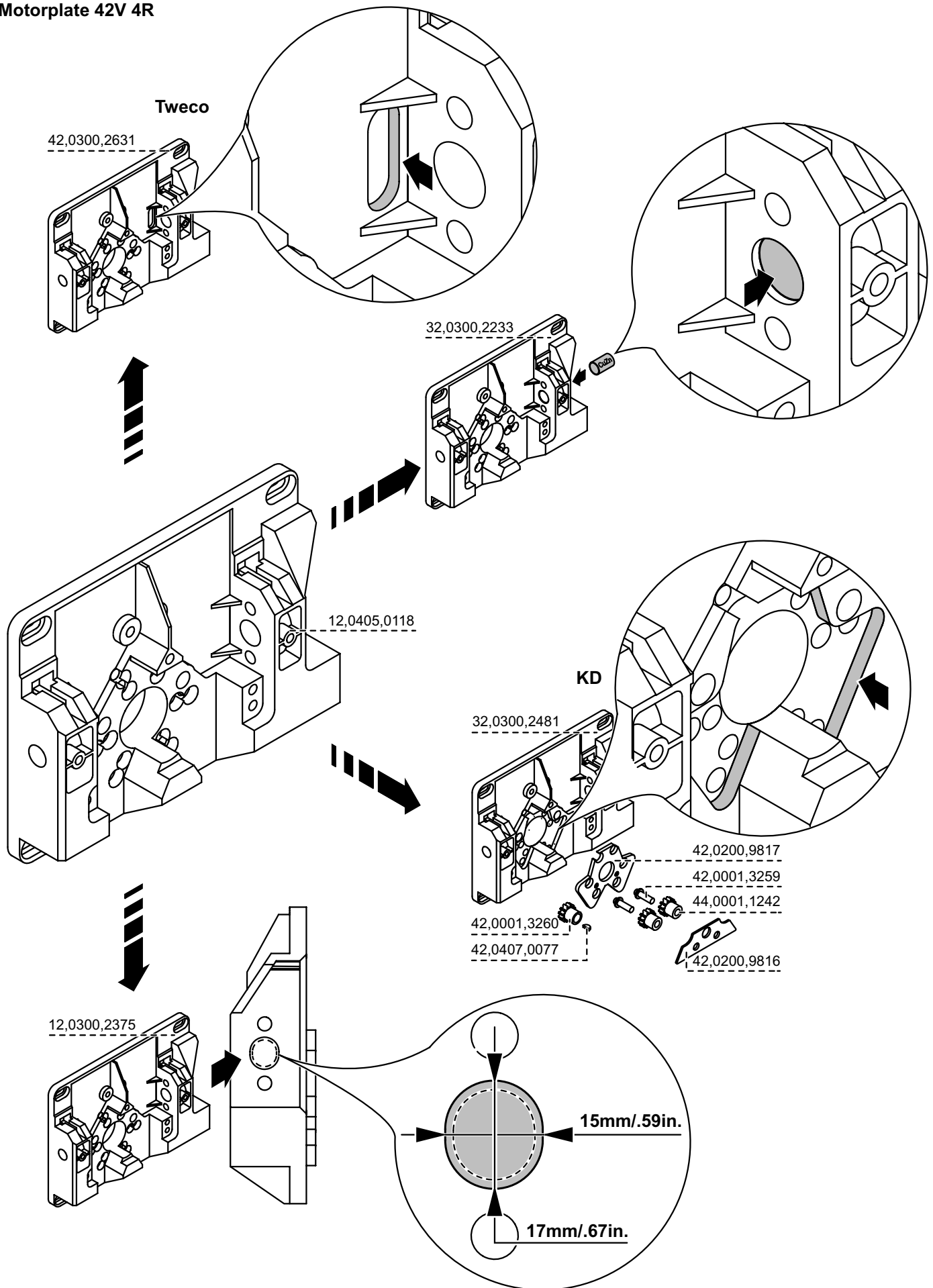

**Motorplate 42V 4R**

Ersatzteilliste / Spare parts list / Listes de pièces de rechange / Lista de repuestos / Lista de peças sobresselentes / Lista dei Ricambi



**Motorplate 42V 4R**

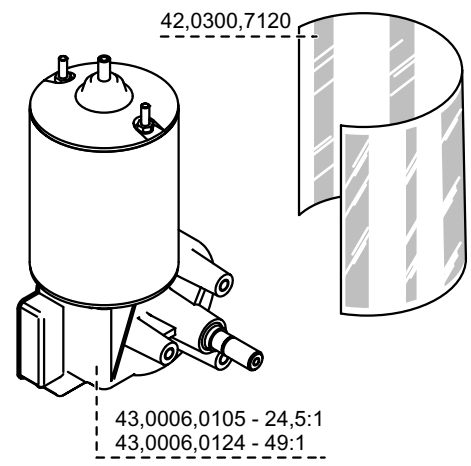
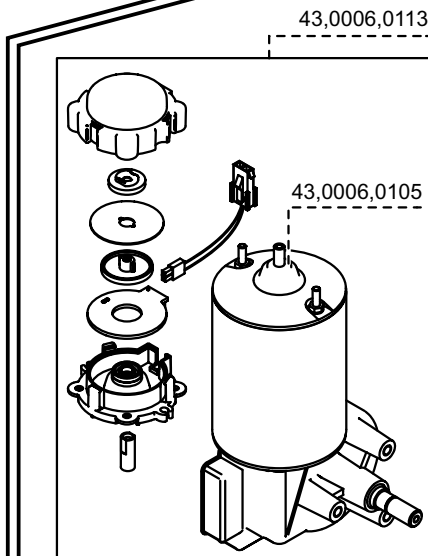
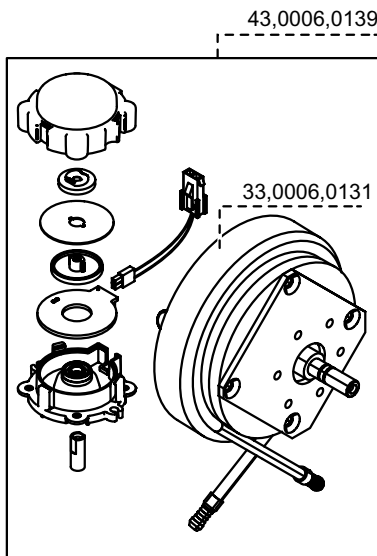
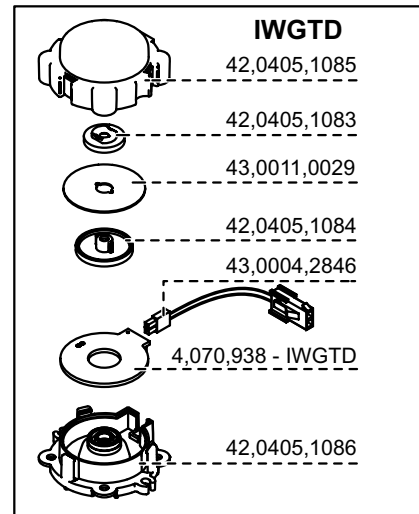
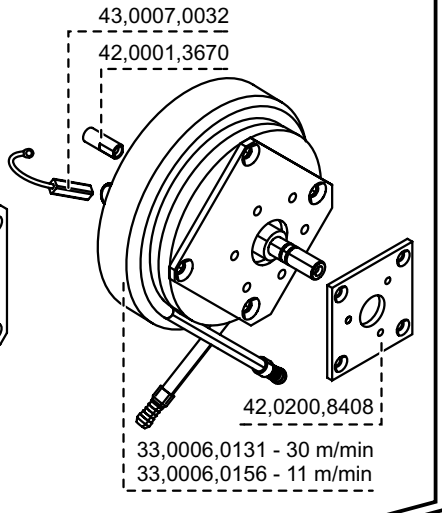
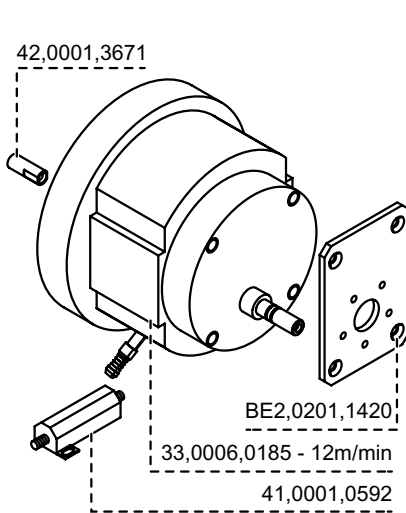
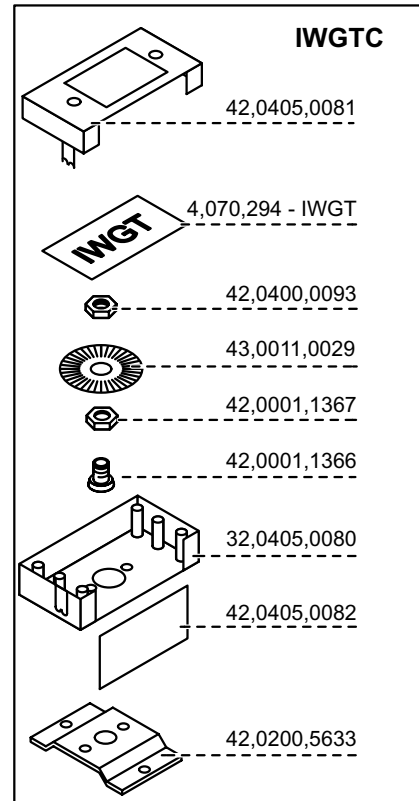
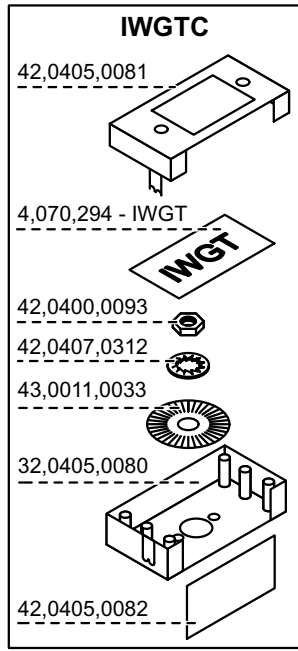
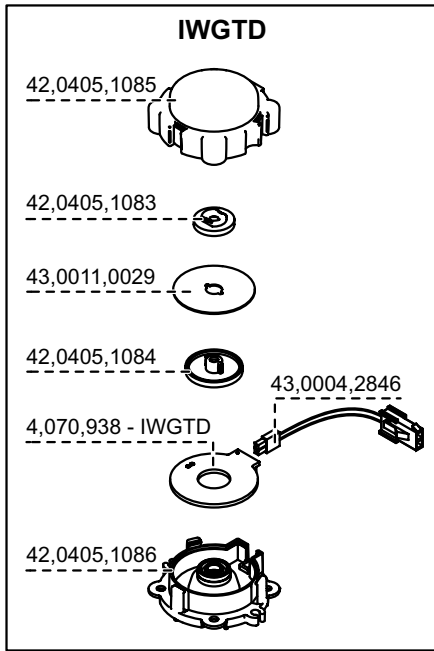

**Motor**



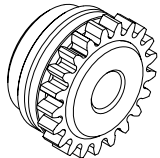

**Motorplate 42V 4R**

Ersatzteilliste / Spare parts list / Listes de pièces de rechange / Lista de repuestos / Lista de peças sobresselentes / Lista dei Ricambi

**Standard**



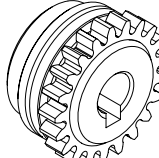

mm / Inch	T	H	R
0,6 / .023	42,0001,1776	-	-
0,8 / .030	42,0001,1584	42,0001,1612	-
0,9 / .035	42,0001,3275	42,0001,1612	-
1,0 / .040	42,0001,1585*	42,0001,1613	-
1,2 / .045	42,0001,1361	42,0001,0385	42,0001,0404
1,4 / .052	42,0001,3570	42,0001,3053	-
1,6 / 1/16	42,0001,1362*	42,0001,0386	42,0001,0352
2,0 / 5/64	42,0001,1575*	42,0001,1608	42,0001,0353
2,4 / 3/32	-	42,0001,1656	42,0001,0354
2,8 / 7/64	-	-	42,0001,0433
3,2 / 1/8	-	42,0001,1838	42,0001,0402



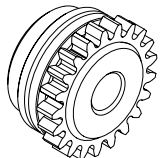

mm / Inch	T	H	R
0,6 / .023	42,0001,1438	-	-
0,8 / .030	42,0001,1582	42,0001,1610	-
0,9 / .035	-	42,0001,1610	-
1,0 / .040	42,0001,1583*	42,0001,1611	-
1,2 / .045	42,0001,1321	42,0001,0382	42,0001,0403
1,6 / 1/16	42,0001,1322*	42,0001,0383	42,0001,0378
2,0 / 5/64	42,0001,1574*	42,0001,1609	42,0001,0379
2,4 / 3/32	-	42,0001,1655	42,0001,0380
2,8 / 7/64	-	-	42,0001,0432
3,2 / 1/8	-	42,0001,1837	42,0001,0401

**Profi**



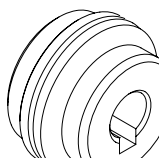



mm / Inch	T	H	R
1,0 / .040	44,0001,1227*	44,0001,1184	-
1,2 / .045	44,0001,1200	44,0001,1185	-
1,6 / 1/16	44,0001,1228*	44,0001,1209	-
1,8 / 9/128	-	44,0001,1296	-



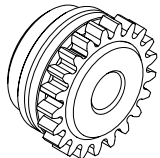



mm / Inch	T	H	R
0,8 / .030	42,0001,2767	-	-
0,9 / .035	42,0001,3591	-	-
1,0 / .040	42,0001,2824*	-	-

**Isolated**

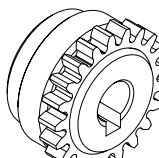
mm / Inch	T	H	R
1,0 / .040	44,0001,1151*	44,0001,0869	-
1,2 / .045	44,0001,1168	44,0001,0823	-
1,6 / 1/16	44,0001,0910*	44,0001,0907	-
2,4 / 3/32	-	44,0001,1265	-

	
44,0001,0683	44,0001,1203

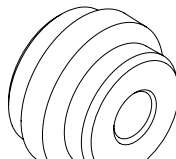

	Standard	Profi	Isolated
	42,0001,1732	44,0001,1221	44,0001,1169

- (D)** \* Nicht geeignet für Schweißdrähte deren Durchmesser nur in inch angegeben ist.
- (GB)** \* Not suited for welding wires with a diameter given in inches only.
- (F)** \* Ne convient pas pour fils soudage dont le diamètre n'est indiqué qu'en pouces.
- (I)** \* Non adatto per fili di apporto il cui diametro sia riportato solo in pollici.
- (E)** \* No sirve para alambres de aportación cuyo diámetro está indicado únicamente en pulgadas.
- (P)** \* Não adequado para fios de soldadura cujo diâmetro esteja indicado apenas em polegadas.
- (CZ)** \* Není vhodný pro svařovací dráty, jejichž průměr byl uveden pouze v palcích.

W	1,2m	70mm <sup>2</sup>	4,047,260
W	1,6m	70mm <sup>2</sup>	4,047,324
W	5,0m	70mm <sup>2</sup>	4,047,261
W	10m	70mm <sup>2</sup>	4,047,262
W	15m	70mm <sup>2</sup>	4,047,290
W	20m	70mm <sup>2</sup>	4,047,277
G	1,2m	70mm <sup>2</sup>	4,047,287
G	5,0m	70mm <sup>2</sup>	4,047,288
G	10m	70mm <sup>2</sup>	4,047,289

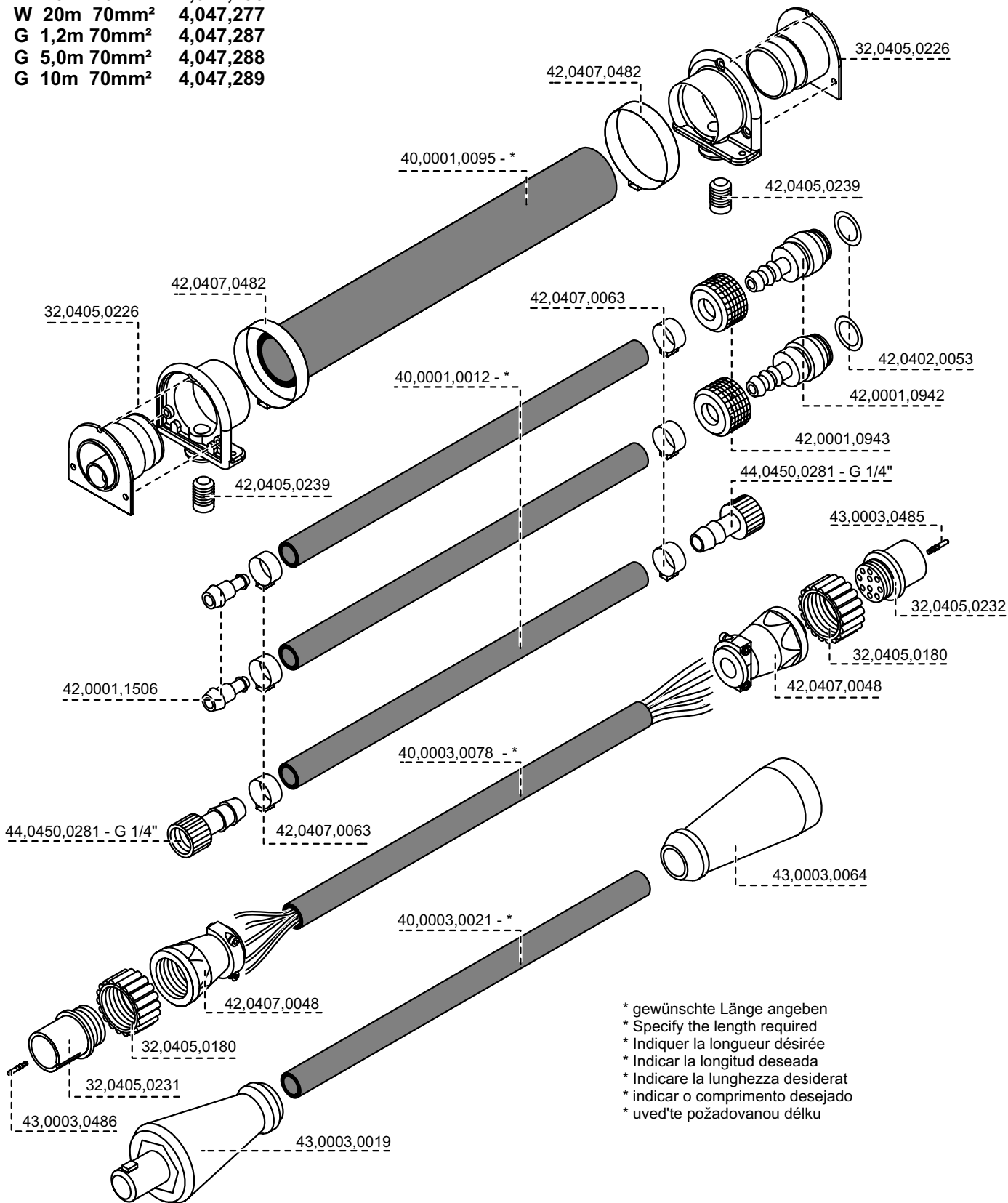

\* gewünschte Länge angeben  
 \* Specify the length required  
 \* Indiquer la longueur désirée  
 \* Indicar la longitud deseada  
 \* Indicare la lunghezza desiderata  
 \* indicar o comprimento desejado  
 \* uved'te požadovanou délku



**Connection hose pack**

Ersatzteilliste / Spare parts list / Listes de pièces de rechange / Lista de repuestos / Lista de peças sobresselentes / Lista dei Ricambi

G 50mm<sup>2</sup> 4m 4,047,411  
 G 70mm<sup>2</sup> 8m 4,047,412

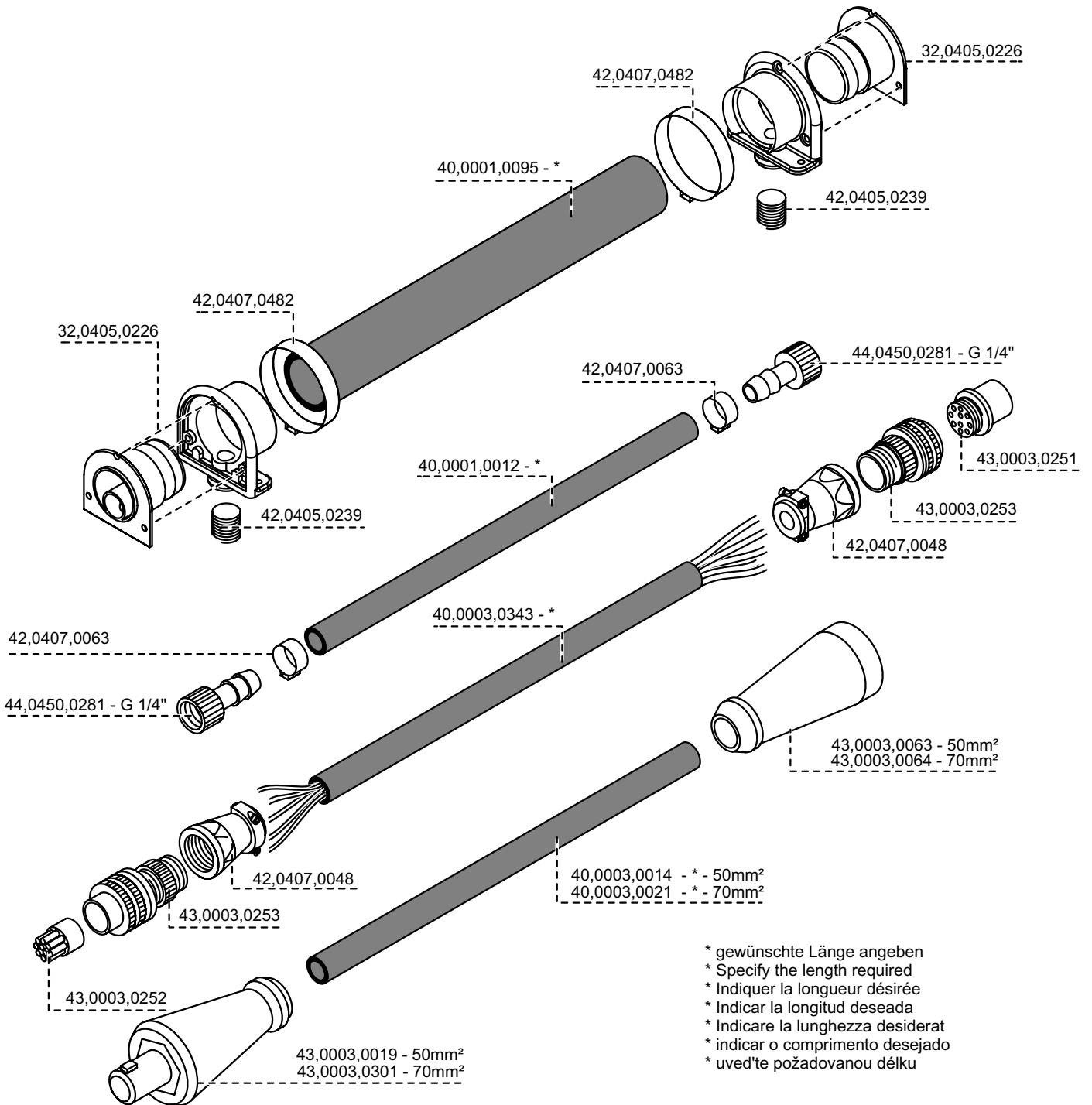

Connection hose pack

Ersatzteilliste / Spare parts list / Listes de pièces de rechange / Lista de repuestos / Lista de peças sobresselentes / Lista dei Ricambi

G 50mm<sup>2</sup> 1,2m 4,047,408  
 G 50mm<sup>2</sup> 5m 4,047,409  
 G 50mm<sup>2</sup> 10m 4,047,410

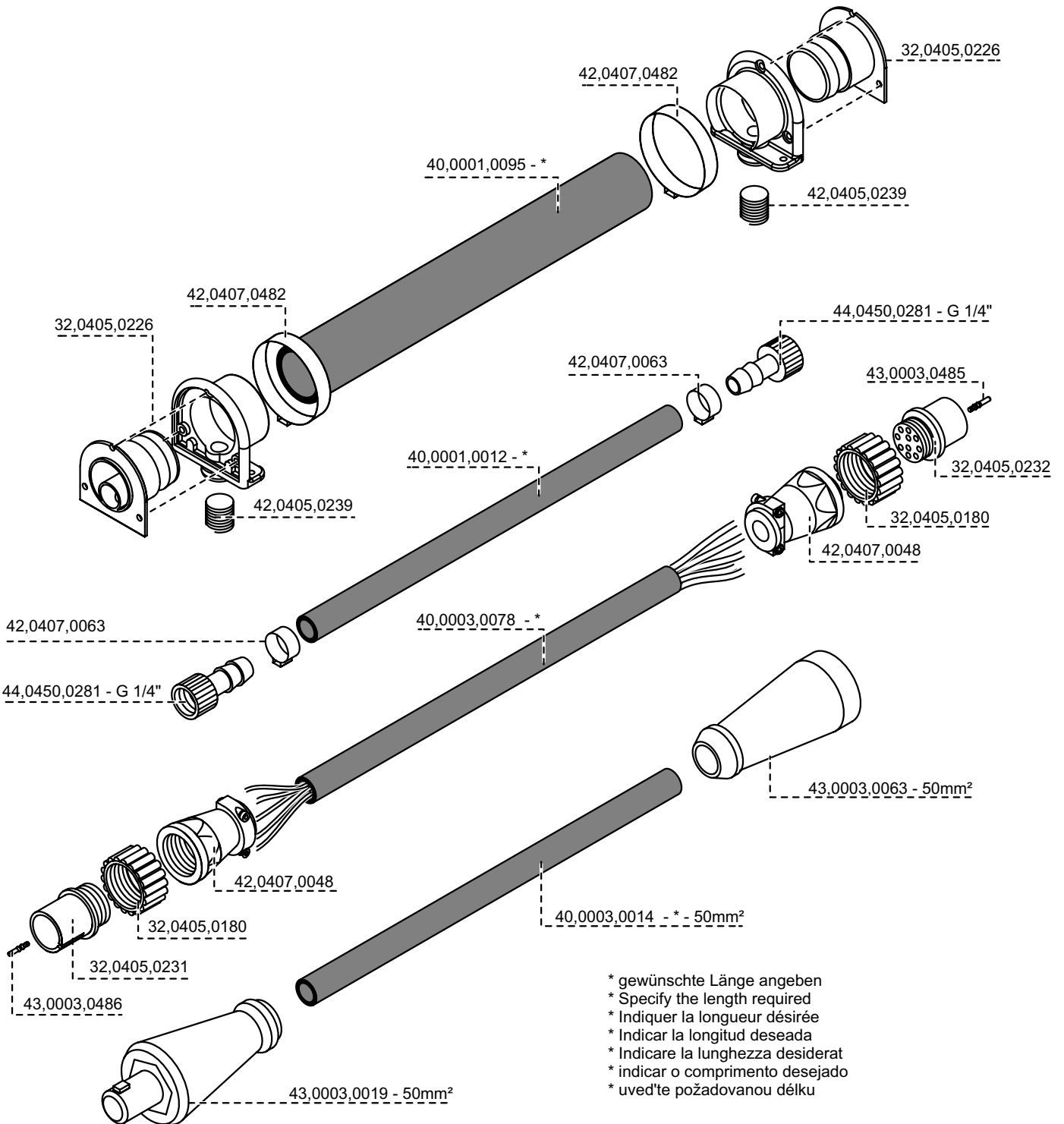

\* gewünschte Länge angeben  
 \* Specify the length required  
 \* Indiquer la longueur désirée  
 \* Indicar la longitud deseada  
 \* Indicare la lunghezza desiderata  
 \* indicar o comprimento desejado  
 \* uved'te požadovanou délku



**Connection hose pack**

Ersatzteilliste / Spare parts list / Listes de pièces de rechange / Lista de repuestos / Lista de peças sobresselentes / Lista dei Ricambi

**W 1,2m 70mm<sup>2</sup> LHSB 4,047,438**  
**W 4m 95mm<sup>2</sup> LHSB 4,047,427**  
**W 8m 95mm<sup>2</sup> LHSB 4,047,428**  
**W 15m 95mm<sup>2</sup> LHSB 4,047,448**

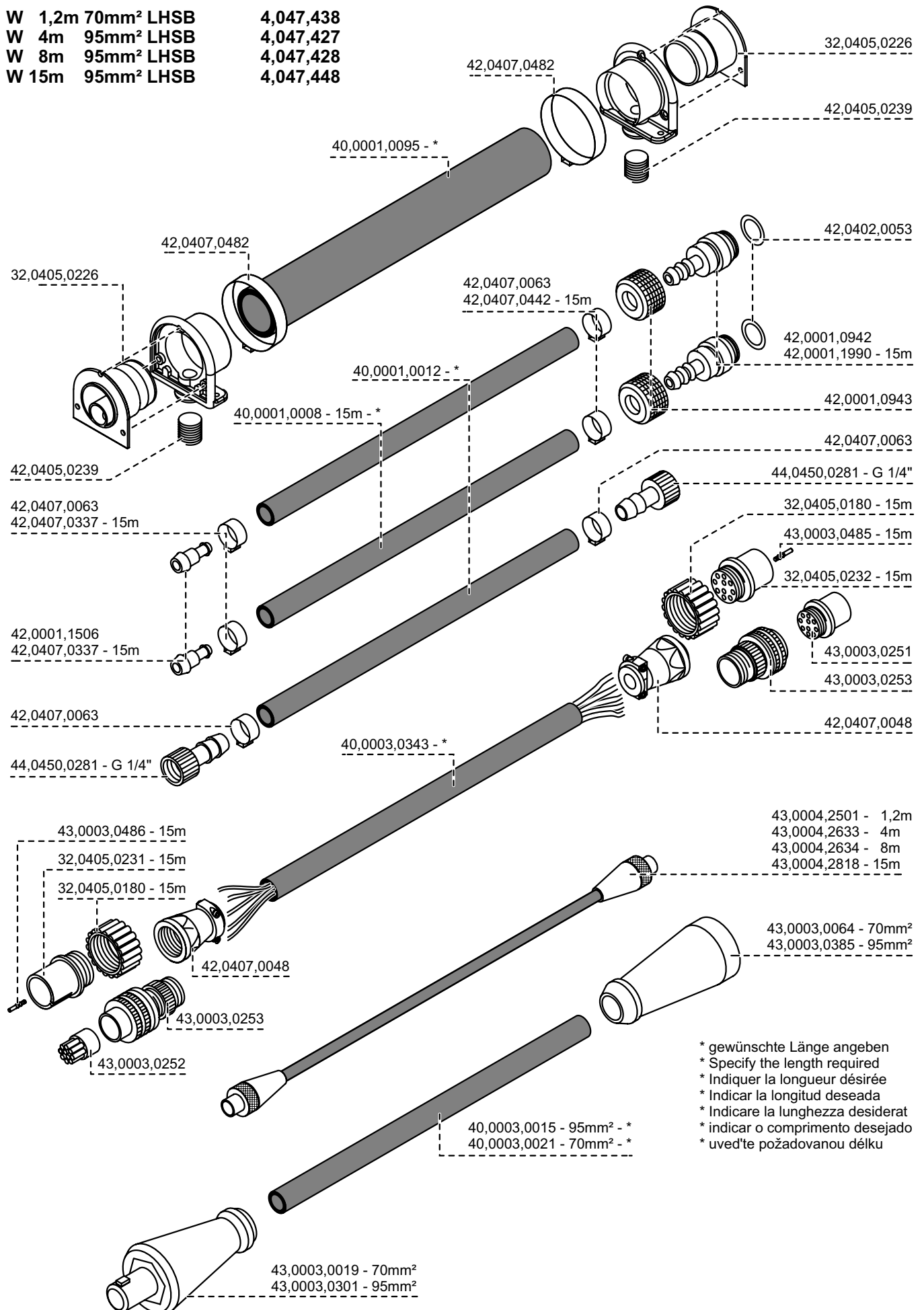

\* gewünschte Länge angeben  
 \* Specify the length required  
 \* Indiquer la longueur désirée  
 \* Indicar la longitud deseada  
 \* Indicare la lunghezza desiderata  
 \* indicar o comprimento desejado  
 \* uved'te požadovanou délku



**Connection hose pack**

Ersatzteilliste / Spare parts list / Listes de pièces de rechange / Lista de repuestos / Lista de peças sobresselentes / Lista dei Ricambi

# Fronius Worldwide - [www.fronius.com/addresses](http://www.fronius.com/addresses)

**A** **FRONIUS International GmbH**  
4600 Wels, Buxbaumstraße 2  
Tel: +43 (0)7242 241-0  
Fax: +43 (0)7242 241-3940  
E-Mail: [sales@fronius.com](mailto:sales@fronius.com)  
<http://www.fronius.com>

4600 Wels, Buxbaumstraße 2  
Tel: +43 (0)7242 241-0  
Fax: +43 (0)7242 241-3940  
Service: DW 3070, 3400  
Ersatzteile: DW 3390  
E-Mail: [sales.austria@fronius.com](mailto:sales.austria@fronius.com)

6020 Innsbruck, Amraserstraße 56  
Tel: +43 (0)512 343275-0  
Fax: +43 (0)512 343275-725

5020 Salzburg, Lieferinger Hauptstr. 128  
Tel: +43 (0)662 430763  
Fax: +43 (0)662 430763-16

1100 Wien, Daumegasse 7,  
Team Süd / Ost  
Tel: +43 (0)1/600 41 02-7410  
Fax: +43 (0)1/600 41 02-7490  
Team Nord / West  
Tel: +43 (0)1/600 41 02-7050  
Fax: +43 (0)1/600 41 02-7160

**Haberkorn Ulmer GmbH**  
6961 Wolfurt, Hohe Brücke  
Tel: +43 (0)5574 695-0  
Fax: +43 (0)5574 2139  
<http://www.haberkorn.com>

**Wilhelm Zultner & Co.**  
8042 Graz, Schmiedstraße 7  
Tel: +43 (0)316 6095-0  
Fax: +43 (0)316 6095-80  
Service: DW 325, Ersatzteile: DW 335  
E-Mail: [vkm@zultner.at](mailto:vkm@zultner.at)

**Wilhelm Zultner & Co.**  
9020 Klagenfurt, Fallegasse 3  
Tel: +43 (0)463 382121-0  
Fax: +43 (0)463 382121-40  
Service: DW 430, Ersatzteile: DW 431  
E-Mail: [vkk@zultner.at](mailto:vkk@zultner.at)

**BR** **FRONIUS do Brasil LTDA**  
Av. Senador Vergueiro, 3260  
Vila Tereza, Sao Bernado do Campo - SP  
CEP 09600-000, SÃO PAULO  
Tel: +55 (0)11 4368-3355  
Fax: +55 (0)11 4177-3660  
E-Mail: [sales.brazil@fronius.com](mailto:sales.brazil@fronius.com)

**CH** **FRONIUS Schweiz AG**  
8153 Rümlang, Oberglatterstraße 11  
Tel: +41 (0)1817 9944  
Fax: +41 (0)1817 9955  
E-Mail: [sales.switzerland@fronius.com](mailto:sales.switzerland@fronius.com)

**CZ** **FRONIUS Česká republika s.r.o.**  
381 01 ČESKÝ KRUMLOV, Tovární 170  
Tel: +420 380 705 111  
Fax: +420 380 711 284  
E-Mail: [sales.c.krumlov@fronius.com](mailto:sales.c.krumlov@fronius.com)

100 00 PRAHA 10, V Olšínách 1022/42  
Tel.: +420 272 111 011, 272 742 369  
Fax: +420 272 738 145  
E-Mail: [sales.praha@fronius.com](mailto:sales.praha@fronius.com)

315 00 PLZEŇ-Božkov, Letkovská 38  
Tel: +420 377 183 411  
Fax: +420 377 183 419  
E-Mail: [sales.plzen@fronius.com](mailto:sales.plzen@fronius.com)

500 04 HRADEC KRÁLOVÉ,  
Pražská 293/12  
Tel.: +420 495 070 011  
Fax: +420 495 070 019  
E-Mail: [sales.h.kralove@fronius.com](mailto:sales.h.kralove@fronius.com)

**CZ** 586 01 JIHLAVA, Brněnská 65  
Tel: +420 567 584 911  
Fax: +420 567 305 978  
E-Mail: [sales.jihlava@fronius.com](mailto:sales.jihlava@fronius.com)

709 00 OSTRAVA - Mariánské Hory,  
Kollárova 3  
Tel: +420 595 693 811  
Fax: +420 596 617 223  
E-Mail: [sales.ostrava@fronius.com](mailto:sales.ostrava@fronius.com)

760 01 ZLÍN  
ul. Malá (za Čerp. st. ARAL)  
Tel: +420 577 311 011  
Fax: +420 577 311 019  
E-Mail: [sales.zlin@fronius.com](mailto:sales.zlin@fronius.com)

**D** **FRONIUS Deutschland GmbH**  
36119 Neuhaus-Dorfborn bei Fulda,  
Am Stockgraben 3  
Tel: +49 (0)6655 91694-0  
Fax: +49 (0)6655 91694-10  
E-Mail: [sales.germany@fronius.com](mailto:sales.germany@fronius.com)

90530 Wendelstein,  
Wilhelm-Maisel-Straße 32  
Tel: +49 (0)9129 2855-0  
Fax: +49 (0)9129 2855-32

51149 Köln, Gremberghoven,  
Welsersstraße 10 b  
Tel: +49 (0)2203 97701-0  
Fax: +49 (0)2203 97701-10

57052 Siegen, Alcher Straße 51  
Tel: +49 (0)271 37515-0  
Fax: +49 (0)271 37515-15

38640 Goslar, Im Schleeke 108  
Tel: +49 (0)5321 3413-0  
Fax: +49 (0)5321 3413-31

10365 Berlin, Josef-Orlopp-Str. 92-106  
Tel: +49 (0)30 557745-0  
Fax: +49 (0)30 557745-51

21493 Talkau, Dorfstraße 4  
Tel: +49 (0)4156 8120-0  
Fax: +49 (0)4156 8120-20

70771 Leinfelden-Echterdingen  
(Stuttgart),  
Kolumbus-Straße 47  
Tel: +49 (0)711 782852-0  
Fax: +49 (0)711 782852-10

04328 Leipzig, Riesaer Straße 72-74  
Tel: +49 (0)341 27117-0  
Fax: +49 (0)341 27117-10

01723 Kesselsdorf (Dresden),  
Zum alten Dessauer 13  
Tel: +49 (0)35204 7899-0  
Fax: +49 (0)35204 7899-10

67753 Hefersweiler, Sonnenstraße 2  
Tel: +49 (0)6363 993070  
Fax: +49 (0)6363 993072

18059 Rostock, Erich Schlesinger Str. 50  
Tel: +49 (0)381 4445802  
Fax: +49 (0)381 4445803

81379 München, Gmunder Straße 37a  
Tel: +49 (0)89 748476-0  
Fax: +49 (0)89 748476-10

83308 Trostberg, Pechleraustraße 7  
Tel: +49 (0)8621 8065-0  
Fax: +49 (0)8621 8065-10

94491 Hengersberg, Donaustraße 31  
Tel: +49 (0)9901 2008-0  
Fax: +49 (0)9901 2008-10

**F** **FRONIUS France SARL**  
60306 SENLIS CEDEX,  
13 avenue Félix Louat - B.P.195  
Tél: +33 (0)3 44 63 80 00  
Fax: +33 (0)3 44 63 80 01  
E-Mail: [sales.france@fronius.com](mailto:sales.france@fronius.com)

**N** **FRONIUS Norge AS**  
3056 Solbergelva, P.O. BOX 32  
Tel: +47 (0)32 232080,  
Fax: +47 (0)32 232081  
E-Mail: [sales.norway@fronius.com](mailto:sales.norway@fronius.com)

**SK** **FRONIUS Slovensko s.r.o.**  
917 01 Trnava, Nitrianská 5  
Tel: +421 (0)33 590 7511  
Fax: +421 (0)33 590 7599  
E-Mail: [sales.slovakia@fronius.com](mailto:sales.slovakia@fronius.com)

974 03 Banská Bystrica,  
Zvolenská cesta 14  
Tel: +421 (0)48 472 0611  
Fax: +421 (0)48 472 0699  
E-Mail: [sales.b.bystrica@fronius.com](mailto:sales.b.bystrica@fronius.com)

**UA** **FRONIUS Ukraine GmbH**  
07455 Ukraine, Kiwskaya OBL...,  
S. Knjashitschi, Browarskogo R-NA  
Tel: +38 044 94-62768  
+38 044 94-54170  
Fax: +38 044 94-62767  
E-Mail: [sales.ukraine@fronius.com](mailto:sales.ukraine@fronius.com)

**USA** **FRONIUS USA LLC**  
10421 Citation Drive,  
Brighton, Michigan 48116  
Tel: +1(0) 810 220-4414  
Fax: +1(0) 810 220-4424  
E-Mail: [sales.usa@fronius.com](mailto:sales.usa@fronius.com)