



Operating Manual

Transmatic Lynx 2, 4HD, 4EHD



**Please ensure that this
Instruction Manual
is made available
to the user
of the equipment.**

MUREX 



DECLARATION OF CONFORMITY

Murex Welding Products Ltd.,

Declare hereby that:

Murex Transmatic Lynx 2, 4HD & 4EHD Wire Feed Units

Part Nos. 1415973, 1415974 & 1415975

- are manufactured in accordance with the Council Directive 73/23/EEC (1973-02-19) and 89/336/EEC (1989-05-03) amended by Council Directive 93/68/EEC relating to electrical equipment designed for use within certain voltage limits
- conform with the protection requirements of Council Directive 89/336/EEC, amended by Council Directives 91/263/EEC, 92/31/EEC and 93/68/EEC relating to electromagnetic compatibility.
- are manufactured in accordance with EN60974-1 Safety Requirements for Arc Welding Equipment
- are manufactured in accordance with EN50199 Electromagnetic Compatibility for Arc Welding Equipment

On behalf of Murex Welding Products Ltd
Hertford Road
Waltham Cross
Herts EN8 7RP
England

A handwritten signature in black ink, appearing to read "P G Dodd".

P G Dodd
Managing Director

1st January 2002



Contents

	Page
Warnings	3
Safety	4
Introduction	5
Controls	6
Installation	7
Optional Extras	10
Specification	12
Circuit Diagram	13
Maintenance	14
Parts List	15



WARNING



This welding equipment has been designed, manufactured and tested to the highest standards to ensure long and trouble free life. However, regular maintenance is an essential part of keeping the machine operating in a reliable and safe manner and your attention is drawn to any maintenance instructions that are contained in this manual.

In general, all welding equipment should be thoroughly inspected, tested and serviced at least annually. More frequent checking will be required when the equipment is heavily used.

Wear and tear, particularly in electro-mechanical and moving components, are gradual processes. Caught in time, repair costs are small and the benefits in performance reliability and safety are significant. Left alone, they can put the equipment, and you, at risk.

Have this equipment regularly inspected and maintained by an approved service centre.



WARNING



ARC WELDING AND CUTTING CAN BE INJURIOUS TO YOURSELF AND OTHERS. TAKE PRECAUTIONS WHEN WELDING. ASK FOR YOUR EMPLOYER'S SAFETY PRACTICES WHICH SHOULD BE BASED ON MANUFACTURERS' HAZARD DATA.

ELECTRIC SHOCK - Can Kill

- Install and earth the welding unit in accordance with applicable standards.
- Do not touch live electrical parts or electrodes with bare skin, wet gloves, or wet clothing.
- Insulate yourself from earth and work.
- Ensure your working position is secure.

FUMES AND GASES - Can be Dangerous to Health

- Keep your head out of the fumes.
- Use ventilation, extraction at the arc, or both, to keep fumes and gases from your breathing zone and the general area.

ARC RAYS - Can Injure Eyes and Burn Skin

- Protect your eyes and body. Use the correct welding screen and filter lens and wear protective clothing.
- Protect bystanders with suitable screens or curtains.

NOISE- Excessive noise can damage hearing

- Protect your ears. Use ear defenders or other hearing protection.
- Warn bystanders of the risks.

**READ AND UNDERSTAND THE INSTRUCTION MANUAL
BEFORE INSTALLING OR OPERATING AND SEE WMA PUBLICATION 237
'The arc welder at work' AVAILABLE FROM THE MANUFACTURER.**

PROTECT YOURSELF AND OTHERS

SAFETY

In any arc welding or gouging operation, it is the responsibility of the user to observe certain safety rules to ensure his personal safety and to protect those working near him.

Read all safety articles relevant to arc welding published by the WMA. Pay particular attention to any **CAUTION** or **WARNING** Notes included in this manual. **CAUTION** indicates possible equipment damage. **WARNING** indicates possible hazard to life.

⚠ **WARNING** ⚠

The ON/OFF switch on this equipment does not isolate the unit from the mains electrical supply. **AC POWER IS PRESENT ON THE ON/OFF SWITCH TERMINALS.**

The On/Off lamp is an indication that the supply is switched on and does not imply that the unit is isolated from the supply. **BEFORE REMOVING THE COVERS FOR MAINTENANCE, ISOLATE THE UNIT FROM THE MAINS ELECTRICAL SUPPLY.**

1. Electrical

⚠ Treat electricity with respect. Even the open circuit voltage of this equipment can be dangerous. Adjustments to the torch or replacement of torch parts should be undertaken with the mains supply isolated from the unit.

If damaged torch cables or torch components are found, the unit must be disconnected from the mains and defective parts must be replaced using only Murex spare parts.

⚠ Do not work on live circuits or cables. Disconnect the main power supply before checking the machine or performing any maintenance operation.

⚠ Be sure the case of the welding machine is properly connected to a good electrical earth.

⚠ Have the wiring for the welding machine installed by a qualified electrician. All connections must be made according to specifications in force and to general safety standards.

⚠ Do not stand in water or on damp floors while using an arc welder or cutter. Do not use in the rain.

⚠ Do not operate with worn or poorly connected cables. Inspect all cables frequently for insulation failure, exposed wires and loose connections.

⚠ Do not overload cables or continue to operate with overheating cables. Cables which are too small for the current carried will overheat, causing rapid deterioration of the insulation.

⚠ Pay attention that live parts of the torch do not touch any metal which is connected to the earth cable. Fix an insulated hook to hang the torch on when it is not in use.

1. Ventilation

⚠ Do not weld or cut on containers which have held combustible or flammable materials, or materials which give off flammable or toxic vapours when heated, without proper cleaning.

⚠ Locate the welding/cutting operation far enough from any vapour-type degreaser using trichlorethylene or other chlorinated hydrocarbons as solvents. The ultraviolet light from the arc can decompose these vapours into toxic gases at a considerable distance from the arc, even though the concentration of the gases is low enough to be undetectable by smell.

⚠ Be sure to provide adequate ventilation for removal and dilution of fume and gases. Fume exhaust facilities near the arc, or a ventilated helmet should be used when cutting in confined spaces or on toxic material.

2. Glare

⚠ Never look at the arc without wearing eye protection. Always use the proper protective clothing, filter glasses, and gloves. Be careful to avoid exposed skin areas. Do not use cracked or defective helmets or shields.

⚠ Never strike an arc when there is someone near who is not protected from the strong light of the arc.

⚠ Warn bystanders who are not aware of the dangers of ultra-violet light.

3. General

⚠ Take care when lifting the unit.

⚠ Ensure that cylinders are secured by chains.

⚠ Locate the unit so that there is adequate air flow to the ventilation louvres.

⚠ Always dress correctly to protect against glare, radiation and spatter.

4. Fire

⚠ Ensure that the correct type of fire extinguisher is available in the welding area.

⚠ Do not weld near flammable materials or liquids, in or near explosive atmospheres, or on pipes carrying explosive gases.

5. Vehicle Electrics

⚠ When working on motor vehicles, remove the battery and any circuitry which may be damaged by the arc.

⚠ Whilst welding be aware of the possibility of 'hidden wires' behind panels or bulkheads.

6. Moving Parts



Switch off before accessing areas which contain moving parts. Particular care should be taken when accessing the wire feed mechanism.



Fig 1 - Transmatic Lynx 2, 4HD & 4EHD

INTRODUCTION

The Transmatic Lynx 2, 4HD and 4EHD are feed units designed for use in MIG/MAG welding installations to feed hard, soft or tubular (cored) wires. Details of the wire sizes handled are given in the specification (see Technical Notes.)

A quick-fit central adaptor (Euroconnector) allows the full range of air and water-cooled torches to be fitted quickly and with minimum preparation. When using a water-cooled torch the water adaptor kit must be fitted. (See page 16.)

Wire is fed from the feeder by either two or four driven feed rolls. The feed rolls are driven by a d.c. motor using a worm-drive and spur gears.

When changing wire sizes the feed roll(s), outlet guide tube liner, inlet guide and intermediate guide may have to be changed, see Parts List.

Each feed roll has two alternative grooves and is stamped with the wire size on the outside (facing the operator) edge.

The pressure roll tension(s) can be adjusted to counteract wire slip and provision is made to change guide tubes to optimise conditions for various wire sizes.

Standard facilities include variable wire feed speed, wire inching, gas purge, torch switch latching and variable burn back timer. The Lynx 2 and 4HD models also incorporate a spot weld timer.

The Transmatic Lynx 4EHD incorporates an arc voltage control which operates with the electronically controlled Transmig 413S or 513S power sources.

The unit is fitted with a plastic hub designed to accept a standard reel of wire. A 30kg reel holder and mounting plate, wire basket or reel cover kit can be fitted. (See Optional Extras, page 16)

Overrun braking adjustment facilities are provided in the hub.

Water Adaptor Kit - (See page 16)

Required where a water-cooled torch is to be employed, this kit contains the hoses and quick fit unions which enable the water supply and torch water hoses to be coupled to the wire feed unit.

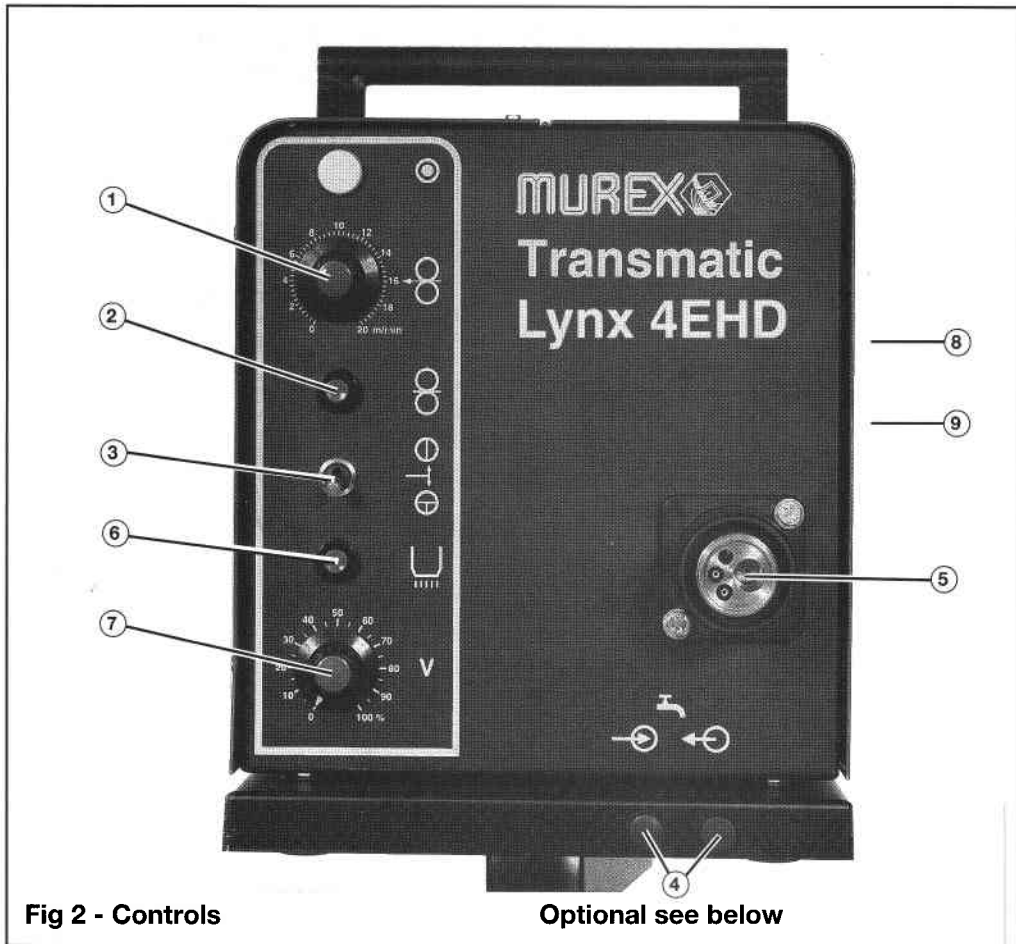

Fig 2 - Controls

Optional see below

CONTROLS

1. Wire Feed Speed Control

Provides continuously variable wire feed speed control. The wire speed is directly proportional to welding current so that increasing the speed increases current and vice-versa.

2. Wire Inch Button

Operates the wire feed motor but not the other welding services. It is used to 'inch' the wire through the equipment during setting up and adjustment procedures.

3. Latching Switch

This switch provides latching facilities as follows:

Unlatched (2 stroke) down

Press - Continuous welding whilst torch switch held pressed.

Release - Welding stops.

Latched (4 stroke) up

Press - Gas Purge

Release - Continuous welding

Press - Welding stops, gas continues giving post weld gas coverage.

Release - gas stops.

4. Water Adaptor Fitting Holes

Water out torch.

Water return from torch. When a water-cooled torch is used the water

connections are mounted in the holes provided. These connections are contained in the water adaptor kit. See Optional Extras.

5. Central Adaptor

Allows for quick fitting torches including gas connection, wire outlet and torch switch connections.

6. Gas Purge Button

When operated, opens the gas valve in the unit, allowing the gas to flow through to the welding torch. It is used when initially adjusting the gas flow and when purging the gas lines of air.

7. 2 & 4HD - Spot Weld ON/OFF and Timer Control

Switches the spot weld timer on (unlatched/2 stroke mode only, see 3.) and allows the operator to select a suitable weld time to provide sufficient

penetration of the weld spot relative to the material being welded.

7. 4EHD - Voltage Control

Enables the setting of the power source/arc voltage when the feeder is being used with either a Transmig 403 or 503 power source.

8. Acceleration Switch (not shown, positioned inside wire feed compartment)

This 3 position switch varies the time it takes the welding wire to accelerate to the set wire feed speed after the torch switch is activated. This switch would usually be used in the "Normal" position. However for aluminium welding or in the event of arc striking problems, the "Medium" or "Slow" position can be used.

9. Burn back Time Control (not shown, positioned inside wire feed compartment)

Provides continuously variable burn back time control. To ensure the wire is not left stuck into the weld metal when welding is stopped, burn back time is provided delaying the opening of the contactor and gas turn off after the wire feed is stopped. Generally higher values of burn-back time are required at higher currents/wire feed speed settings.

INSTALLATION

INITIAL SETTING UP

1. Feed Rolls

Note: When changing wire sizes the inlet guide, intermediate guide, outlet guide tube liner and feed rolls may need changing as given below.

Before connecting the electrical and gas supplies, ensure that the equipment is set up for the type and size of wire to be used as follows:

- (a) Power Source switched off.
- (b) When changing wire sizes it may be necessary to change the feed roll(s), outlet guide tube liner, inlet guide and intermediate guide.

The size of feed roll is stamped on the visible surface of the roll when fitted - See 'Feed Roll changing'.

2. Interconnections

Lay out the torch leads keeping the leads as straight as possible. Check that the power source is switched off.

CAUTION: Do not extend the interconnections beyond 20m, if in doubt call your nearest Murex distributor for advice.

3. Gas

Connect the shielding gas hose between the regulator and the nipple provided on the rear panel.

4. Connect and Power Cable

Connect the control and power cables between the fittings on the rear panel and the socket on the power source.

5. Work Return Lead

Connect the work return lead to a clean area on the work piece.

WELDING WIRE

Fit the reel of welding wire:

1. Remove the hand nut from the hub.
2. Place the reel of wire on the hub so that the wire will be drawn off from the bottom. Ensure that the pin on the hub locates in the hole in the side of the reel.
3. Release the end of the wire from the side of the reel but do not allow the coils to loosen. Cut off the kinked portion and remove any sharp edges from the end of the wire. This must be done every time the wire is threaded

through the equipment.

4. Loosen the hub reel brake allen screw so that the reel revolves freely. Tighten the screw just enough to prevent over-run when wire feed stops. Too much pressure will cause excessive drag.

5. Lift the pressure roll arm(s).

6. Thread the wire through the inlet guide over the feed roll(s) and into the outlet guide, for approximately 50mm (2in).

Lower the pressure roll arm(s) so that the welding wire is clamped into position in the groove.

7. Switch on the power source to obtain the 42V supply. Check the pilot light is illuminated.

8. Push the inching button - See Fig. 2. and check that the wire is driven smoothly through the outlet guide.

9. Check that the wire feed is smooth and positive. If the wire slips in the feed rolls, tighten the pressure adjuster(s) just enough to obtain positive wire feed drive.

Do not overtighten.

10. Cut off the wire to protrude 10mm from the torch connector.

TORCH

1. Check that the torch leads are laid out straight and connect the torch to the torch adaptor.

2. Remove the nozzle and contact tip from the torch.

Using the inching button, feed the wire through the torch.

Thread a contact tip over the wire and screw it into the torch.

Tighten the contact tip with the key provided.

3. Fit the appropriate nozzle.

4. Press the torch switch and check that wire flows smoothly from the torch.

REPLACEMENTS AND ADJUSTMENTS

1. Outlet Guide Tube Liner Removal

(a) Release the pressure roll(s).

(b) Loosen the retaining cap nut on the brass outlet connection tube and push out the guide tube liner using a suitable soft tool (e.g. dowel) then withdraw it from the torch adaptor using a pair of long nose pliers.

If the guide tube liner does not move freely, it may be necessary to drive it

out using a hard wooden dowel or old guide tube.

Note: Do not use a screwdriver or metal tool to push out the tube. Use of such a tool may score the end of the guide tube and impair wire feeding.

2. Feed Roll Changing

Remove the feedroll retaining screw(s). it will be necessary to give the screwdriver a sharp twist to avoid turning the motor.

Lift the pressure arm(s) and pull off the feedroll(s), note the wire size which is stamped on the face of the roll(s).

The required size must face outwards when the roll is fitted.

Fit the feedroll(s) and lower the pressure arm(s). Refit the retaining screw(s) giving a sharp twist with the screwdriver to tighten.

3. Inlet Guide Replacement

Slacken retaining screw and pull inlet guide out from the rear.

4. Intermediate Guide Replacement

Release pressure arm. Slacken intermediate guide retaining screw. Remove rear feed roll. Slide out intermediate guide from the rear.

5. Overrun Adjustment

Tighten or unscrew the allen screw in the centre of the wire reel hub until sufficient hub friction is achieved to prevent overrun.

Note: Do not overtighten or the wire will slip in the feed rolls.

6. Feed Roll Pressure

Correct feed roll pressure will provide smooth, uninterrupted feeding of the wire. Inspection of the wire should reveal only slight marks from the feed rolls and no deformation of the wire. Use of the correct pressure is especially important when feeding aluminium wires. The pressure should be just enough to provide positive wire drive without slipping.

7. Burn Off Adjustment

If burn off requires adjustment, it can be set using the control in the wire feed compartment, see Controls.



WARNING

Switch off before accessing feed rollers

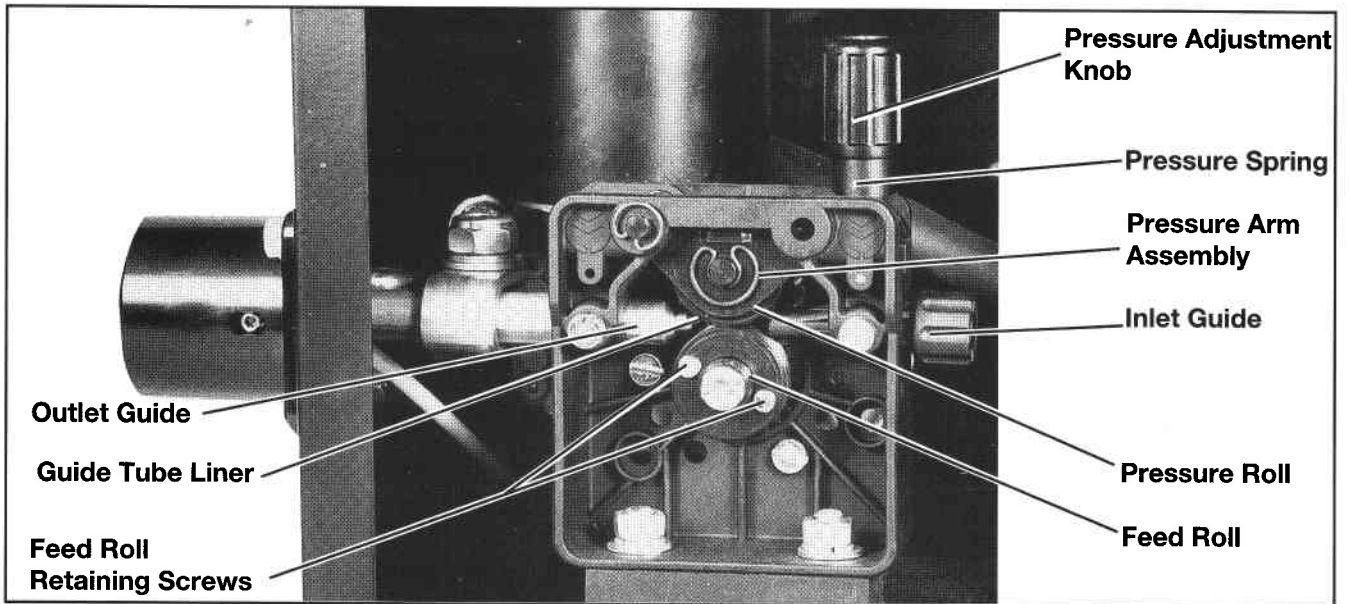

Fig 3 - Lynx 2 Feed Roll Assembly

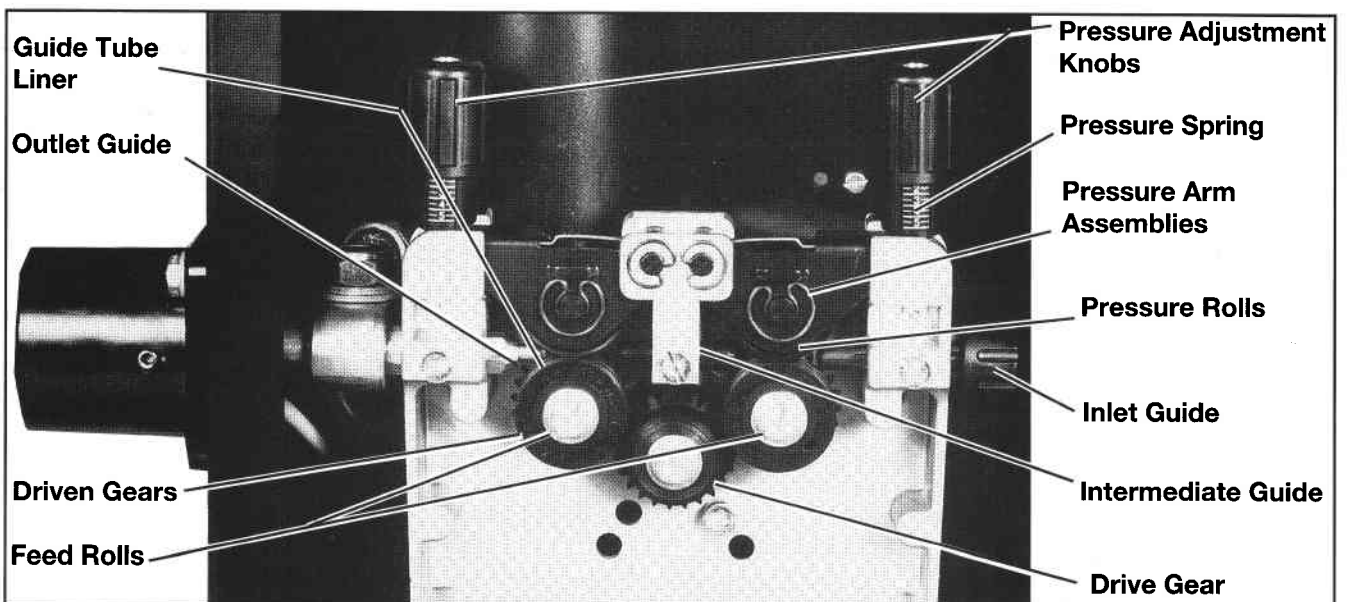
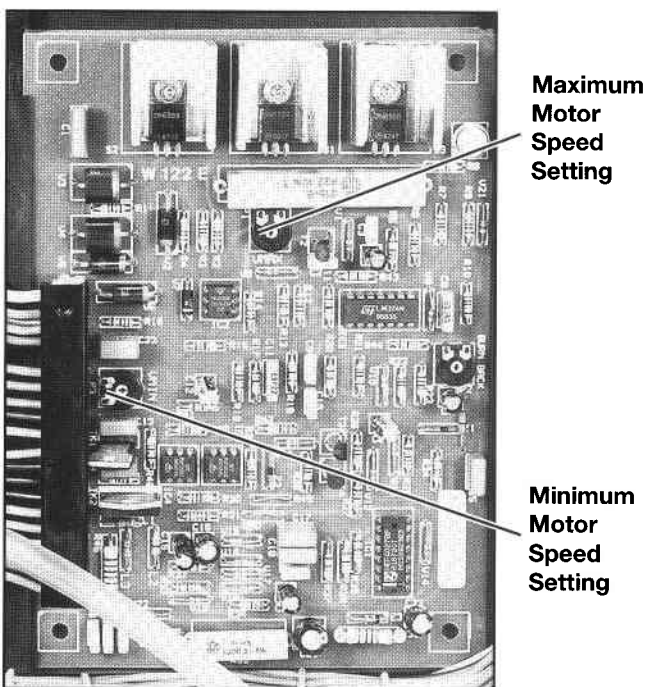
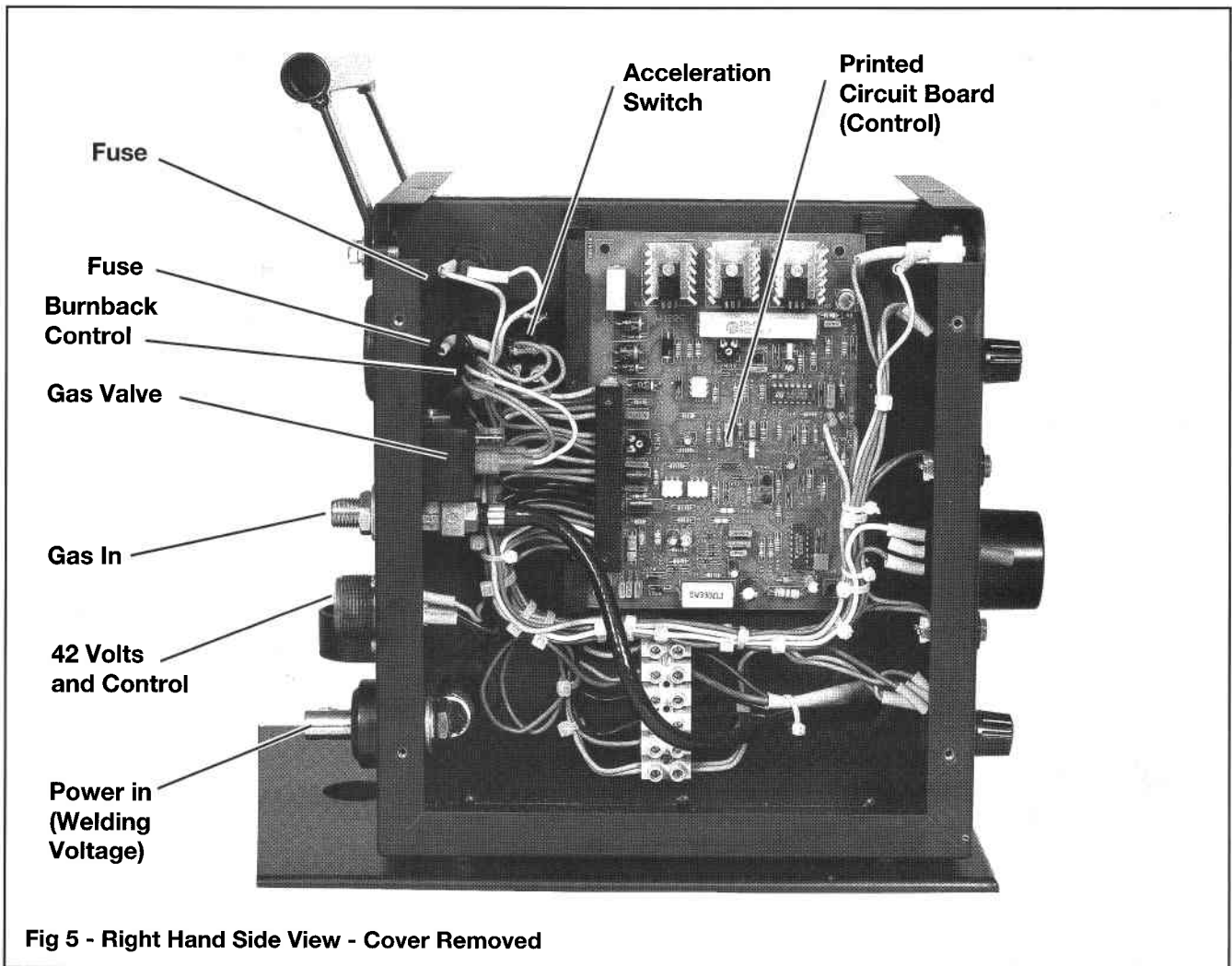

Fig 4 - Lynx 4 HD & 4 EHD Feed Roll Assembly



Calibration Procedure

The Transmatic Lynx 2, 4HD & 4EHD feeders are each calibrated to offer a wire speed range of 1 - 20m/min, i.e., 10 - 210 r.p.m. at the feed rolls.

Preset potentiometers, labelled Vmin and Vmax located on the printed circuit control board permit adjustment/calibration of the maximum and minimum feed speeds.

When checking or calibrating the wire feed unit ensure an accurate tachometer is used to confirm speeds.

FAULT	POSSIBLE CAUSE AND REMEDY
1. Weld deposit 'Stringy' and incomplete	1a. Torch moved workpiece too quickly 1b. Gas mixture incorrect
2. Weld deposit too thick	2a. Torch moved over workpiece too slowly 2b. Welding voltage too low
3. Arc unstable, excessive spatter and weld	3a. Torch held too far from the workpiece 3b. Rust, grease or paint on workpiece 3c. Insufficient shielding gas, check gas contents gauge, regulator setting and operation of gas valve
4. Wire repeatedly burns back	4a. Torch held too close to the workpiece 4b. Intermittent break in the welding circuit caused by: (1) Contact tip loose - tighten (2) Contact tip damages - replace (3) Welding wire or liner corroded - replace wire or liner 4c. Wire feed slipping caused by: (1) Restriction in Liner (such as kinks) or contact tip - check and replace if necessary (2) Worn feed rolls - replace (3) Outlet guide or pressure roll adjustment incorrect
5. Burning holes in the workpiece	5a. Torch moved too slowly or erratically 5b. Welding volts too high 5c. Wire feed speed too high
6. Lack of penetration	6a. Torch moved too fast 6b. Welding volts too low 6c. Wire feed too low

OPTIONAL EXTRAS
(See also Parts List)

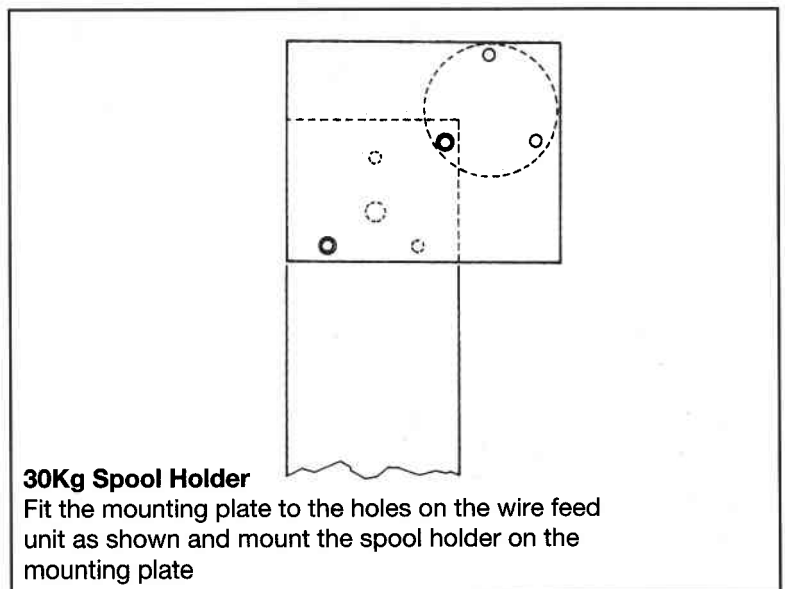
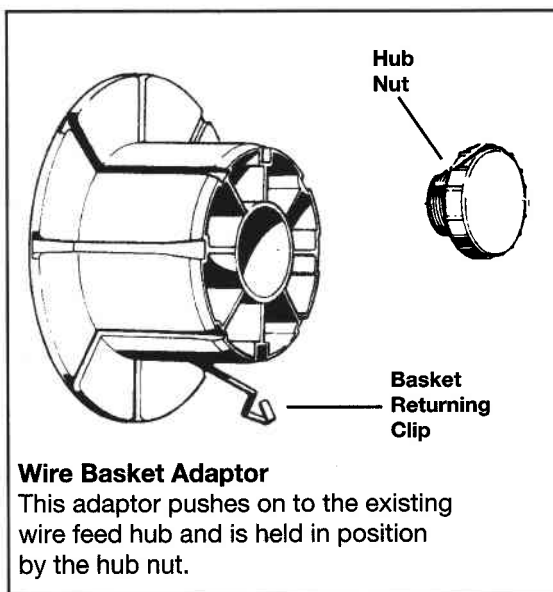

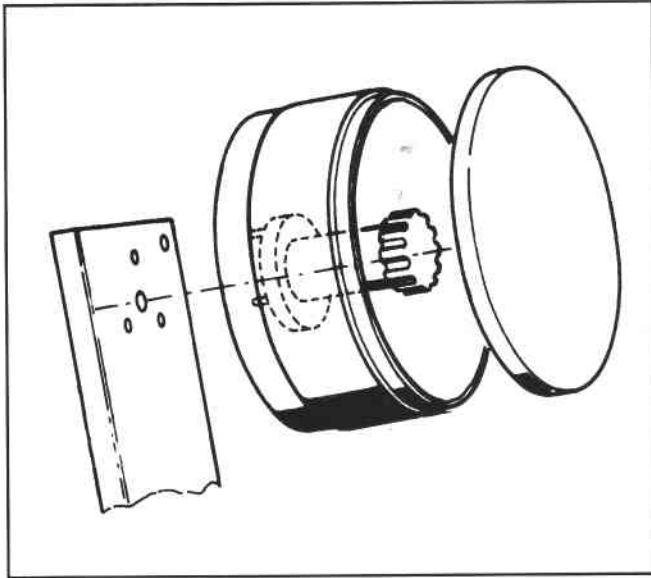

Reel Cover Kit Fitting

1. Remove reel hub, 3 nuts and washers.
2. Position back cover over mounting holes ensuring the wire outlet slot is aligned with wire feeder near inlet hole.
3. Re-fit reel hub so that retaining screws pass through back cover before attaching the metal reel stand.
4. Install wire reel, load wire ensuring kit feeds from the bottom of the reel.
5. Snap on front cover.

Water Adaptor Kit

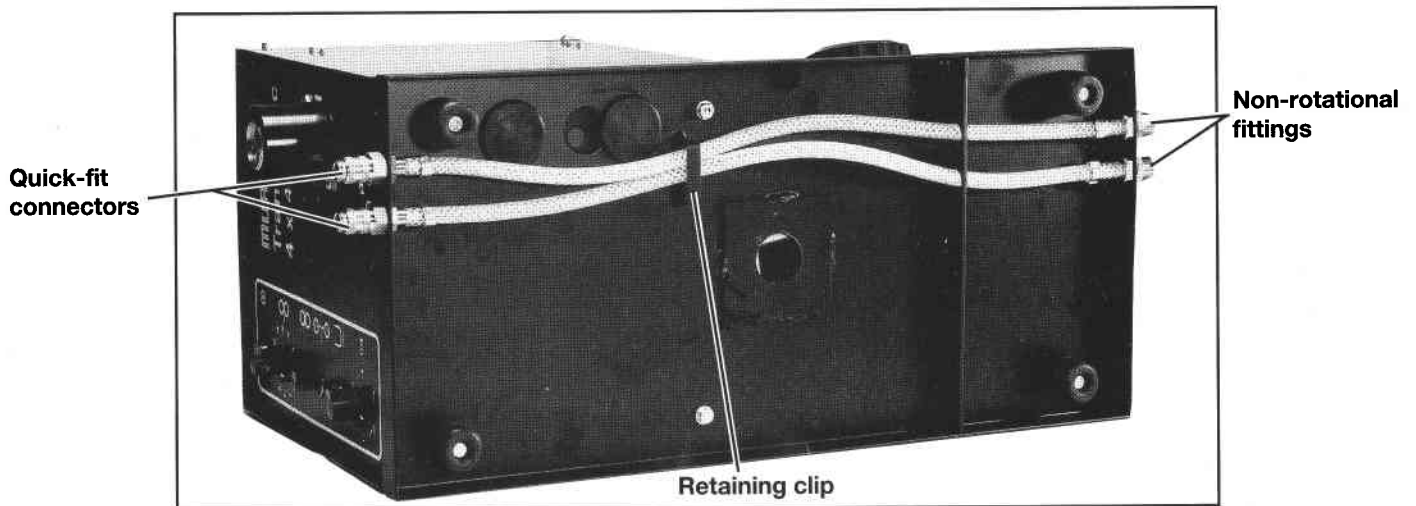

1. Fit the 'water-in' and 'water-out' hoses to the rear panel using non-rotational fittings provided.
2. Pass the hose ends under the retaining clip provided and trim off the hose ends level with the front panel.
3. Mount the quick-fit connectors in the holes in the front panel.
4. Slide a crimp over each each hose end and, ensuring that the 'water-in' on the rear panel coincides with 'water-out' on the front panel and vice-versa, push the hose ends on the quick fit connectors.
5. Using a pair of pliers, crimp the hose ends firmly.

Technical Notes

SPECIFICATION

	Transmatic Lynx 2	Transmatic Lynx 4HD	Transmatic Lynx 4EHD
Drive System	2 Roll Geared	4 Roll	4 Roll Geared
Speed Range	1 - 20 m/min	1 - 20 m/min	1 - 20 m/min
Supply Voltage	42 Vac	42 Vac	42 Vac
Wire Size:			
Hard	0.8 - 1.6mm	0.8 - 2.4mm	0.8 - 3.2mm
Soft	1.0 - 1.6mm	1.0 - 2.4mm	1.0 - 3.2mm
Cored	1.2 - 1.6mm	1.2 - 2.4mm	1.2 - 3.2mm
Dimensions:			
Height	315mm	315mm	315mm
Width	265mm	265mm	265mm
Length	600mm	600mm	600mm
Weight (approx)	15.5kg	15.5kg	15.5kg

Due to variations which can occur in manufacturing products, claimed performances, voltages, ratings, all capacities, measurements, dimensions, and weights quoted are approximate only. Achievable capacities and ratings in use and operation will depend upon correct installation, use, application, maintenance and service.

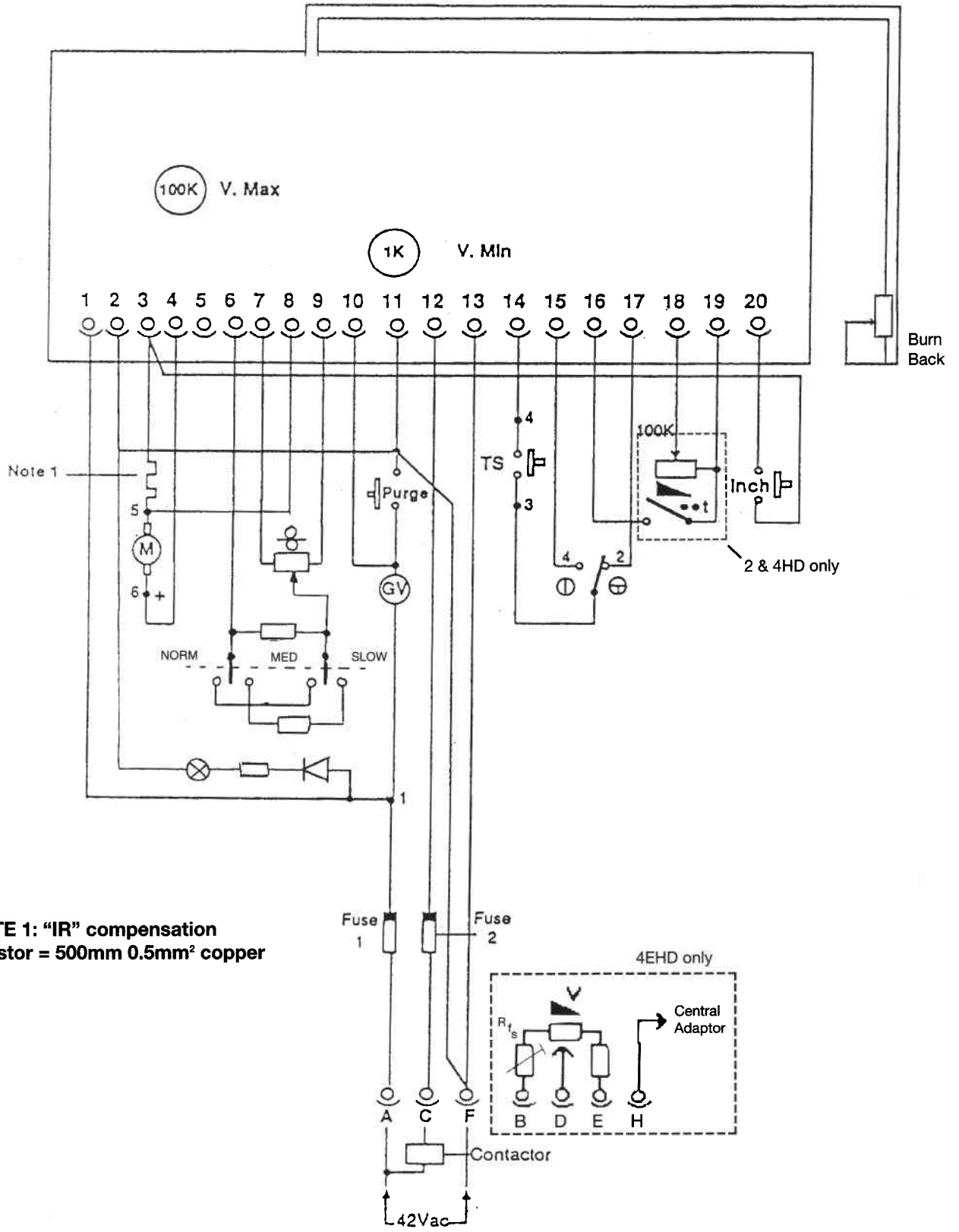

NOTE 1: "IR" compensation resistor = 500mm 0.5mm² copper

MAINTENANCE

Switch off the power source before commencing.

Before Fitting a New Spool of Wire

1. Blow through the torch liner with dry compressed air of shielding gas.
2. Remove any dirt or deposits of metal from the feed and pressure rolls.

Monthly

1. Remove the cover (retain the fixing screws).
2. Using a soft brush, remove any dust or dirt from the interior of the unit. If compressed air is used to clean the unit the pressure must not exceed 2kg/cm² (30lb/in²), and the air must be dry.

MOTOR BRUSH REMOVAL AND REPLACEMENT

The motor brushes should be periodically inspected for signs of excessive wear or damage. Brushes should be replaced when they have worn to a length of 4-5mm.

Inspection

1. Remove the motor cover screws and slide the cover upwards off the armature.
2. Examine the brushes/carrier for signs of damage or excessive wear. Also inspect the commutator for signs of tracking or excessive undercut.
3. Replace the cover ensuring the slot aligns with the key in the diecasting.

Brush Replacement - See Parts List

1. Remove motor from wire feed unit.
2. Remove motor cover as above.

SUITABLE EYE AND MOUTH PROTECTION SHOULD BE WORN.

3. Check that the internal welding cable is in good electrical contact with the welding cable connector, and the terminal block on the central adaptor.

In addition to the forgoing maintenance, remove and inspect the motor brushes for signs of damage or excessive wear as described below.

3. Remove gearbox face plate.
4. Dismount the plastic brush carrier from casting by pushing back the three rubber mountings. Remove the brushes from the carrier ensuring the springs and spring clips are not lost.
5. Detach the two brushes, red and black, from the wires inside the gearbox housing.
6. Connect new brushes, red and black, ensuring the insulation sleeving is correctly installed.
7. Refit brushes into brush carrier and fit carrier back to diecasting ensuring the rubber mountings are properly engaged in the carrier. Check the springs and spring clips are properly fitted.
8. Refit motor cover and gearbox face plate.

Parts List

When ordering spare parts, please quote both the Part Number and the description. Customers should also give the type and serial number of the unit for which the parts are required.

CONSUMABLES

Transmatic Lynx 2

Note: as standard the Lynx 2 is supplied fitted for 1.0/1.2 Hard Wires.

Wire Size & Type	Inlet Guide	Feed Roll	Pressure Roll	Outlet Guide Tube Liner (128mm)	
0.6 - 0.8H	1413103	1413458	1413844 (P)	(1.5 ID)	1413880
0.8 - 1.0H	1413103	1413459	1413844 (P)	(2.0 ID)	1413881
1.0 - 1.2H	1413103	1413486	1413844 (P)	(2.0 ID)	1413881
1.2 - 1.6H	1413103	1413843	1413844 (P)	(2.0 ID)	1413881
1.0 - 1.2S	1413103	1413460	1413844 (P)	(Nylon)	1413883
1.2 - 1.6T	1413103	1413487	1413845 (K)	(2.0 ID)	1413881

Key: P = Plain K = Knurled

Transmatic Lynx 4 HD

Note: as standard the Lynx 4HD is supplied fitted for 1.0 - 1.2 Hard Wires

Wire Size & Type	Inlet Guide	Feed Rolls (Pack of 2)	Pressure Roll (2 req'd)	Intermediate Guide	Outlet Guide Tube Liner (115.5mm)	
0.6 - 0.8H	1413103	1409001	1411478	1411769	(1.5 ID)	1413885
1.0 - 1.2H	1413103	1409002	1411478	1411769	(2.0 ID)	1413886
1.2 - 1.6H	1413103	1409003	1411478	1411769	(2.0 ID)	1413886
1.2 - 1.6T	1413103	1411533	1411478	1411769	(2.0 ID)	1413886
1.6 - 2.4T	1413854	1409005	1411478	1411770	(3.0 ID)	1413888
1.2 - 1.6S	1413103	1414891	1411478	1411769	(Nylon)	1413889

Key: P = Plain K = Knurled

Transmatic Lynx 4 EHD

Note: as standard the Lynx 4EHD is supplied fitted for 1.0 - 1.2 Hard Wires

Wire Size & Type	Inlet Guide	Feed Rolls (Pack of 2)	Pressure Roll (2 req'd)	Intermediate Guide	Outlet Guide Tube Liner (115.5mm)	
0.6 - 0.8H	1413103	1409001	1411478 (P)	1411769	(1.5 ID)	1413885
1.0 - 1.2H	1413103	1409002	1411478 (P)	1411769	(2.0 ID)	1413886
1.2 - 1.6H	1413103	1409003	1411478 (P)	1411769	(2.0 ID)	1413886
1.2 - 1.6T	1413103	1411533	1411478 (P)	1411769	(2.0 ID)	1413886
1.6 - 2.4T	1413854	1409005	1411478 (P)	1411770	(3.0 ID)	1413888
2.8 - 3.2T	1413854	1409006	1411478 (P)	1411770	-	Not used
1.2 - 1.6S	1413103	1414891	1411478 (P)	1411769	(Nylon)	1413889
2.4 - 3.2S	1413854	1414892	1411478 (P)	1411770	(3.0 ID)	1413888

Key: P = Plain K = Knurled

OPTIONAL EXTRAS

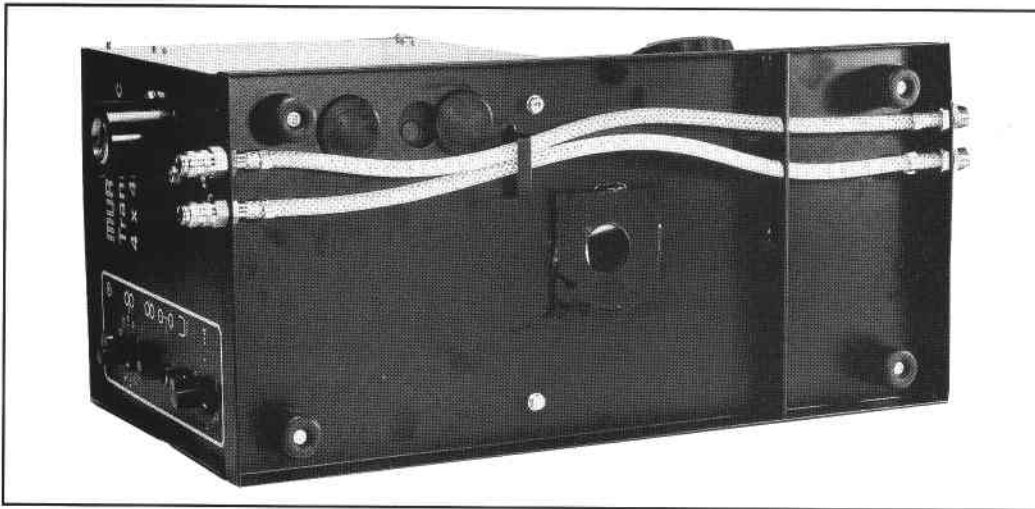

**Water Adaptor Kit
Part No. 1413647**

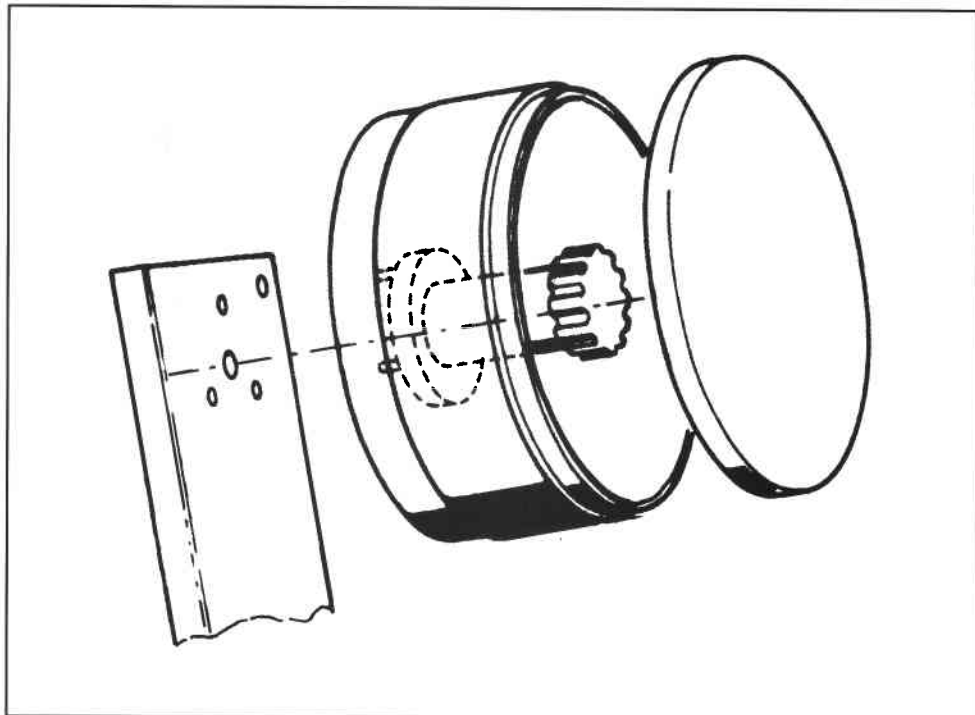

**Reel Cover Kit
Part No. 1413648**

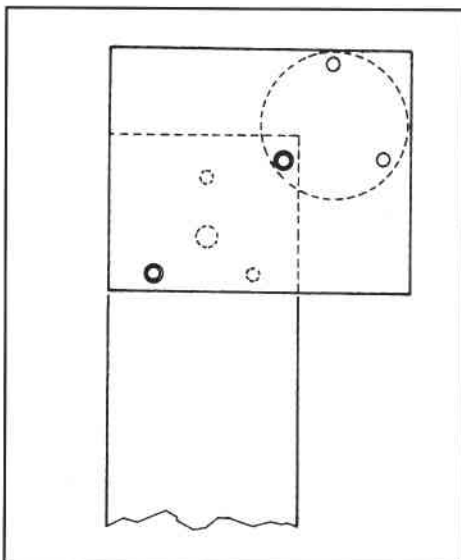

**30Kg Coil Holder
Mounting Kit
Part No. 1413649**

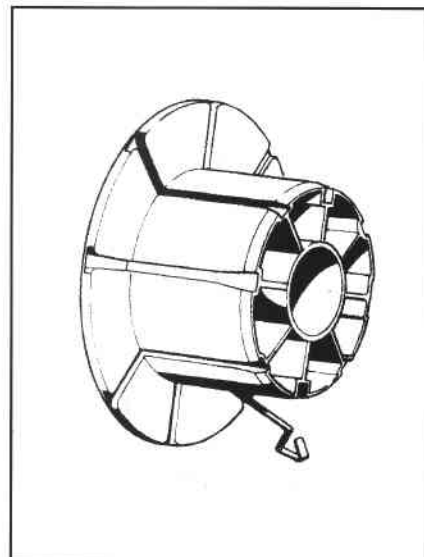

**Wire Basket Adaptor
Part No. XD 420000**

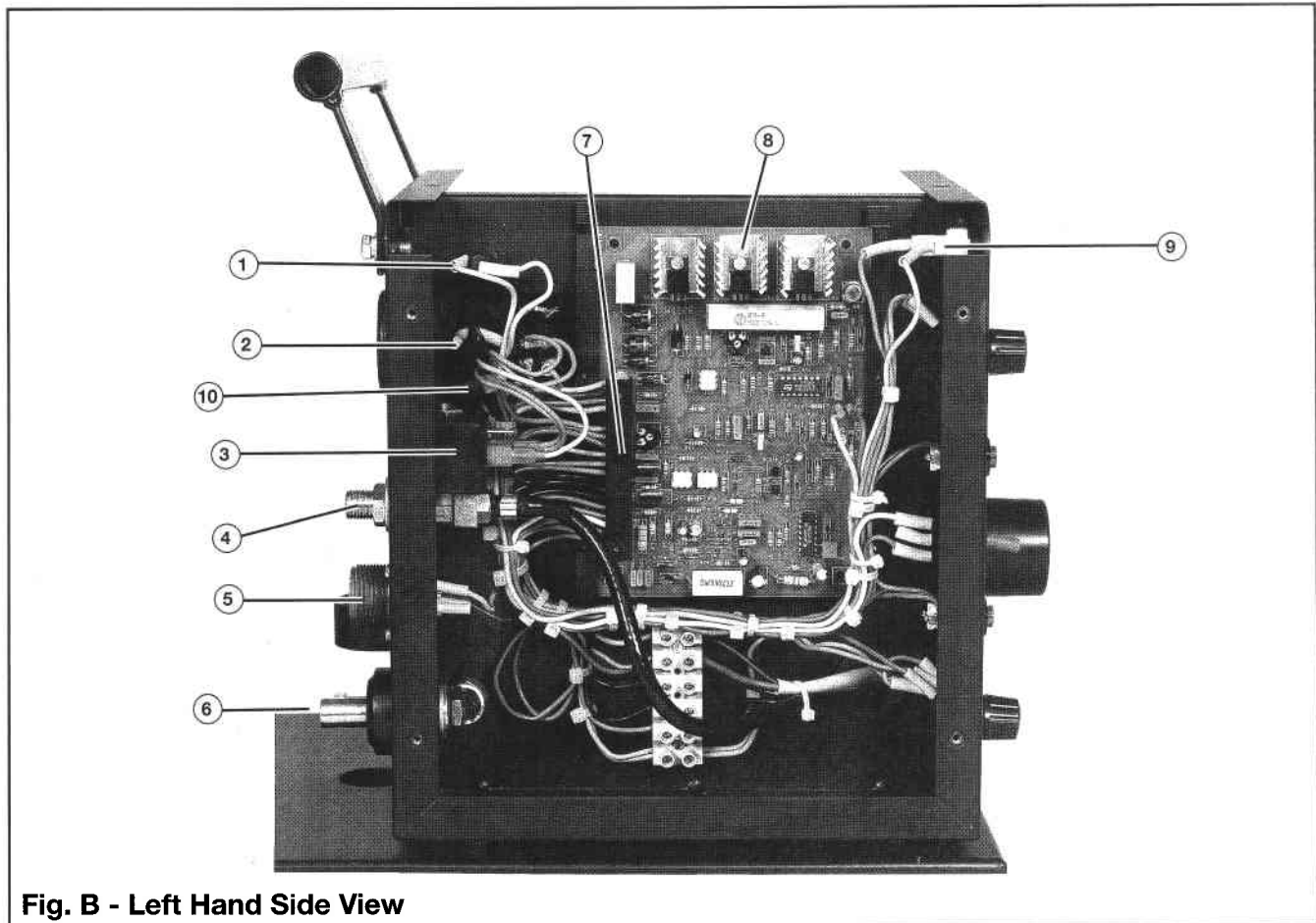
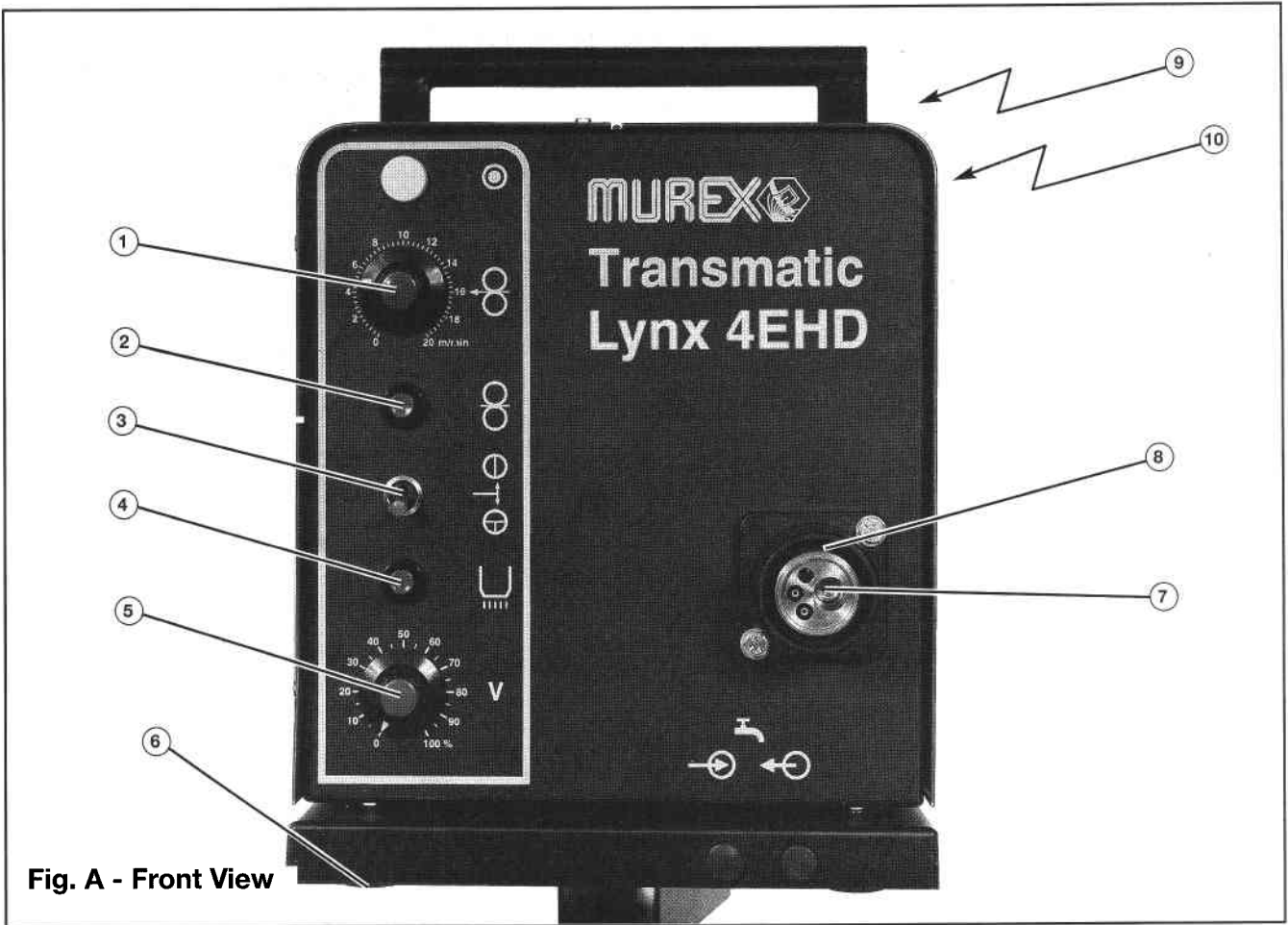

Fig. A - Front View

Item	Part No.	Description
1	1415998	Potentiometer - wire speed
-	1415999	Knob for item 1
2	1416000	Pushbutton switch - wire inch
3	1416001	Latching switch
4	1416000	Pushbutton switch - gas purge
5	1416002	Potentiometer - spot timer (2 & 4HD)
-	1416003	Potentiometer - Voltage control (4EHD)
-	1415999	Knob for item 5
6	1416004	Rubber foot (Note 1)
7	1409035	Central adaptor block inc: Switch leads
8	1411523	Bushing for item 7
9	1416005	Hub assembly complete
10	1416006	Hub nut

Note 1: *Please note, that these items must be ordered on a special order form and may be on extended delivery (contact Murex Welding Products for details)*

Fig. B - Left Hand Side View

Item	Part No.	Description
1	1416007	Fuse holder 20mm
-	1413891	Fuse Lynx 2 (Pack of 10) 8A 20 x 5mm
-	1413893	Fuse 4(E)HD (Pack of 10) 10A 20 x 5mm
2	1416007	Fuseholder 20mm
-	1413890	Fuse (Pack of 10) 1A 20 x 5mm
3	1416010	Gas solenoid valve
4	1409042	Gas bulkhead fitting
5	1411519	10 pin plug, panel mounting
-	653567	Socket for item 5 cable mounting
6	678339	Dinse plug, panel mounting
-	1380438	Dinse socket, cable mounting 50-70
7	1411435	20 way conector
8	1413842	Printed Circuit Board (control)
9	1416008	Lamp holder, lens & bulb
10	1416009	Potentiometer - burn back

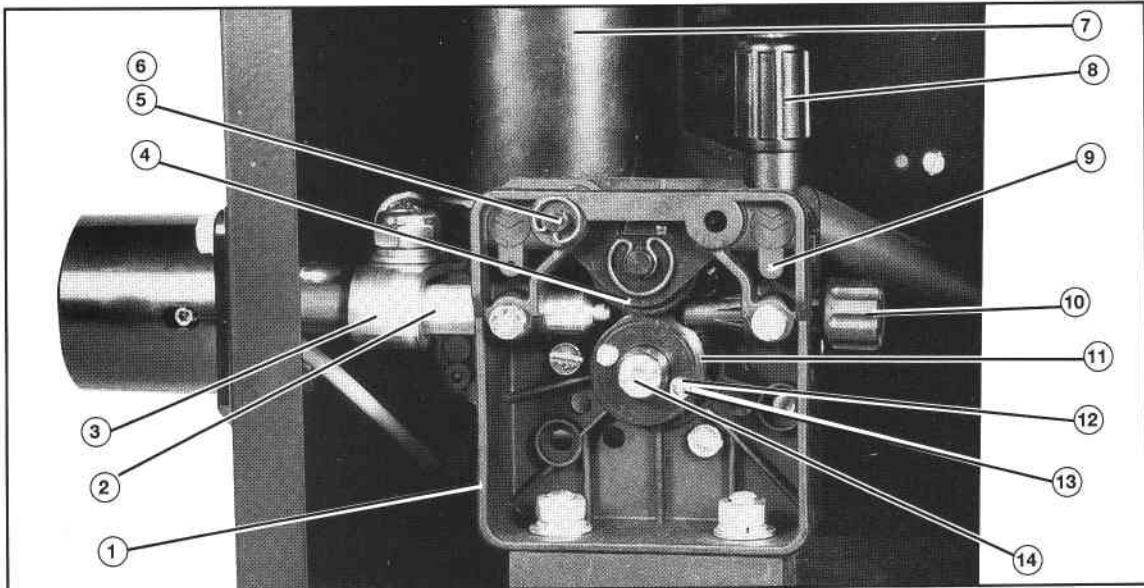

Transmatic Lynx 2

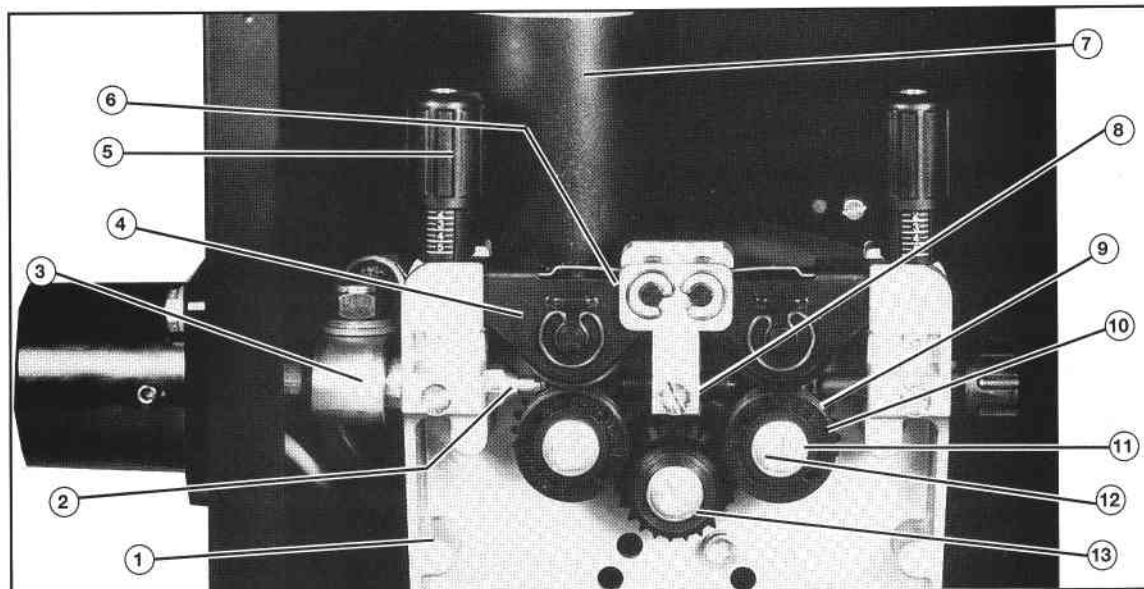

Transmatic Lynx 4HD & 4EHD

Transmatic Lynx 2

Item	Part No.	Description
1	1413874	Feedplate
2	1413871	Outlet guide tube (includes Cap nut and 'O' ring)
-	-	Outlet guide tube liner, see Consumables
3	1413453	Power clamp
4	1413451	Geared pressure roll arm, (including smooth pressure roll)
-	-	Pressure roll - see Consumables
5	1413857	Pressure arm locating pin
6	1413858	Circlip for item 5
7	1413859	Motor 42V
-	1413860	Carbon brush assembly (pair)
8	1413102	Pressure device complete
9	1413861	Locating pin for item 8
10	-	Inlet guide, see Consumables
11	1413452	Geared feed roll adaptor
12	-	Feed roll, see Consumables
13	1414800	Geared adaptor retaining screw (M3x15)
14	1413104	Feed roll retaining screw (M4x8)
-	1413870	Woodruff key
Not Shown	1413450	Feed roll block complete

Transmatic Lynx 4HD & 4EHD

Item	Part No.	Description
1	1413864	Feed roll block
2	1413873	Outlet guide tube (includes Cap nut and 'O' ring)
-	-	Outlet guide tube liner, see Consumables
3	1413453	Power clamp
4	1413865	Geared pressure roll arm 4EHD (including knurled pressure roll)
-	-	Pressure roll - see Consumables
-	1411790	Geared adaptor for pressure roll (4EHD)
-	1413857	Pressure arm locating pin
-	1413858	Circlip
5	1413866	Pressure device calibrated
-	1413861	Locating pin for item 5
6	1413867	Lifting spring
7	1413868	Motor 42V
-	1413860	Carbon brush assembly (pair)
8	-	Intermediate guide, see Consumables
9	-	Inlet guide, see Consumables
10	1411790	Geared adaptor for feed roll
11	-	Feed roll, see Consumables
12	1413104	Feed roll retaining screw (M4x8)
-	1413391	Feed roll axle
13	1411791	Drive gear
-	1413870	Woodruff Key (Motor)
Not Shown	1413876	Feed roll block complete

NOTES



Murex Welding Products Limited
Hertford Road, Waltham Cross,
Herts. EN8 7RP. England
Telephone: (01992) 710000
www.murexwelding.co.uk

Pt. No. 100572
Issue 1