

KEPUNI A widely trusted manufacturer in automation field.

ORBITAL WELDING MACHINE

Customized

Installation

After-sales

Training

Integrated service



**XD-20Pro****XD-20w**

On-demand customization

Orbital welding machine

The power supply of the orbital welding machine is composed of the control system, the power supply system and the cooling water tank. This power supply is specially designed and manufactured for pipe welding, which is used in semiconductor, chemical, food, medicine, electronic pipeline, new energy, heat exchanger, refrigeration equipment, water treatment, laboratory and other industries.

Advantages

- German rail type pipeline welding process, welding qualification rate is high
- High definition color 10 inch industrial grade display, can run continuously all day
- Siemens PLC control system ensures fast operation of welding process parameters
- Dual cooling system, equipment running without noise, improve the welding head duty ratio
- Expert welding data accumulation, automatic generation of intelligent expert parameters
- Real-time monitoring, multiple alarms, timely identification of improper operations
- One-click printing and automatic printing with built-in mini maintenance-free printer
- Add USB interface to realize welding data import and export

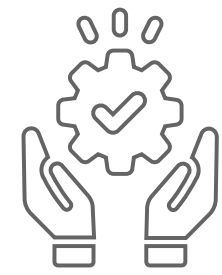

Technical parameter

Model	XD-20W	XD-20PRO
Duty cycle	200A 60% /155A 100%	
Floating voltage	90V	
Input voltage	AC220V±10% 50Hz/60Hz	
Power	4.5 KVA	
Welding gun cooling	Built-in circulating water cooling	
Screen	10 inch touch screen	
Partition Free Space	12	
Insulation grade/Protection grade	F/IP21	
Welding current	5-200A	
Programmable memory	99	600
Tank Volume	4L	4L
Weight	33KG(Water inclusion 4L)	30KG(don't contain water)
Machine size	512*355*350mm	560*360*365mm
Control function	DC/pulse current control / gas control/rotary motion /auto printing/water cooling control	
Defensive function	1.Overvoltage, overload, leakage, arc failure and tungsten needle short circuit protection 2.Water level alarm, water flow alarm, welding torch short circuit alarm, motor current alarm 3.Welding speed detection, arc pressure detection	
Upgrading of function	<ul style="list-style-type: none"> * Argon flow setting * Detection and control * Water flow and temperature detection * Automatic welding gun recognition * Welding status indicator 	<ul style="list-style-type: none"> * Import and export recipes/can connect the mouse * Heat dissipation channel optimization, better heat dissipation performance



Closed tube welding gun

Designed and developed special weld head for all position automatic welding of various pipe fittings.

- ✔ High duty cycle
- ✔ Quick replacement without obstacles
- ✔ Lightweight and durable
- ✔ Convenient and efficient operation

Model	XD-40	XD-80	XD-120	XD-170
Main power supply	XD-20Pro / XD-20W			
Welding material	Carbon steel/stainless steel/titanium alloy, etc			
Welding Diameter Range/mm	6.35-38.1	10-76.2	19-114.3	38.1-168
The Maxium Wall Thickness/mm	0.5-2.5	0.5-3	0.5-3.0	0.5-3.0
Torch rotation speed(rpm)	0.16~2.8	0.1~1.8	0.1~1.8	0.1~1.8
Welding Heads Cooling	Water cooling			
Protective gas	Argon			
Weight(kg)	3.5	5	6.5	9.5
Dimension(mm)	381.5*120*48	438.5*172.5*52	513*226.5*48	650*331.5*163

Enclosed welding torch case diagram

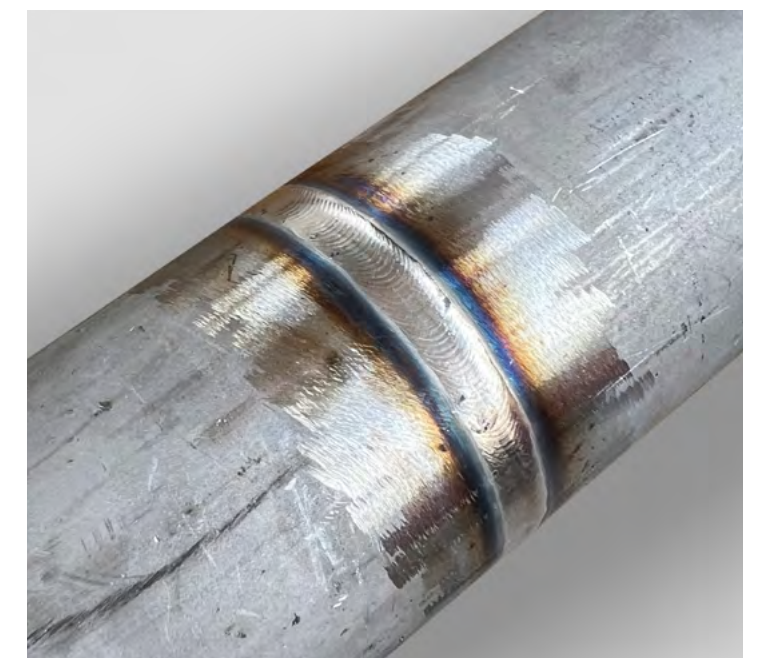
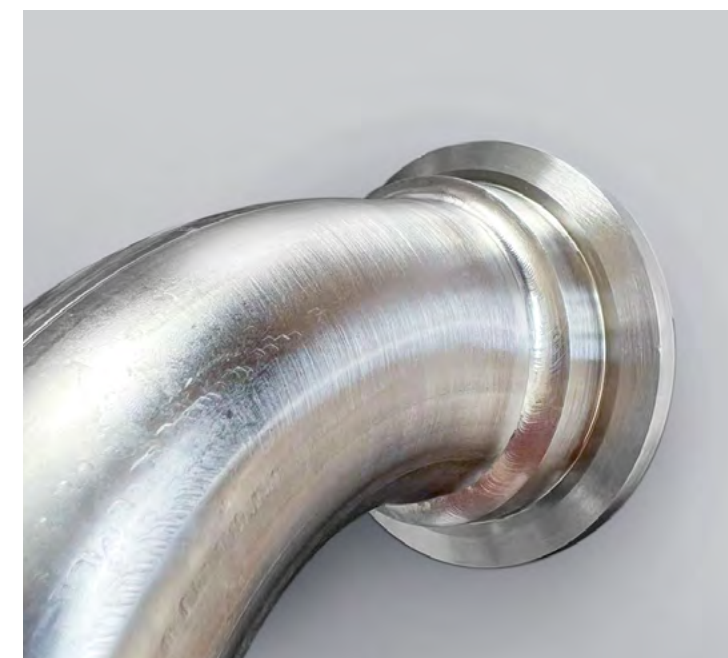
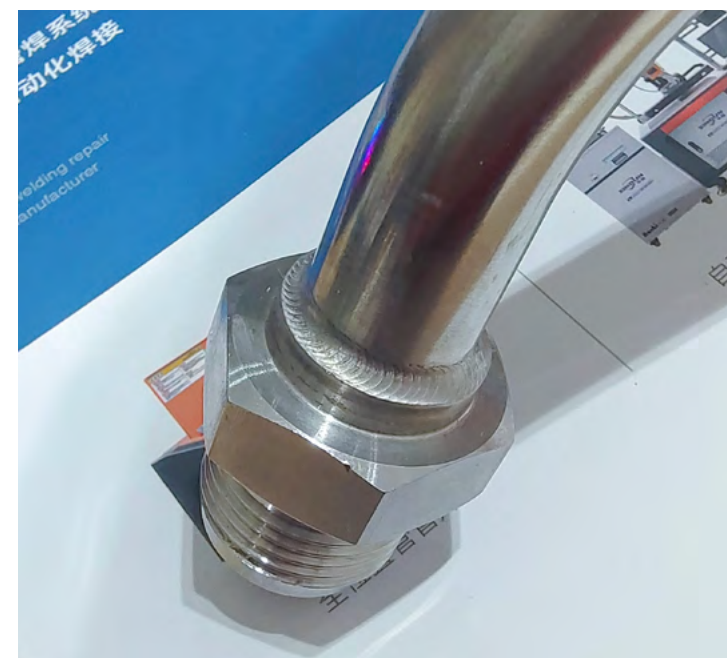
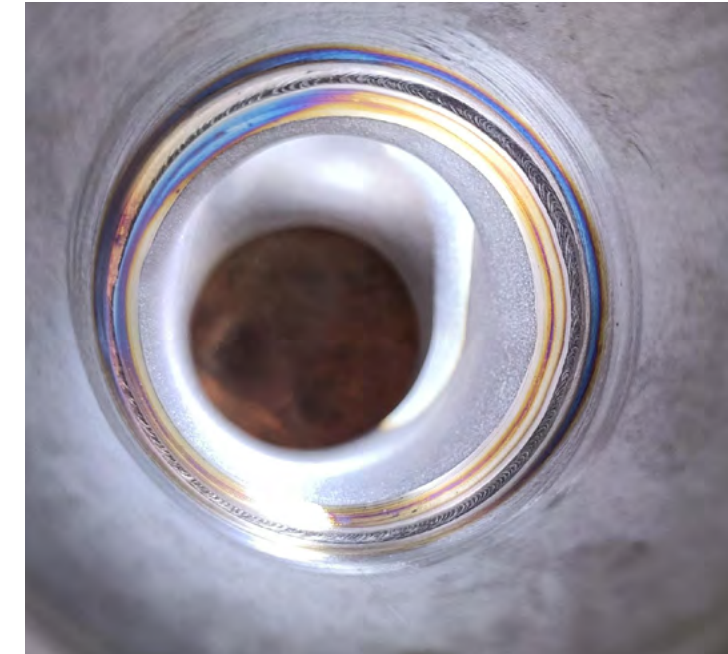



Split tube welding gun

Micro welding torch, small size is extremely space-saving, one hand flexible grasp, welding materials are mainly carbon steel/ stainless steel/titanium alloy

Miniature welding guns are designed for confined Spaces

≥ 6mm
Straight-line distance

Model	XD-5H	XD-10H	XD-8H	Eccentric welding
Main power supply	XD-20Pro / XD-20W			
Welding material	Carbon steel/stainless steel/titanium alloy, etc			
Welding Diameter Range/mm	3.175-15.88	6.35-25.4	6-12.7	3.175-15.88
The Maxium Wall Thickness/mm	0.5-1.5	0.5-1.5	0.5-1.5	0.5-1.5
Torch rotation speed(rpm)	0.6-9.0			
Welding Heads Cooling	Water cooling[XD-8H forced air cooling]			
Protective gas	Argon			
Weight(kg)	1.3	1.8	4	6
Dimension(mm)	155*70*50	170*100*55	255*66*29	169*74*167
Straight-line distance	≥19	≥19	≥6	Thick edge 6/ thin edge ≥19

Micro-tube welding case

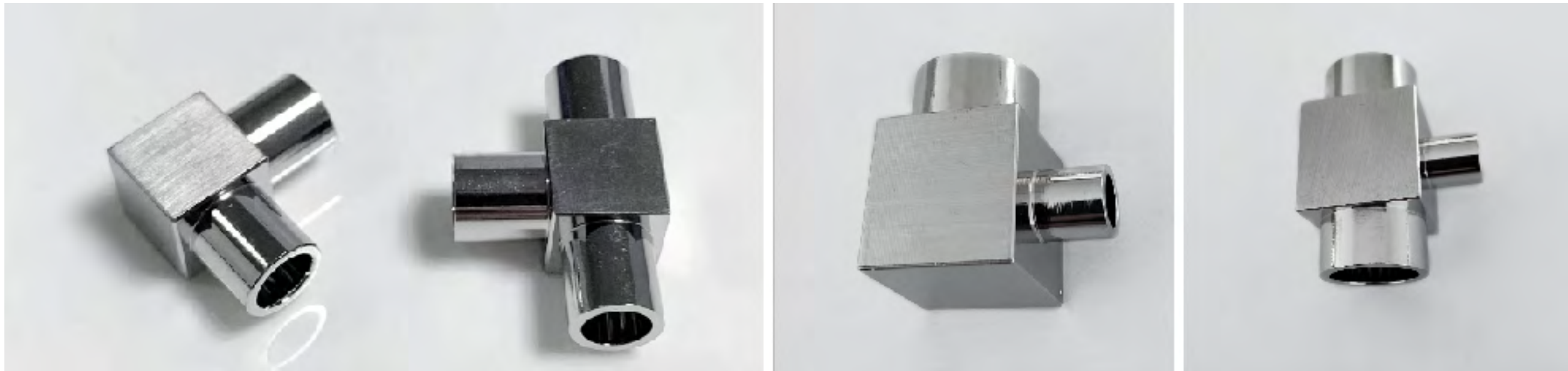

90° elbow

T-joint

90° reducing bend

T-tube reducer joint

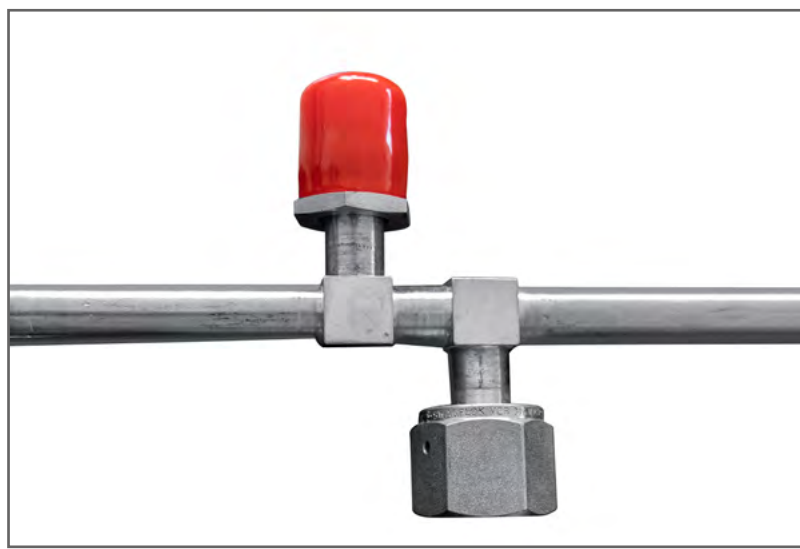
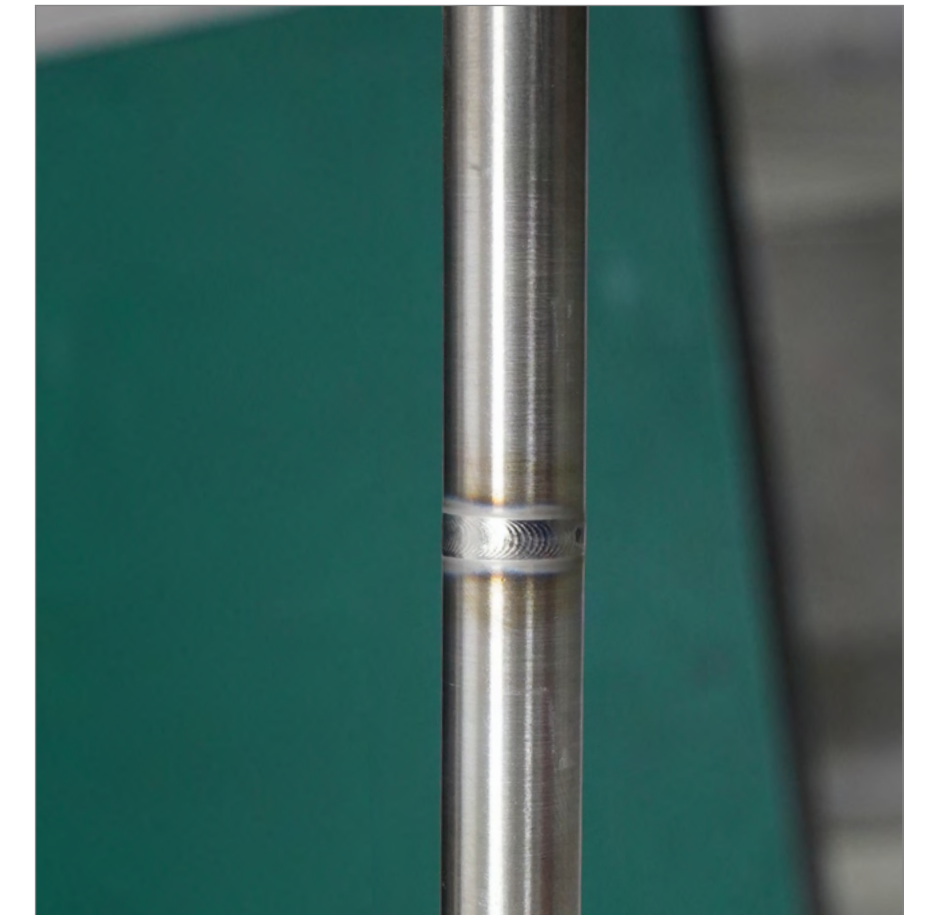
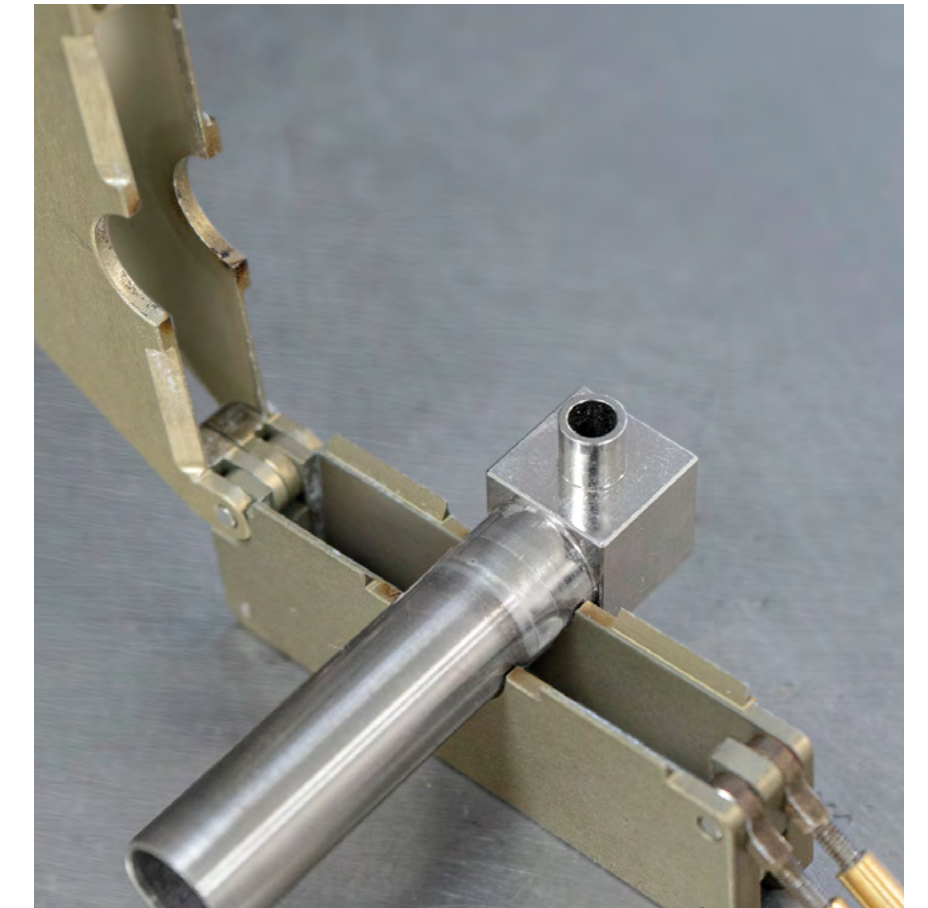

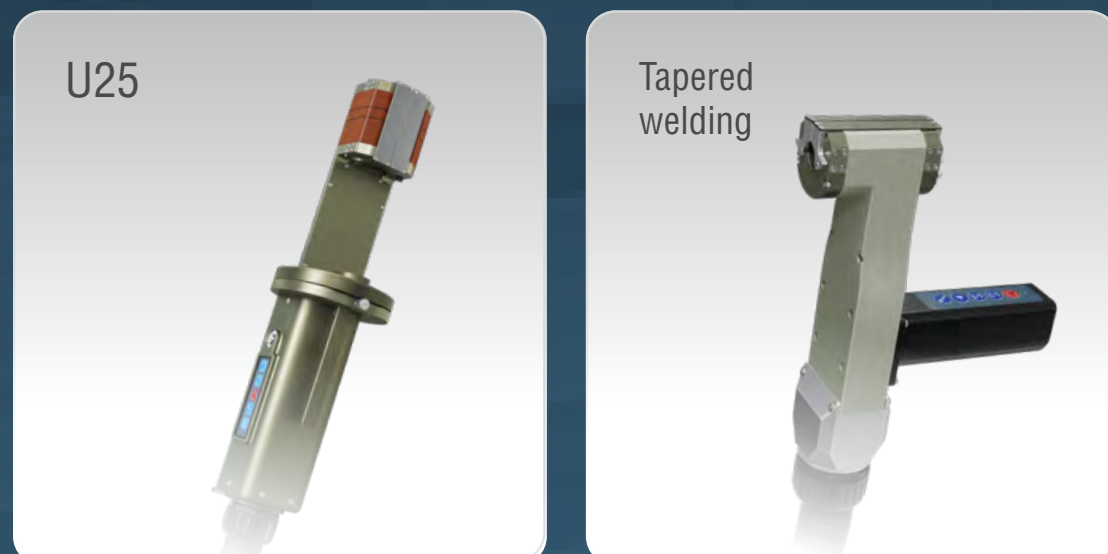

U-tube welding gun

Suitable for heat exchanger, refrigeration industry, small welding head, welding materials are mainly carbon steel/stainless steel/titanium alloy.

Model	U12	U16	U21	U25	Tapered welding
Main distribution power	XD-20W / XD-20Pro				
Weldable material	Carbon steel/stainless steel/titanium alloy, etc				
Tube to tube/mm	≥32	≥35	≥42	≥52	≥46
Straight line section/mm	≥35	≥35	≥35	≥41	≥40
Elbow straight section/mm	≥38	≥40	≥40	≥40	/
Pipe diameter range/mm	9-12.7	12.7-15.88	15.88-21	19-25	12.7-21
Maximum wall thickness	0.5-1.5mm				
Tungsten electrode	2.0mm{U25-2.4}				
Torch cooling	water-cooling				
Protective gas	Argon				
Weight/kg	6.5	7	7.8	8	6
Size/mm	393.5*80*95	382*80*95	400*80*95	415*110*126	203*180*73

Application industry

Mainly used in chemical, food, medicine, boiler, military, nuclear power, heat exchanger and other industries

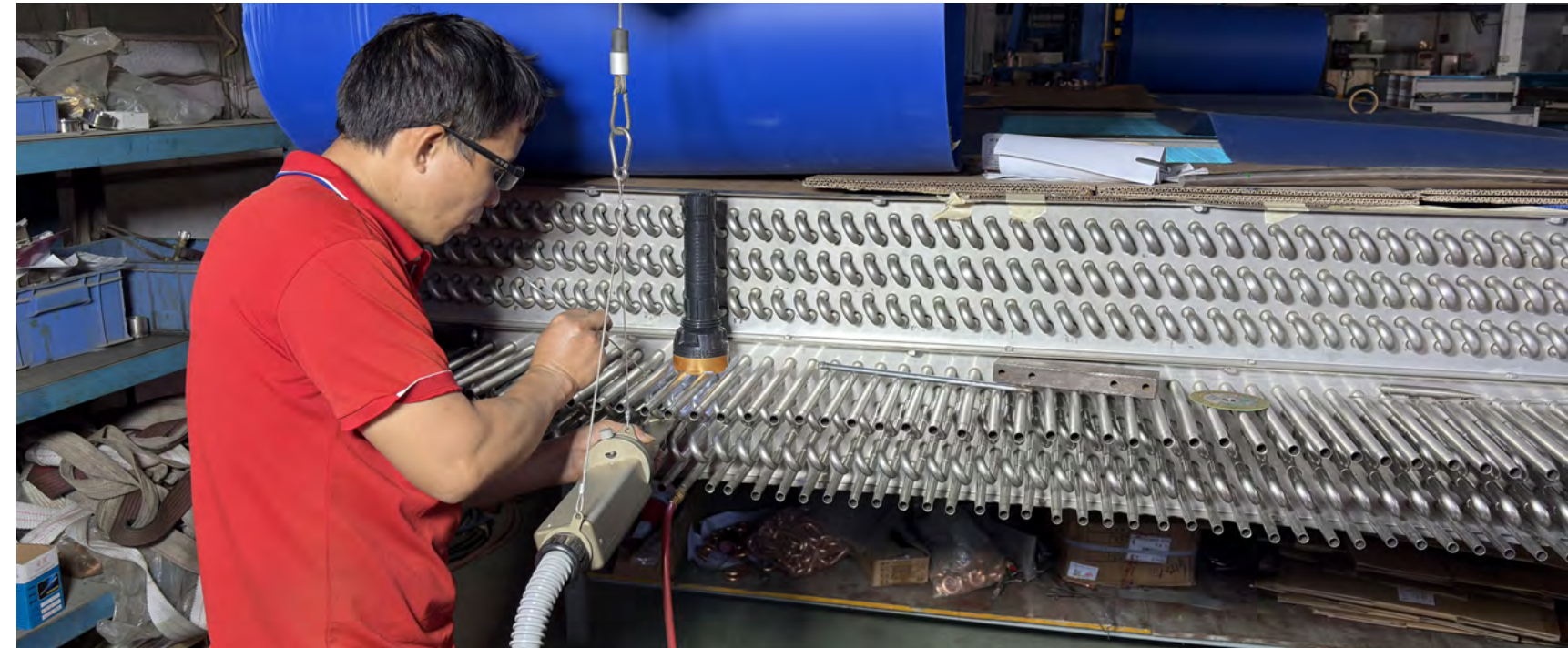

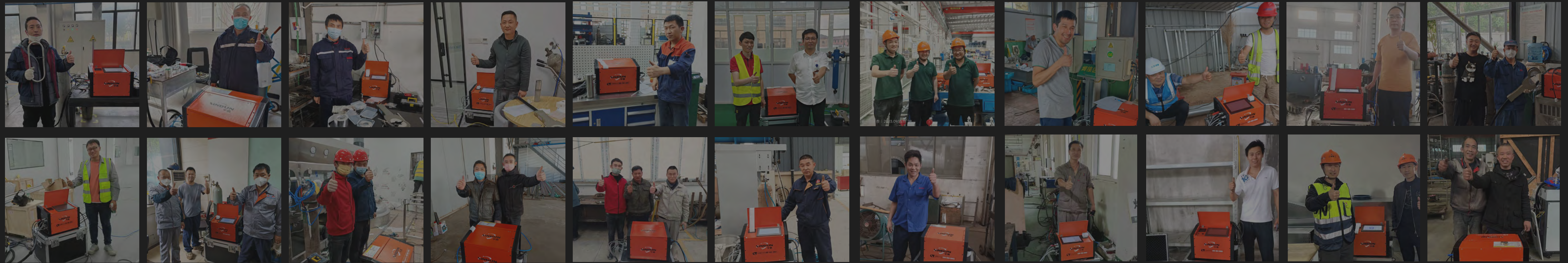

Customer's affirmation is our driving force

Recruitment of global agents

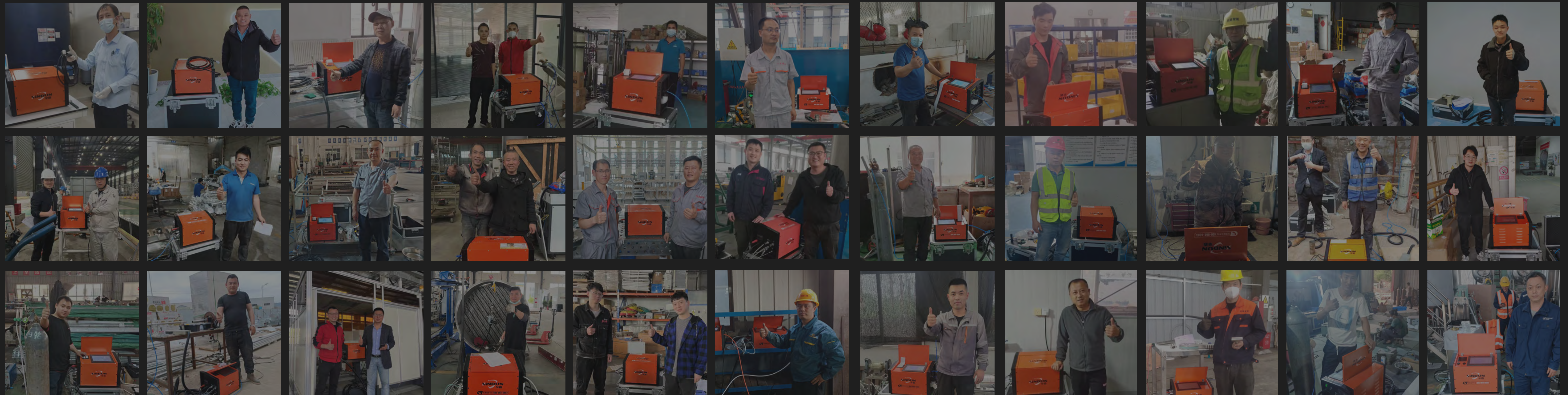



Company introduction

Research-manufacturing-sale-after sale integrated enterprise

Shanghai Chuanli Industrial Co., Ltd. is a high-tech enterprise with technological innovation as its core competitiveness, and is a mature integrated enterprise integrating research and development, manufacturing, sales and service.

Brand strength

The company is headquartered in the international metropolis of Shanghai, covering an area of approximately 8 000 square meters, It has offices in Tianjin, Guangzhou, Chongqing, Anhui, and Jiangsu. In recent years, the company has been actively expanding its online, offline and overseas markets, establishing brand value. The machines are widely sold to developed countries such as the United States, Japan, Singapore, etc, have gained more recognition from enterprises in the international market.

The company's core R & D team has rich R & D experience in the field of automation, has always been oriented to meet customer needs, seeking R & D oriented methods, and is committed to providing customers with suitable and reliable products. The company has independent research and development rights of products including track welding machine/tube plate welding machine/automatic welding platform/handheld laser welding machine/automatic shaft repair equipment, etc., to realize the concept of intelligent products and automation.

10000

Physical factory



300

Enterprise staffs



50⁺

Utility patent



50⁺

Research staff



Condition of business

Non-trading company with offline physical factories

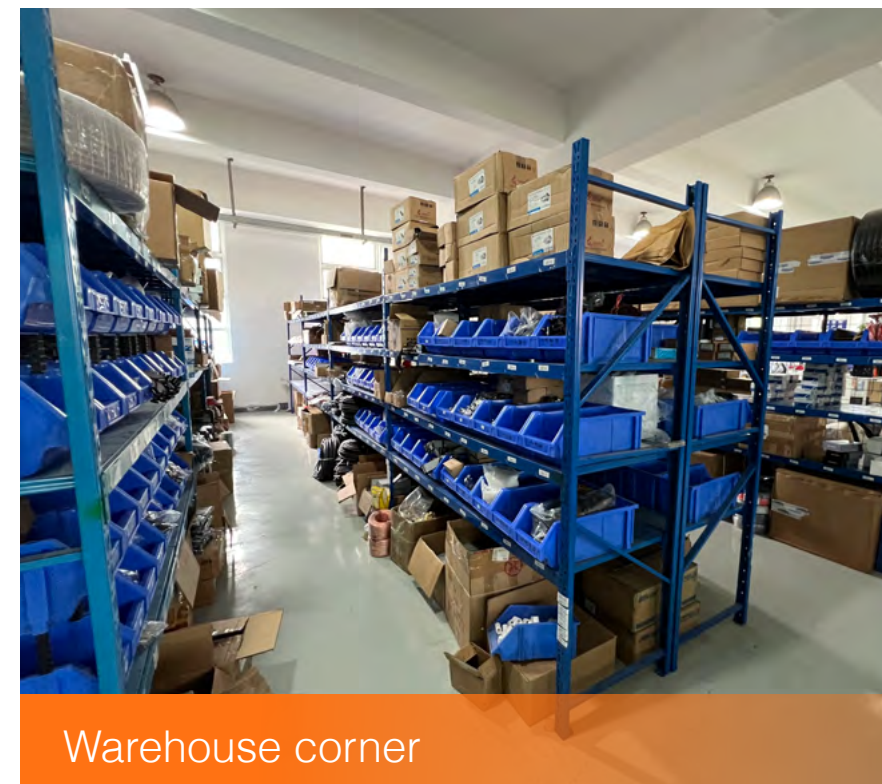
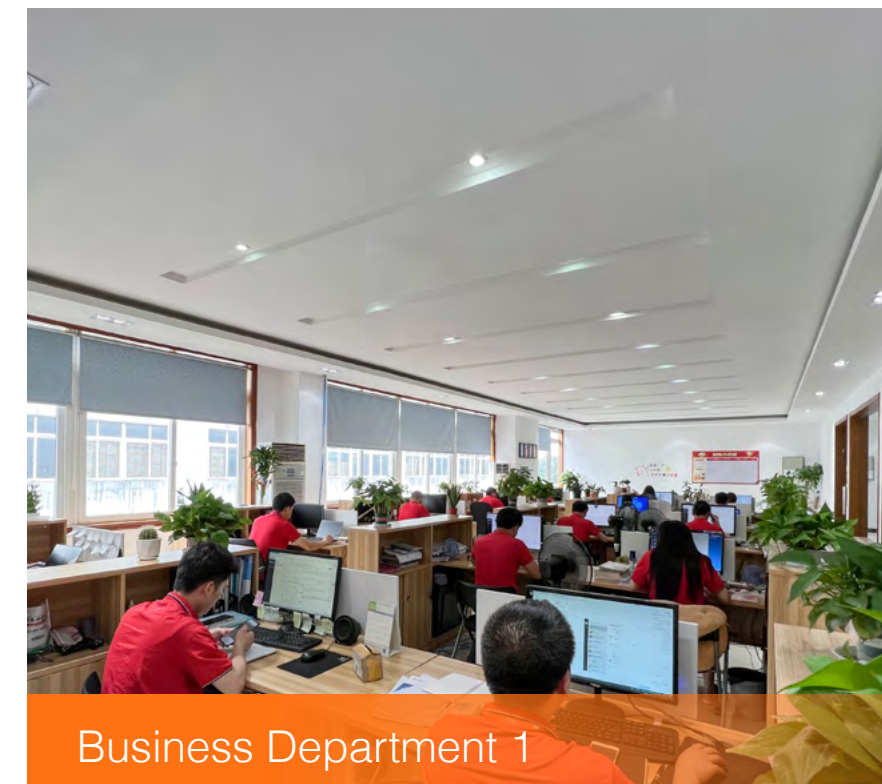

Qualification certificate

We insist on 'speaking with authority and quality'

Utility model patent certificate

As of July 2024, the company has obtained dozens of utility model patents

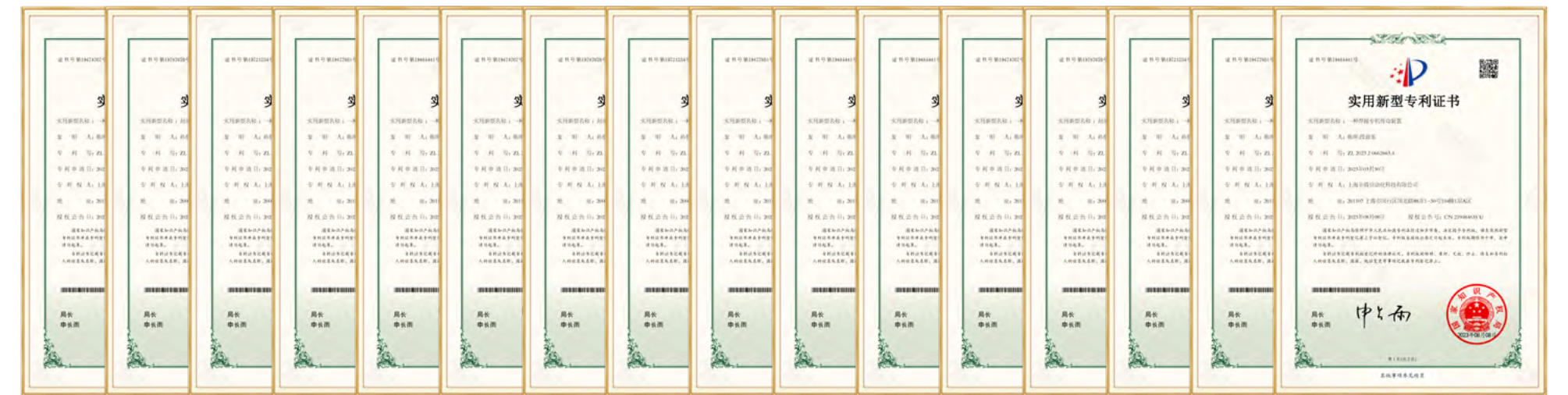

Software authoring certificate

Software product certificate



National high-tech enterprises

ISO9001-ISO45001-ISO14001

Eu CE certification



After-sale service

Details determine quality, and quality comes from professional technology

- Different configuration warranty period is different, the details to consult the sales personnel.
- During the warranty period, Xindun is responsible for free replacement of parts and services for any damage or damage caused by the quality of the equipment, except for conventional consumables (protective lenses, copper mouths, etc.) and those responsible for illegal operation.
- KEPUNI provides lifetime maintenance services for the products provided, and provides daily consultation and guidance related to the equipment at any time. After the warranty period, it still provides users with extensive and preferential technical support and spare parts supply.
- 24-hour customer service online, ready to help you solve problems
- KEPUNI promises to timely inform users of software upgrades and provide free software upgrade services.
- KEPUNI has sufficient spare parts and accessories, which can timely provide technical services and spare parts services to users to meet the needs of equipment maintenance.



Tel
+86 16621108513



Email
info@kepuniwelder.com



Web
www.kepuniwelder.com



Address
No.688 Jiaqian Rd, Jiading District, Shanghai