

Technical Specifications – 1000 KG

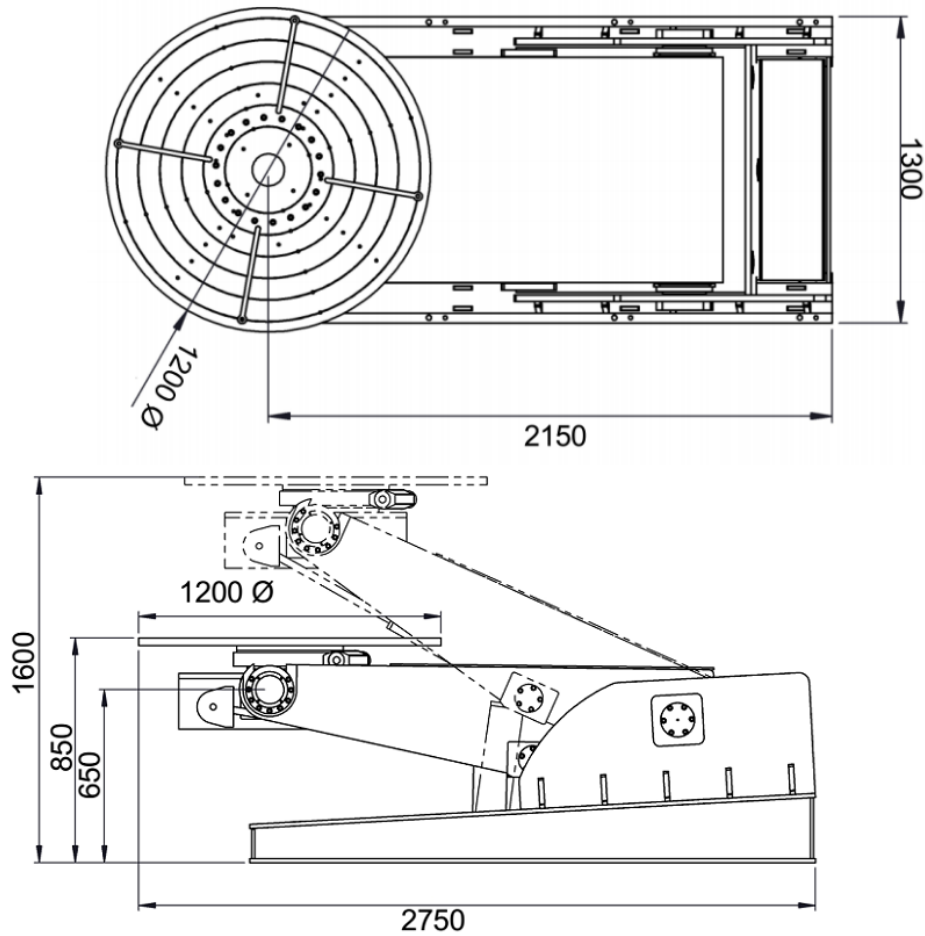

Max. Load (N)	10000
Axis Eccentricity	150mm for Rotation and Tilting
Rotation Speed (rpm/min)	Min 0,15 – Max 1,5 @ 5 Hz – 50 Hz Range
Rotation Torque (kg.m)	150
Rotation Motor	1 x 0,75 Kw AC Motor
Min – Max Height	850 mm – 1600 mm
Tilting Angle	120°
Tilting Speed from 0 to 120	60 second
Tilting Speed from 0 to 120	N/A
Tilting Torque (kg.m)	N/A
Tilting	2 x Hydraulic Cylinders
Driver	AC 1.5 Kw
Face Plate Diameter	1200 mm
Fixing Slots	4 T-Slots / M16 (it can be M18 or anyelse)
Control Device	Standing Control Panel
Incoming Supply	380V/400V, 3Ph, 50Hz @ 5 – 50 Hz
Applicable Optional	Hand Pendant & Foot Pedal
Colour	RAL6025 GREEN/ Texture Painting
Welding Torch Holder	No
Shipping Dimension & Weight	Width 1450mm x Length 3000mm x Height 1250mm / 1450 Kg