



# TRI TOOL INC.

## TRI TOOL INTERNATIONAL INC.

3806 Security Park Drive., Rancho Cordova, CA 95742-6990 U.S.A. 916-351-0144 800-345-5015 FAX 916-351-0372 [ttcustserv@aol.com](mailto:ttcustserv@aol.com) [www.tritool.com](http://www.tritool.com)

TRI TOOL INC.  
TECHNICAL SPECIFICATION  
MODEL 212B BEVELMASTER™ ELBOW MANDREL  
OCTOBER, 1999

### MODEL 212B BEVELMASTER™ ELBOW MANDRELS

The Model 212B Elbow Mandrel is provided to be used in conjunction with a Model 212B BEVELMASTER™ in short perch length applications. Only .75" (19.1mm) of bore length is required for mounting to fit within most elbows and weld neck flanges.

The Model 212B Elbow Mandrel Kit comes complete with:

- A. Mandrel Sub Assembly
- B. Plug
- C. Push Rod Assembly
- D. #1 Elbow Mandrel Head Assembly
- E. #2 Elbow Mandrel Head Assembly
- F. #3 Elbow Mandrel Head Assembly
- G. Carrying Case
- H. All required operator's wrenches
- I. Operator's Manual

### Design and Operation Features:

1. The elbow mandrel can be set up in the bore before the 212B is installed onto the mandrel shaft.
2. The mandrel heads have interchangeable contact pins to allow configuring mandrel sub-assemblies for different inside diameter mounting ranges.
3. A perch length of only .75" (19.1mm) is required.
4. Self-centering, push rod actuated locking.

Specifications:

1. Pipe Holding Capacities:

a. Basic Pipe Sizes

\*4" schedule 5 through schedule 160

\*All schedules of 5" through 12" pipe

b. Inside Diameter Mounting Range:

3.31" (84.1m) through 13.12" (333.2mm)

\*Not recommended for schedule 40 and lighter pipe.

2. Mounting:

a. .75" (19.1mm) axial length, 3 pin contact.

4. Material:

a. Hardened steel contact pins.

5. Reference envelope drawing No. 77-1214

Optional Accessories:

A. Adjustable Centering Pin Kit for centerline adjustment of Mandrel Assembly. (P/N 05-0357)

B. Squaring Plate Kit (P/N 05-1329)

Spare parts and standard tool bits are available from stock.

Engineering design services for custom tool bits and special function modifications are available from the factory.

All Tri Tool and allied equipment products are subject to design improvements and specification changes at any time with no obligation to units already sold.

Warranty (limited), parts and/or equipment are warranted against defects in material and workmanship for a period of one year from date of purchase. Full details supplied on request and/or with tools.

Filter, regulator, lubricator required to protect warranty on air powered tools.

Head Assy P/N	Contact Pin P/N	ID Mounting Range		Pin Length
		"A" dia minimum	"B" dia maximum	
21-0245	32-0318	3.31" (84.1 mm)	4.16" (105.7 mm)	1.575" (40.0 mm)
	32-0319	4.15" (105.4 mm)	5.06" (128.5 mm)	2.028" (51.5 mm)
	32-0320	5.06" (128.5 mm)	5.97" (151.6 mm)	2.481" (63.0 mm)
21-0246	32-0321	5.91" (150.1 mm)	6.82" (173.2 mm)	2.909" (73.9 mm)
	32-0322	6.82" (173.2 mm)	7.73" (196.3 mm)	3.362" (85.4 mm)
	32-0323	7.73" (196.3 mm)	8.64" (219.5 mm)	3.815" (96.9 mm)
	32-0324	8.64" (219.5 mm)	9.54" (242.3 mm)	4.268" (108.4 mm)
	32-0325	9.49" (241.0 mm)	10.39" (263.9 mm)	4.696" (119.3 mm)
21-0247	32-0326	10.39" (263.9 mm)	11.30" (287.0 mm)	5.149" (130.8 mm)
	32-0327	11.30" (287.0 mm)	12.21" (310.1 mm)	5.602" (142.3 mm)
	32-0328	12.21" (310.1 mm)	13.12" (333.2 mm)	6.055" (153.8 mm)

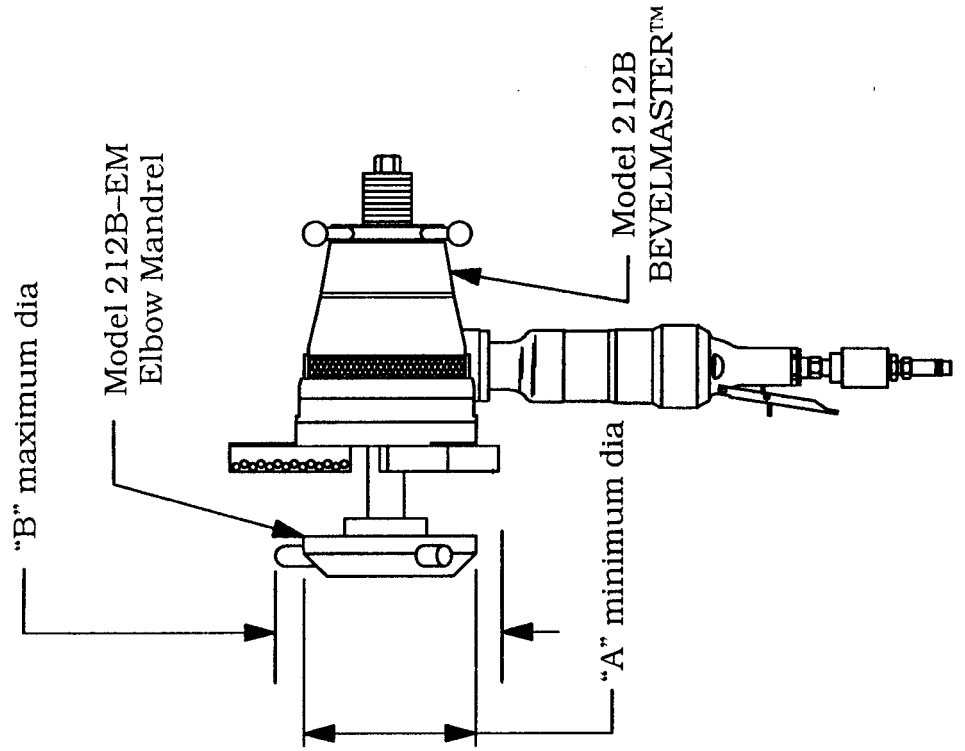

**TRI TOOL INC.**  
3806 SECURITY PARK DRIVE, RANCHO CORDOVA, CA 95742-6990

**Envelope Drawing**  
**Model 212B-EM Elbow Mandrel**

CONTRACT NO. \_\_\_\_\_

APPROVALS: \_\_\_\_\_ DATE: 1/12/93

DRAWN: PFAFMAN

CHECKED: \_\_\_\_\_

ISSUED: \_\_\_\_\_

SIZE: **A** FSCM NO. \_\_\_\_\_ DWG. NO. **77-1214** REV. \_\_\_\_\_

SCALE: None SHEET 1 of 1

**DO NOT SCALE DRAWING**

**COMPANY CONFIDENTIAL**  
 PROPRIETARY PROPERTY OF TRI TOOL INC.  
 NO REPRODUCTION, USE, OR DUPLICATION OF THE  
 DESIGNS SHOWN HEREON IS PERMITTED WITHOUT  
 EXPRESS WRITTEN CONSENT FROM TRI TOOL INC.  
 3806 SECURITY PARK DRIVE, RANCHO CORDOVA, CA 95742-6990  
 COPYRIGHT TRI TOOL INC.