

# F20 & F20 Air

## Flip front fixed shade welding helmet



The ESAB F20 has a 'flip up' front in to which a welding glass is fitted. There is also a protective plastic lens that gives facial protection when the front is in the up position. Welding glass 10 DIN included in all helmets. CE-approved according to EN175.

- 60 x 110 mm & 90 x 110 mm flip front options
- Lightweight shell with comfort headgear
- Changeable DIN lenses
- Inside viewing visor
- Respiratory option with ESAB PAPR

Visit [esab.com](http://esab.com) for more information.

### Process

- SMAW/MMA (Stick)
- GMAW (MIG/MAG)
- GTAW (TIG)
- Oxy Fuel Cutting
- Plasma Cutting
- PAW - Plasma Arc Welding



*Internal viewing visor*



*F20 Air*

# F20 & F20 Air

## Specifications

Viewing Area	90mm x 110mm & 60mm x 110mm
Lens Shade	DIN 10
Standards	CE, ANSI, CSA, ASNZS
Weight - 60 x 110	560g
Weight - 90 x 110	580g
Weight - 60 x 110 Air	720g
Weight - 90 x 110 Air	740g

## Ordering Information

F20 60 x 110	0700000426
F20 90 x 110	0700000427
F20 Air 60 x 110	0700000428
F20 Air 90 x 110	0700000429
1. Main Shell F20	0700000509
2. Visor Flip F20 60 x 110	0700000510
2. Visor Flip F20 90 x 110	0700000511
3. Plastic Cover Lens 60 x 110	0160307001
3. Plastic Cover Lens 90 x 110	0160307004
4. Inside/Outside Cover Lens 60 x 110, 90 x 110	0700000252
5. Lens Buckle 90 x 110	0700000256
5. Lens Buckle 60 x 110	0700000255
6. Filter Lens 90 x 110	0760031633
6. Filter Lens 60 x 110	0160292003
7. Head Gear	0700000415
8. Sweat Band	0700000414
9. Head & Face Seal F20	0700000522
10. Headgear Including Airduct	0700000420
11. Sweatband for Air	0700000274

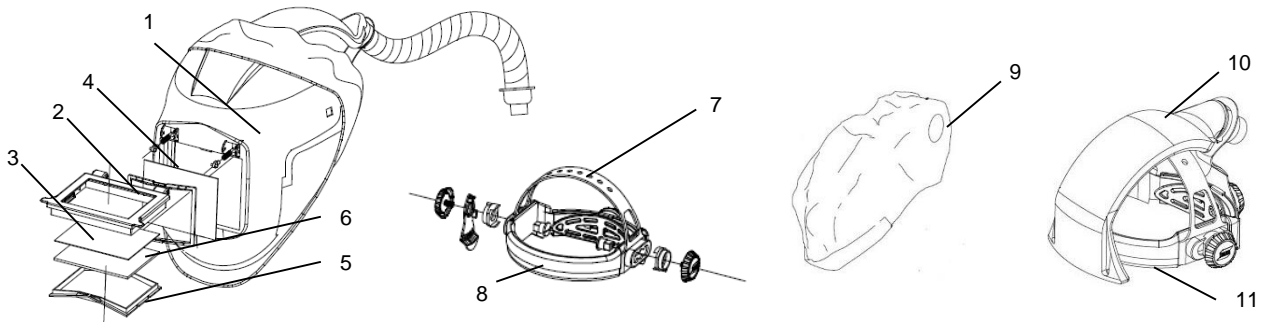

ESAB / esab.com

