

**WORLD LEADERS IN THE DESIGN,
MANUFACTURE & DISTRIBUTION OF AUTOMATED
WELDING SYSTEMS AND ACCESSORIES
CUT COSTS, IMPROVE QUALITY, AND INCREASE EFFICIENCY WITH THESE PROVEN
GULLCO PRODUCTS**



KAT® SYSTEMS	MOGGY®	WELD PREP	OVENS	CERAMIC BACKING
<ul style="list-style-type: none"> Oscillators Torch indexers Flex & Rigid KAT® Programmable Travel Carriages Seam Trackers Bridge Units Circle Cutting System 	<ul style="list-style-type: none"> Trackless Fillet & Butt Welding, Stitch Welding control Radial Oscillation Control 6" V-groove Track Available 	<ul style="list-style-type: none"> Bevellers Positioners Grippers Kamel Pipe Turning Rolls 	<ul style="list-style-type: none"> Flux Rebake Flux Holding Flux Hoppers Electrode Stabilizing 	<ul style="list-style-type: none"> KATBAK® Ceramic Weld Backing Impart Uniform X-Ray Quality Back Beads Eliminate Costly Grinding & Re-welds Knuckle Joints for Use On Flat or Curved Surfaces

CONTACT GULLCO OR YOUR GULLCO DISTRIBUTOR TODAY FOR INFORMATION ON ANY OF THESE PRODUCTS

KAT, KBM, MOGGY, KATBAK & SAM are registered trademarks of Gullco Enterprises Limited

SPECIFICATIONS ARE SUBJECT TO CHANGE WITHOUT NOTICE

Distributed by:

www.westermans.com
welding@westermans.com

WWW.GULLCO.COM

KA-11-01

GULLCO		
CANADA - GULLCO INTERNATIONAL LIMITED	Phone: 905-853-4140	Fax: 905-853-4138 e-mail: sales@gullco.com
U.S.A - GULLCO INTERNATIONAL INC.	Phone: 440-439-8333	Fax: 440-439-3634 e-mail: ussales@gullco.com
EUROPE - GULLCO INTERNATIONAL (U.K.) LIMITED	Phone: +44 1257-253579	Fax: +44 1257-254829 e-mail: sales@gullco.co.uk
AUSTRALIA - GULLCO INTERNATIONAL PTY LIMITED	Phone: 61 (0)7 3348 5515	Fax: 61 (0)7 3348 5510 e-mail: aussales@gullco.com
INDIA - GULLCO INTERNATIONAL INDIA PVT LIMITED	Phone: 91-20-95290382	Fax: 91-20-26839956 e-mail: india.ig@gullco.com
CHINA - GULLCO INTERNATIONAL SHANGHAI LIMITED	Phone: +8621-50460341	Fax: +8621-50463554 e-mail: gauntech@sh163.net
SINGAPORE - GULLCO INTERNATIONAL LIMITED	Phone: +65-9385-4468	e-mail: benny.lim@gullco.com
LATIN AMERICA - GULLCO INTERNATIONAL LIMITED	Phone: 55-11-9485-1336	e-mail: roperio.macedo@gullco.com
STUCC GMBH & CO. KG SCHWEISSTECHNIK - GERMANY	Phone: (02 03) 72 94 95	Fax: (02 03) 72 94 90 e-mail: info@stucc-schweisstechnik.de



WELDING AND CUTTING CARRIAGE ACCESSORIES - KAT®

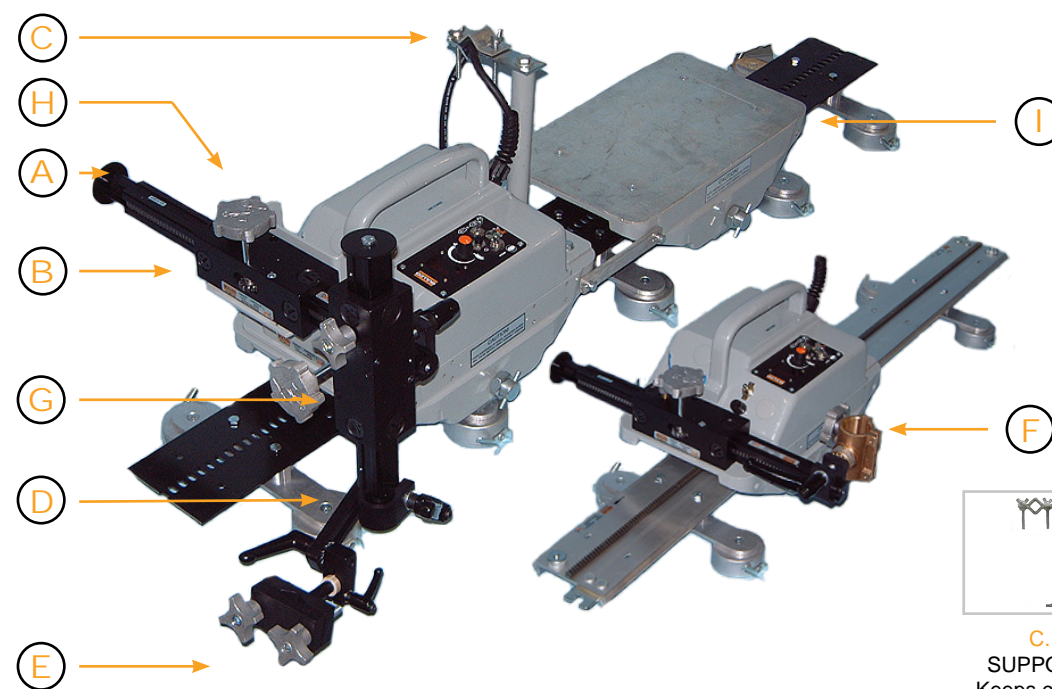

A. RACK ARM
Square with one end turned. Heavy duty & Extra heavy duty



B. RACK BOX
Available with standard or micro adjustment. Cross head & Arm Mount rack boxes also available



C. CABLE SUPPORT CLAMP
Keeps cables clear of work area



D. CLAMPS
Available as swivel or square.



E. SEMI-AUTOMATIC GUN HOLDERS
Suitable for most semi-automatic welding guns



F. BRONZE CUTTING TORCH HOLDERS
Accepts standard 1 3/8" (35 mm) cutting torch



G. 4 MOTION SEMI-AUTO GUN HOLDER
Mounts on the KAT® horizontal rack arm to provide 5" (127 mm) of vertical adjustment 360° torch rotation & two directional angle tilt



H. RISER BRACKET
To mount rack box higher than carriage when required



I. IDLER CARRIAGE
For conveying auxiliary welding and cutting equipment



RACK BOXES

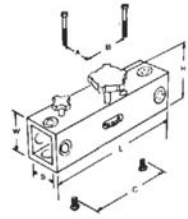

		H	W	L	S	A	B	C
HEAVY DUTY GK-171-650 GK-171-655*	In.	4.25	2.0625	6	1.125	1.625	2.625	-
	mm.	10.8	52.39	152.4	28.57	41.27	66.67	-
EXTRA HEAVY DUTY GK-190-650 GK-190-655*	In.	4.5	2.5	10	1.5	2	3.3	6
	mm.	114.3	63.5	254	38.1	50.8	83.82	152.4

***WITH MICRO FINE ADJUSTMENT GEAR BOX**

RACK BOXES FOR ARM MOUNTING

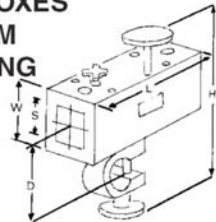

		H	W	L	S	D
HEAVY DUTY GK-171-685 GK-171-690*	In.	7	2.0625	6	1.125	1.75
	mm.	177.8	52.39	152.4	28.57	44.45
EXTRA HEAVY DUTY GK-190-685 GK-190-690*	In.	7.5	2.5	10	1.5	2.25
	mm.	190.5	63.5	254	38.1	57.15

***WITH MICRO FINE ADJUSTMENT GEAR BOX**

RACK ARMS



HEAVY DUTY RACK ARMS

1 1/8" (29mm) square rack arm and rack with one end turned to 1 1/8" (29mm) diameter

- GK-171-047-1** 12" (305mm) long
 - GK-171-047-2** 18" (457mm) long
 - GK-171-047-3** 24" (610mm) long
 - GK-171-047-4** 36" (914mm) long
- other lengths available on request

EXTRA HEAVY DUTY RACK ARMS

1 1/2" (38mm) square rack arm and rack with one end turned to 1 1/8" (29mm) diameter

- GK-190-047-2** 18" (457mm) long
 - GK-190-047-3** 24" (610mm) long
 - GK-190-047-4** 36" (914mm) long
- other lengths available on request

CLAMPS

Swivel Clamps

for mounting torch holders, rack boxes and other KAT@ accessories

		Dia.	W	D	A
HEAVY DUTY GK-166-183	In.	1.125	1.625	1.25	.775
	mm.	28.57	41.27	31.75	19.68

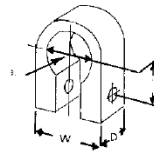

Square Clamps

for mounting welding guns, cutting torches and other KAT@ accessories

		Dia.	W	D	A
HEAVY DUTY GK-166-236	In.	1.125	1.625	1.125	1.0625
	mm.	28.57	41.27	28.57	27
EXTRA HEAVY DUTY GK-190-236	In.	1.5	2.125	1.25	1.437
	mm.	38	54	31.75	36.5

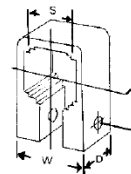

RACK BOX RISER BRACKET

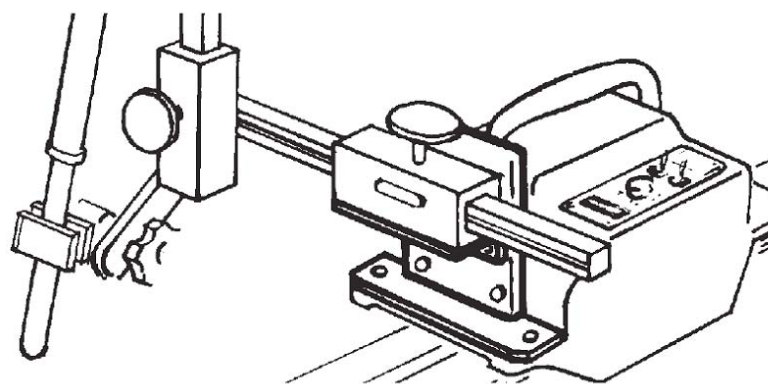

MODEL GK-190-066

For applications that require a mounting surface higher than the level provided with the rack box mounted directly on the front of the KAT@ Carriage. Height can be increased by 2, 4 or 6" (51, 102 or 152 mm).

TORCH HOLDERS AND ASSEMBLIES

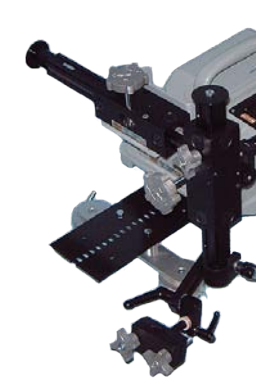

SEMI-AUTOMATIC 4 MOTION WELDING GUN HOLDER

MODEL GK-165-074-2

(complete unit)... For mounting on the KAT@ horizontal rack arm to provide 5" (127 mm) of vertical adjustment, 360° torch rotation and two directional tilt. Supplied complete with standard 1 1/8" (29 mm) I.D. swivel clamp* and insulated linkage for the gun holder which is suitable for most semi-automatic welding guns. Gun holder jaws are adjustable from 5/8" (16 mm) to 1 1/2" (38 mm) *Note: can be supplied with 1 1/8" (29 mm) or 1 1/2" (38 mm) square clamp.

SEMI-AUTOMATIC GUN HOLDER



MODEL GK-165-145 (complete unit)... Complete with standard 1 1/8" (29 mm) I.D. swivel clamp* and insulated linkage for the gun holder which is suitable for most semi-automatic welding guns. Gun holder jaws are adjustable from 5/8" (16 mm) to 1 1/2" (38 mm) *Note: can be supplied with 1 1/8" (29 mm) or 1 1/2" (38 mm) square clamp

IDLER CARRIAGES

GK-171-154

Provides an 8 3/4" x 14 7/8" platform on which a variety of welding/cutting equipment can be mounted and towed individually or in tandem along straight or formed sections of KAT@ Track by the Gullco KAT@ Travel Carriage. Self aligning retractable wheels enable easy mounting at any point along the track. Load capacity is 100lbs.



REMOTE CONTROL PENDANT

Supplied with 10 ft. (304.8 cm) cable providing control of numerous KAT@ functions.



STANDARD CUTTING TORCH HOLDER

GK-165-068B

Accepts standard 1 3/8" (35 mm) cutting torches with 32 pitch rack. Supplied with calibrated angle of tilt scale and 1 1/8" (29 mm) or 1 1/2" (38 mm) square clamp.



CABLE SUPPORT CLAMP

GK-181-027

Swivel clamp assembly is readily mounted on the front or back of the KAT@ Travel Carriage to keep cables clear of the work area. Clamp can be adjusted to provide approximately 1 3/4" diameter holding opening



SEAM TRACKER SYSTEM



...high precision tracking system that maintain the torch in optimum operating position regardless of variations in the weld seam...providing improved quality and efficiency in a wide variety of welding operations.