



“MOGGY” PORTABLE FRICTION DRIVE CARRIAGE



MODELS:

GM-03-050 - GM-03-100
GM-03-250 - GM-03-200

OPERATING INSTRUCTIONS

Website: www.gullco.com

Distributed by:

GULLCO INTERNATIONAL LIMITED – CANADA

Phone: 905-953-4140 Fax: 905-953-4138 e-mail: sales@gullco.com

GULLCO INTERNATIONAL INC. – U.S.A.

Phone: 440-439-8333 Fax: 440-439-3634 e-mail: ussales@gullco.com

GULLCO INTERNATIONAL [U.K.] LIMITED - EUROPE

Phone: +44 1257-253579 Fax: +44 1257-254629 e-mail: sales@gullco.co.uk

GULLCO INTERNATIONAL PTY LIMITED - AUSTRALIA

Phone: 61 (0) 7 3348-5515 Fax: 61 (0) 7 3348-5510 e-mail: ausales@gullco.com

GULLCO INTERNATIONAL LIMITED – INDIA

Phone: 91-20-65260382 Fax: 91-20-26836656 e-mail: India.io@gullco.com

GULLCO INTERNATIONAL SHANGHAI – LIMITED

Phone: +8621-50460341 Fax: +8621-50463554 e-mail: c.zhang@gullco.com

SAFETY INSTRUCTIONS

Although the “MOGGY” carriage is manufactured for safe and dependable operation, it is impossible to anticipate those combinations of circumstances, which could result in an accident. An operator of this equipment is cautioned to always practice "**Safety First**" during each phase of operation, setup and maintenance.

Read and understand the whole Operation Manual (including the additional Technical Manual complete with the supplementary GSP Control Manual, “GD-031”) before operating or performing service of this equipment. Become familiar with the machines operation, applications and limitations. Keep the operation manual in a clean and readily available location.

This equipment is normally used to automate / semi-automate welding or cutting processes. These processes usually have any combination of the following; bright and hot arcs, flying sparks, fumes, ultraviolet and infrared radiated energy, hot work-pieces, compressed gases, etc.. The onus is on the operator of this equipment to know, understand and follow all the safety precautions associated with the process being used.

A careless operator invites troubles, and failure to follow safety practices may cause serious injury or even death. Important safety precautions are given in the following:

Electrical Shock Prevention

- Do not use this equipment in damp or wet locations.
- Do not expose this equipment to rain.
- Never carry this equipment by the cables or pull the cables to disconnect from the receptacle.
- Keep all cables from heat, oil and sharp edges.
- Inspect all cables periodically and replace if damaged.
- Inspect the secureness of all cables periodically and repair if loose.
- Disconnect the power cord when not in use.
- Disconnect the power cord **positively** to prevent electrical shock before repair and service of the equipment.

Bodily Injury Prevention

- Do not wear loose clothing, jewellery and loose, long hair, which may get caught into automatic systems or moving parts.
- Keep lifting handle dry, clean and free from oil and grease.
- Do not operate this equipment if ill or drowsy from medication or fatigue.
- Always keep the “MOGGY” clean and in good working order.
- Report any unsafe condition for immediate correction.

ALL THE SAFE PRACTICES AND PRECAUTIONS MAY NOT BE GIVEN IN WRITING. SOME ARE BASED ON COMMON SENSE, BUT OTHERS MAY REQUIRE TECHNICAL BACKGROUND TO EXPLAIN.

SAFETY INSTRUCTIONS

The following cautionary/warning label is attached to each “MOGGY” carriage:-

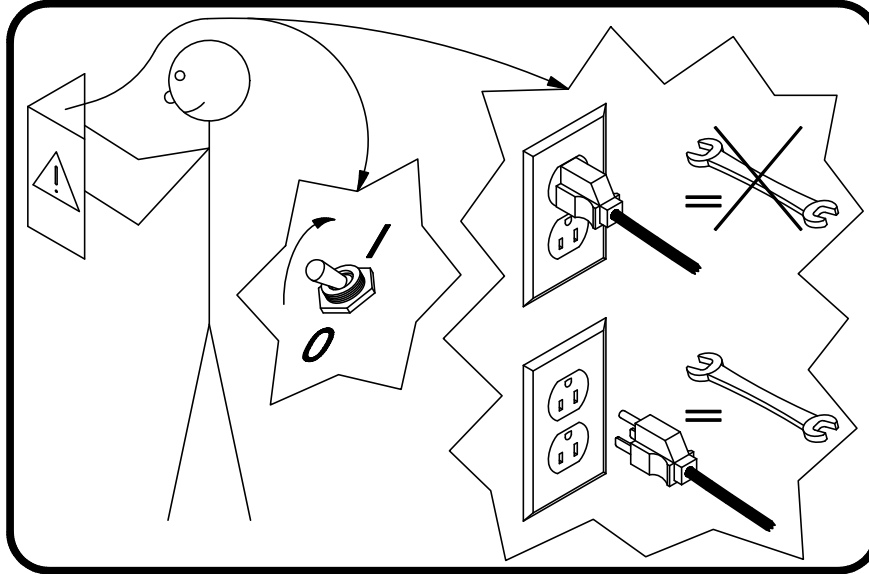

The above label pictorially represents the following:

“Warning:-

*Read the manual before turning the unit on and before performing service.
Also, positively disconnect the unit from all power supplies before servicing!”*

IMPORTANT

READ THIS BEFORE OPERATING THE “MOGGY” CARRIAGE

Ensure that an adequate and well-maintained weld return path is provided with good electrical contact. Failure to do so may result in the welding current passing through the carriage and damaging the wiring and electrical components.

Important information regarding safety and operation of the “GSP” motor control used in the “MOGGY” carriage is contained in a supplemental manual attached at the end of the Technical Manual. It is equally important to read, understand and apply the information contained within the manual. The manual (GD-031) has a title “Technical Information For The Gullco “GSP” Micro-Processor Based, 24 Volt DC Motor Control”, and it’s pages are numbered with a prefix of “T-“.

Warranty will be void if genuine Gullco replacement parts are not used.



“MOGGY” PORTABLE FRICTION DRIVE TRAVEL CARRIAGE

This manual covers the operating instructions of the following “MOGGY” travel carriages;- GM-03-050, GM-03-100, GM-03-200 and GM-03-250.

GENERAL DESCRIPTION

The Gullco “MOGGY” is a portable, friction drive travel carriage, designed with multiple functionality in mind. It is an electrically powered self propelled carriage that travels in forward and reverse directions at precisely controlled speeds. It consists of a 24 VDC permanent magnet gear motor which engages with the drive axle through a pair of bevel gears. The drive and driven axles are connected through a toothed timing belt arrangement which allows both axles to impart a tractive effort through the four rubber tired, friction drive wheels. Fine adjustment horizontal and vertical positioning slides as well as a fully adjustable gun/torch holder positioning assembly, are used to attach the welding gun(s) or cutting torch(es), to the “MOGGY” carriage. Adjustable guide roller assemblies enable the “MOGGY” carriage to maintain a set distance from a vertical member (usually the vertical member of a fillet joint). The unit is equipped with a raised carrying handle for lifting, as well as for hanging when in storage. Safety is greatly enhanced by the use of Gullco’s low voltage (24 VDC), highly advanced control and power supply system that is available in three line voltage inputs...42, 115 and 230 VAC, single phase, 50/60 Hz., or alternately, any unregulated 24 V power supply at 30 watts of power. The microprocessor motor control offers operator interface of forward, reverse, infinitely variable speed, weld enable and disable functions and, depending on the model, various welding/stitch welding parameters. An L.E.D. display indicates different modes and status of operation as well as showing the travel speed in either inches per minute or centimetres per minute. An end of travel limit switch and actuating rod is used to stop the “MOGGY” and welding/cutting cycle when activated. The drive wheels are constructed from silicone rubber with an operating temperature range of -65°F to 450°F [-54°C to 232°C].

INTENDED / FORESEEN USAGE

The Gullco “MOGGY” is intended to automate and improve the quality of welding and cutting operations by carrying the welding gun(s) or cutting torch(es), at precisely controlled speeds, along the path of the joint as well as providing the interface between the welding/cutting motion and the arc start and stop signal(s). The “MOGGY” is normally guided by adjustable guide wheels which are set to always drive the carriage slightly into the vertical member (usually either the vertical member of a fillet joint or a template/fence placed parallel to the joint). Industry standard 6” V-groove track may also be used to guide the path of the “MOGGY” carriage. The “MOGGY” carriage is flexible enough to allow it to be easily configured for horizontal lap, butt and fillet weld joints as well as a variety of cutting processes. All of the available models provide continuous mode welding/cutting and the GM-03-100 and GM-03-200 models also offer accurate distance stitch weld functionality, regardless of travel speed adjustment. Using the Gullco “MOGGY” travel carriage system will add accuracy and uniformity to welding/cutting operations while increasing productivity. Typical applications include shipbuilding, offshore construction, steel fabrication industries, etc...

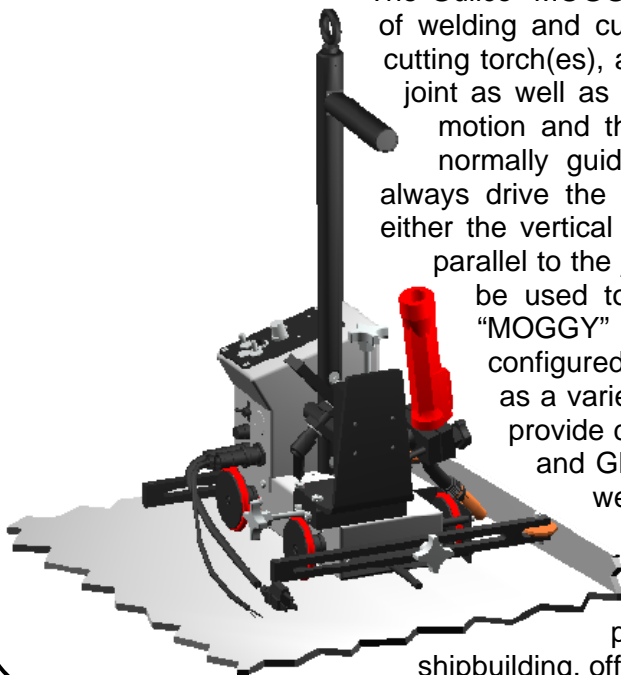

SETUP

Once the “MOGGY” has been assembled and installed, as detailed in the Technical Manual, adjust the vertical and horizontal slides so that they are in the middle of their strokes. Insert the welding gun(s) or cutting torch(es), into the gun holder(s). Position the gun(s) or torch(es) to the desired operating position(s). Then adjust the two guide roller assemblies so that when both guide wheels are running along the vertical member of the work-piece to be welded (or a template, guide or fence if no vertical member is available), the leading guide wheel is marginally less extended than the trailing guide wheel. On a straight work-piece, the optimum amount of difference is approximately 1” [25.4mm]. This places the “MOGGY” carriage at approximately 5° off parallel to the work-piece, ensuring that as the “MOGGY” travels along, it is always driving in towards the vertical guide. This ensures that the gun/torch to joint distance is always maintained. Fine positioning of the gun/torch to joint may then be performed with the horizontal and vertical slides.¹

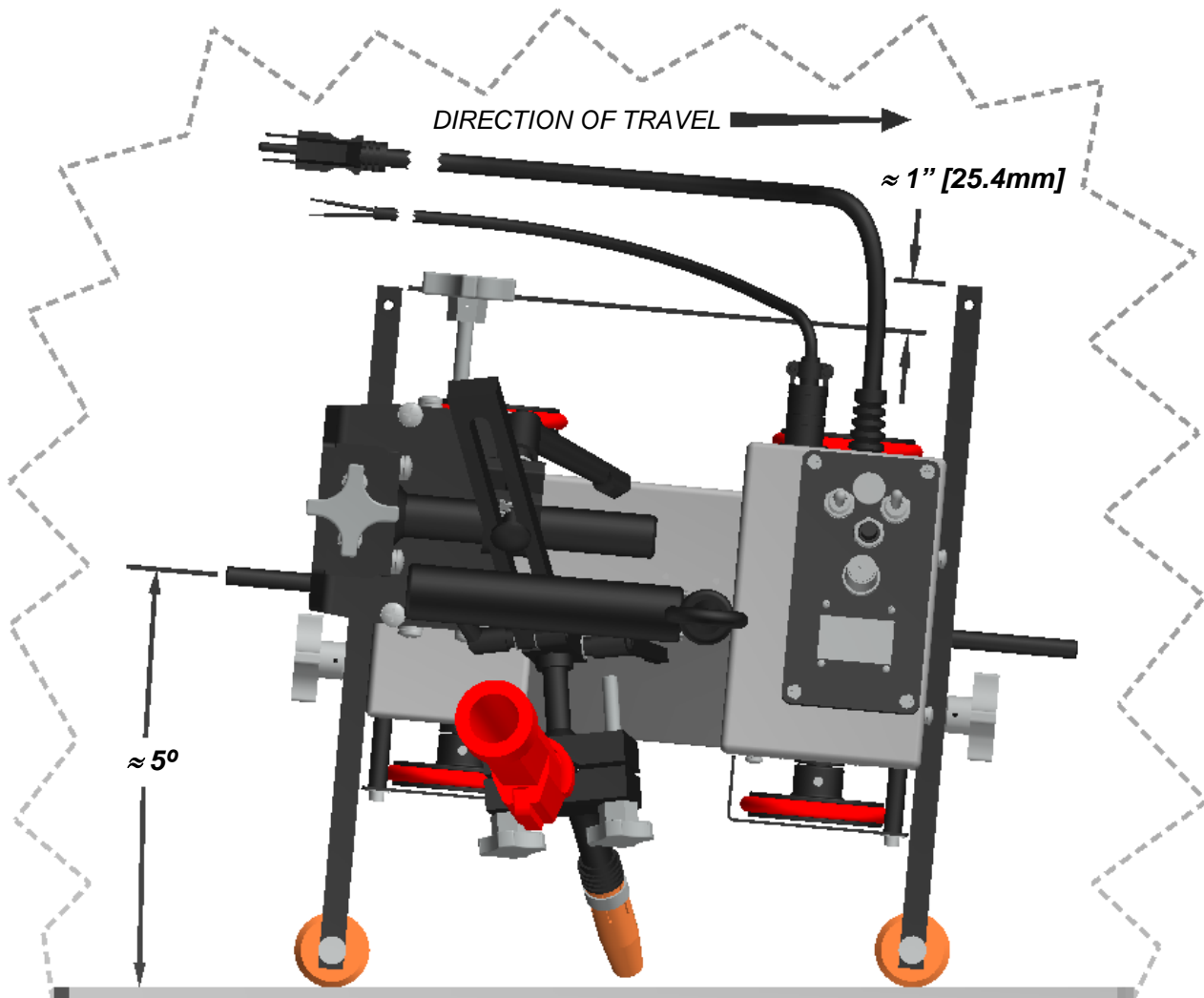

¹ The plural references above relate to the GM-03-200 & GM-03-250 twin gun models

Other typical set-ups are shown below:

**APPLICATION OF A “MOGGY”
PERFORMING A BUTT WELD
USING A GUIDE FENCE**

A TEMPLATE, GUIDE OR FENCE IS POSITIONED PARALLEL FROM THE JOINT AND SECURED FOR THE “MOGGY” TO DRIVE ALONG

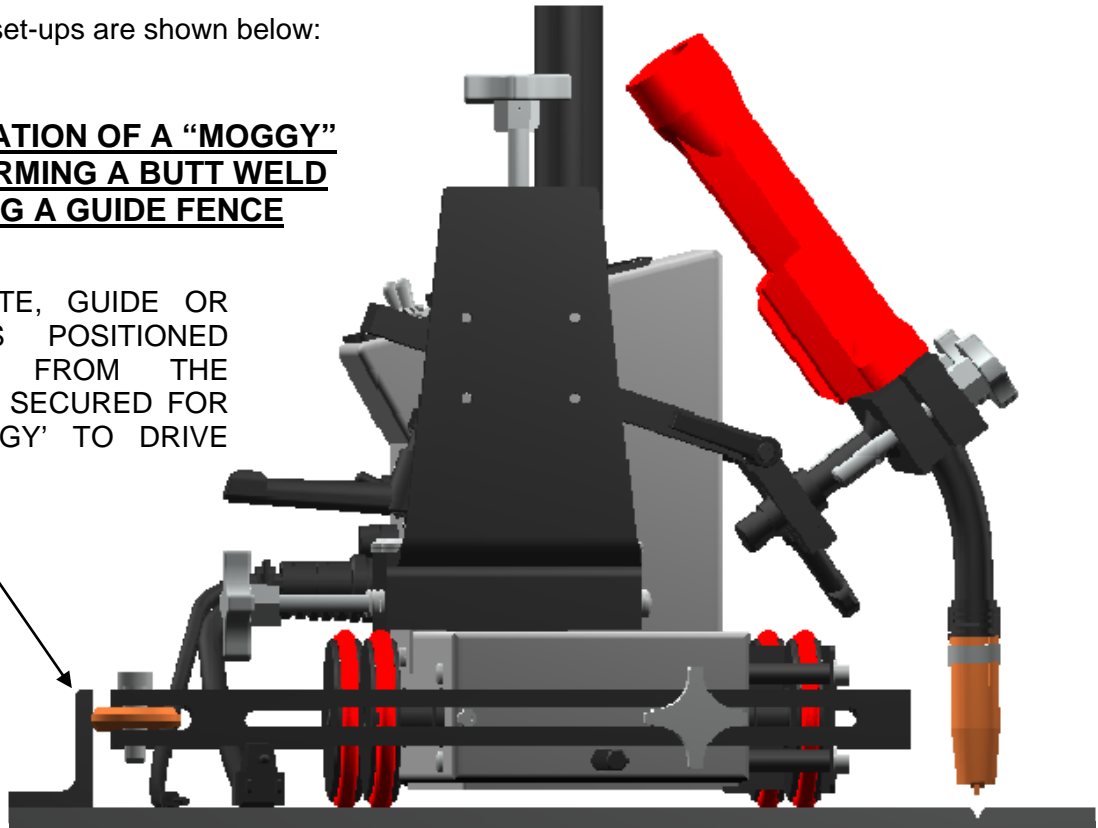

**APPLICATION OF A
“MOGGY” PERFORMING A
LAP WELD USING
INDUSTRY STANDARD
TRACK**

DRIVE WHEELS REVERSED TO PROVIDE 6" CENTRES

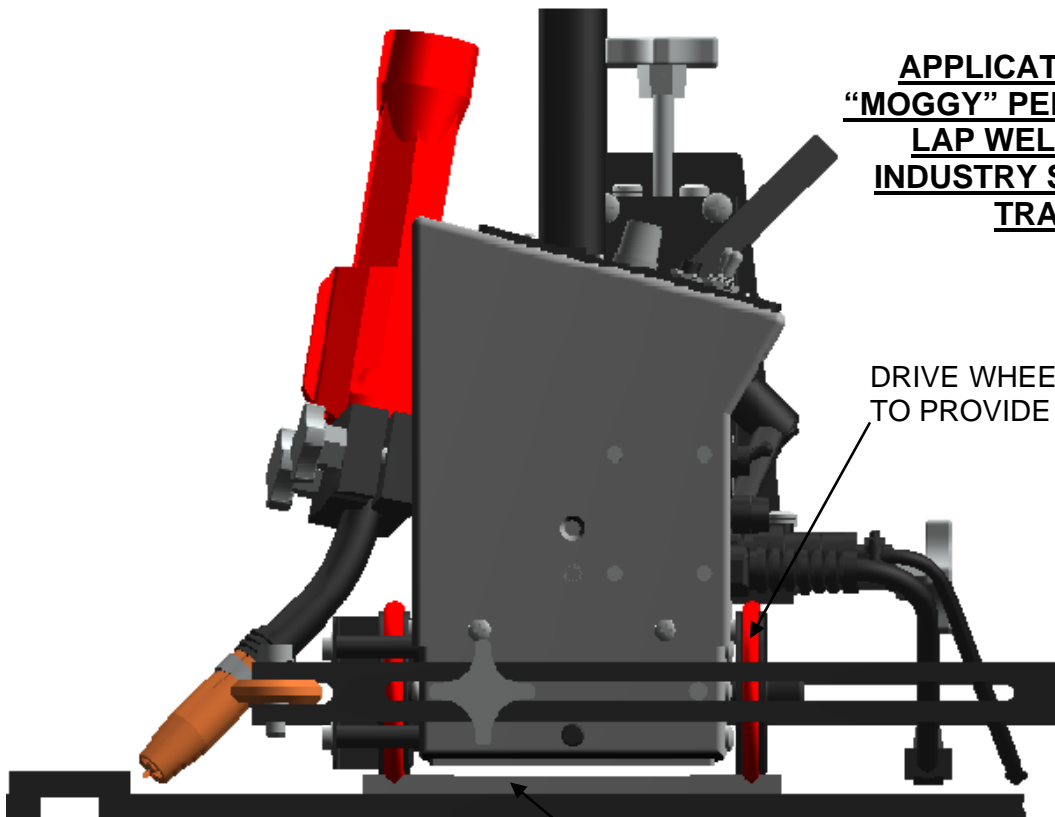

6" [152.4mm] "V"-GROOVE TRACK
RUNNING PARALLEL TO THE JOINT

OPERATION

The GM-03 series of “MOGGY” carriages use Gullco’s sophisticated “GSP” microprocessor motor controls.

- The GM-03-050 and GM-03-250 models use GSP-2000-9 motor controls
- The GM-03-100 and GM-03-200 models use GSP-2010-10 motor controls.

GSP Control Overview

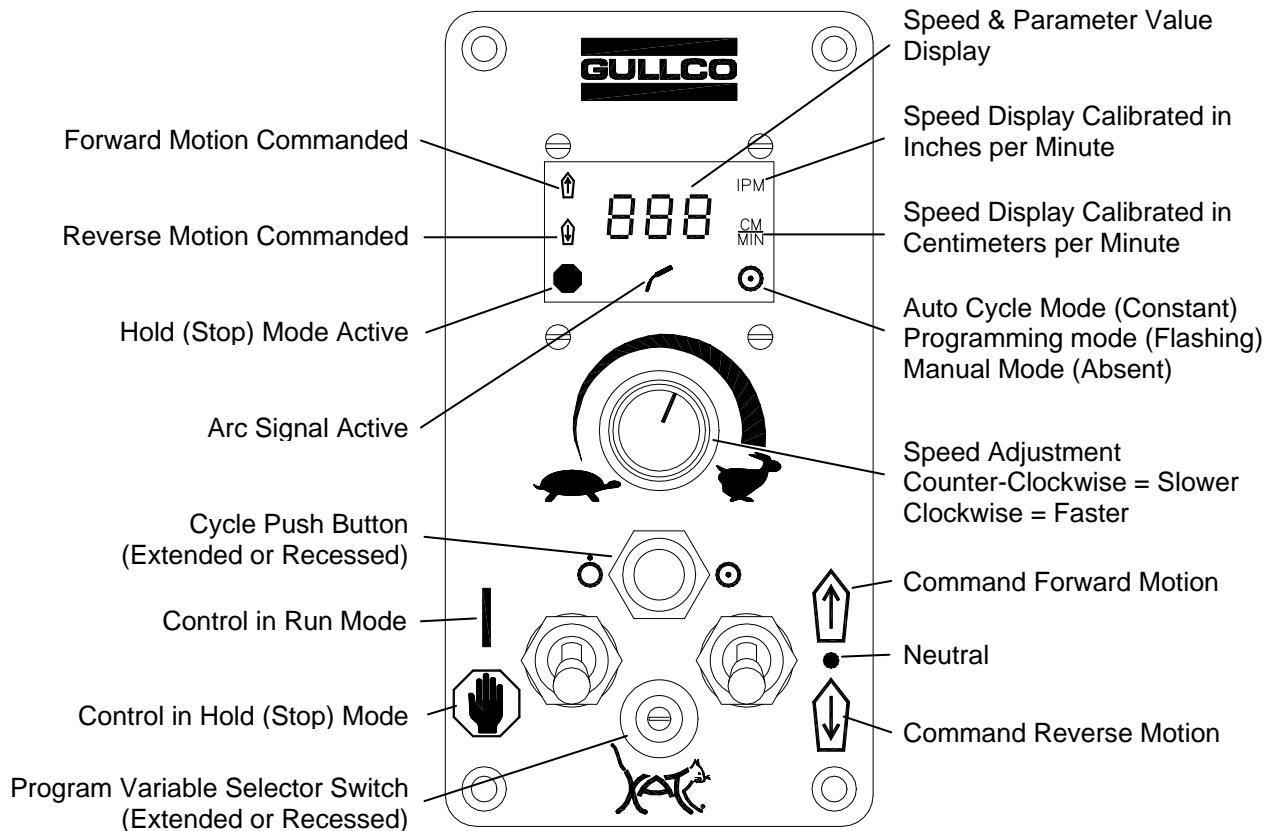

The following provides a brief description of the GSP controls (refer to the above sketch):

The Cycle Push Button – is a momentary device, which when pressed for one second while the Run/Stop switch is in the Stop position, will toggle between Manual Mode (Hnd) and Automatic Mode (Aut). When in Automatic Mode the Auto Cycle Mode LED will be illuminated. *The Cycle Push Button is also used to increment/decrement the values/settings of the program variables (refer to the section “Programming The Automatic Cycle Parameters/Variables” later in this manual for further details of this function).*

The Run/Stop Switch – is used to start and stop the “MOGGY” carriage in either Manual Mode or Automatic Mode. The Hold (Stop) position is also used to reset most error codes once they have been rectified.

The Forward/Neutral/Reverse Switch – is used to select the travel direction desired in both Manual Mode and Automatic Mode. *The Forward position is used to select increment, while the reverse position is used to select decrement as the method of changing the values/settings of the program variables (refer to the section “Programming The Automatic Cycle Parameters/Variables” later in this manual for further details of this function).*

The Speed Adjustment Knob - is used to increase (clockwise) or decrease (counter-clockwise) the travel speed of the carriage, both in Manual Mode and Automatic Mode. The carriage will travel at full speed during the no-weld part of a stitch cycle. The speed display will show the set speed when the Run/Stop switch is in the Stop position and the Forward/Neutral/Reverse switch is in the Neutral position.

The Program Variable Selector Switch – is a ten position rotary switch, used to set some of the values and settings which apply to the Automatic Cycle. This selector switch is located under a hole plug in the face plate on the GM-03-050 and GM-03-250 models, and is an extended rotary switch on the GM-03-100 and GM-03-200 models. *Refer to the section “Programming The Automatic Cycle Parameters/Variables” later in this manual for further details of this selector switch.*

Please refer to the Technical Manual and its supplemental manual (GD-031) “Technical Information For The Gullco “GSP” Micro-Processor Based, 24 Volt DC Motor Control” (the pages are numbered with a prefix of “T-“), for additional, more comprehensive details than those provided in the following overview.

Manual Operation

To toggle between automatic mode (Aut) and manual mode (Hnd), place the Run/Stop switch in the Stop position and press and hold the Cycle Push Button until the desired mode is displayed (Aut or Hnd).

In manual mode (Hnd) the Auto Cycle Mode L.E.D. located in the lower right hand corner of the display will be extinguished.

Manual mode only permits manual motion of the “MOGGY” carriage (no Arc Signal Relay activation). The Forward/Neutral/Reverse switch selects which direction the “MOGGY” will travel. The Speed Adjustment knob sets the linear travel speed. When the Run/Stop switch is placed in the Run position, the “MOGGY” carriage will travel in the direction and speed set by the Forward/Neutral/Reverse switch and the Speed Adjustment knob. Travel motion will cease if; the Run/Stop switch is placed in the Stop position; the Forward/Neutral/Reverse switch is placed in the Neutral position; the speed is set to zero; or the travel limit switch is activated.

Automatic Operation

To toggle between automatic mode (Aut) and manual mode (Hnd), place the Run/Stop switch in the Stop position and press and hold the Cycle Push Button until the desired mode is displayed (Aut or Hnd).

When the control is in automatic mode (Aut) the Auto Cycle Mode L.E.D. located in the lower right hand corner of the display will be constantly illuminated.

In automatic mode (Aut), the activation and subsequent procedure of an automatic cycle are described below:

1. The automatic cycle is initiated by placing the Forward/Neutral/Reverse switch in either the Forward or Reverse position and the Run/Stop switch in the Run position. The cycle then proceeds to section 2.
2. The Arc Signal Relay(s) (GK-191-P-071) is energized and the Travel Motion Delay is initiated. The cycle then proceeds to section 3.
3. Upon completion of the Travel Motion Delay, the “MOGGY” carriage starts to travel in the direction set by the Forward/Neutral/Reverse switch, at the speed set by the potentiometer.
 - a. If the “MOGGY” is a GM-03-050, or a GM-03-250 the cycle then proceeds to section 9.
 - b. If the “MOGGY” is a GM-03-100, or a GM-03-200 and the Stitch Weld Parameter (P.4) is set to OFF, the cycle then proceeds to section 9.
 - c. If the “MOGGY” is a GM-03-100, or a GM-03-200 and there is a numeric value entered in the Stitch Weld Parameter (P.4), the cycle then proceeds to section 4.
4. When the carriage has travelled the distance equal to that set in the Stitch Weld Parameter (P.4), the weld travel will cease and the Crater Fill Delay timing cycle will initiate. The cycle will then proceed as per section 5.
5. Upon completion of the Crater Fill Delay (maintaining the Arc Signal after the weld motion has ceased, thereby filling the weld crater) the Arc Signal Relay is de-energized and the Post Weld Delay timing cycle is initiated. The cycle then proceeds to section 6.
6. Upon completion of the Post Weld Delay (keeping the carriage stationary to allow time for any burn-back or post flow welding functions), the “MOGGY” carriage travels at full speed in the same direction, until the carriage has travelled the distance equal to that set in the No-Weld Spacing parameter (P.5), at which point the travel ceases immediately. A set timing delay of 0.7 seconds elapses, allowing the carriage to come to a complete stop, before the cycle continues to section 7.
7. The Arc Signal Relay is re-energized and the Travel Motion Delay is initiated. The cycle then proceeds to section 8.
8. Upon completion of the Travel Motion Delay, the “MOGGY” carriage starts to travel in the direction set by the Forward/Neutral/Reverse at the speed set by the potentiometer. The cycle continues as described between section 4 and 8 until an event described in section 9 occurs.
9. When the Run/Stop switch is placed in the Stop position, or the Forward/Neutral/Reverse switch is placed in the Neutral position, or if the limit switch is activated, then the travel motion will cease, and;
 - a. If the Arc Signal was not energized, the cycle is now completed and “End” is displayed.
 - b. If the Arc Signal was energized, the Crater Fill Delay will commence. Upon completion of the Crater Fill Delay, the Arc Signal will de-energize and the cycle is now completed and “End” is displayed.

Programming The Automatic Cycle Parameters/Variables

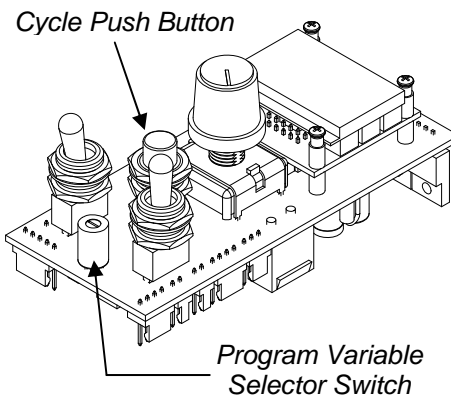

The Program Variable Selector Switch is used to select the different programmable parameters that allow the operator to change their values and settings and so define how the automatic cycle will function. The Program Variable Selector Switch is located between and below the Run/Stop switch and the Forward/Neutral/Reverse switch of the GSP control. The Program Variable Selector Switch on the GM-03-100 & GM-03-200 models is extended through the faceplate for easy access. The recessed selector switch on the GM-03-050 & GM-03-250 models requires the removal of a hole plug in the faceplate for access and a small flat-bladed screwdriver for adjustment.

Zero (0) (top dead centre) is the normal operating location for the switch. When in any position other than zero (0) the control is in programming mode, the round, Auto Cycle Mode L.E.D. in the bottom right hand corner of the display will flash and the motor control will not allow normal operation.

To make changes to the program variables, remove the hole plug on the front face which covers the recessed Program Variable Selector switch (where applicable). With the power turned on and the Run/Stop switch in the Stop position, rotate the Program Variable Selector switch to the variable (parameter) to be altered (the Auto Cycle Mode L.E.D. will flash on and off). The number of the variable parameter will be displayed when the Forward/Neutral/Reverse switch is in the Neutral position. I.e. "P. 1", "P. 2", "P. 3", etc. To see the current value/setting of the variable, place the Forward/Neutral/Reverse switch in either the Forward or Reverse position. To increment (increase) the value/setting, place the Forward/Neutral/Reverse switch in the Forward position and press the Cycle Push Button. To decrement (reduce) the value/setting, place the Forward/Neutral/Reverse switch in the Reverse position and press the Cycle Push Button. Pressing the Cycle Push Button briefly will increment/decrement the value/setting by one, whereas keeping the Cycle Push Button depressed will scroll through the values/settings until released. The speed display and or the individual L.E.D.'s will indicate the chosen value/setting. When all of the program variables are set, place the Program Variable Selector switch back to the zero position (the Auto Cycle Mode L.E.D. will stop flashing) and re-insert the hole-plug (where applicable).

The values/settings of the variables are stored on the product/application specific micro-processor chip. If the chip is replaced, the values/settings of the variables will need to be re-entered.

Description of Programmable Parameters/Variables

All Models

The following describes the Program Variable Selector Switch settings for the GSP motor control using Gullco's GSP-2004-9 micro-processor chip (GM-03-050 and GM-03-250 models), or GSP-2004-10 (GM-03-100 and GM-03-200 models), as rotated clockwise from zero (0) top dead centre.

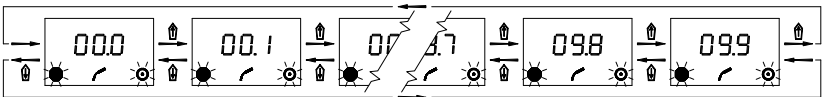
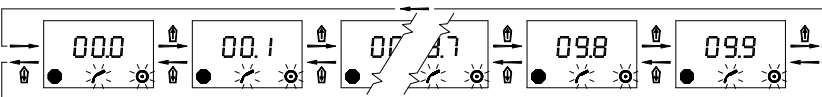
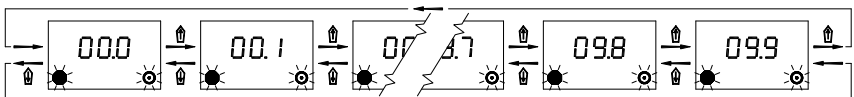
Position	Details:
0	Normal Operating Position - The control needs to be in this position to allow normal operation of the unit (top-dead-centre).
P. 1	<p>Travel Motion Delay - Sets a delay after the activation of the Arc Signal Relay, prior to starting the weld travel, to allow for such things as shielding gas preflow and to allow the arc to establish before starting the welding/cutting motion. The variable value range is from 00.0 to 09.9 seconds, in increments of 00.1 seconds.</p> 
P. 2	<p>Crater Fill Delay - Sets a delay after the cessation of welding/cutting travel prior to de-energizing the Arc Signal Relay, allowing the welding/cutting signal to remain active after the motion has stopped. The variable value range is from 00.0 to 09.9 seconds, in increments of 00.1 seconds.</p> 
P. 3	<p>GM-03-050 & GM-03-250 - Not Applicable. GM-03-100 & GM-03-200 - Post Weld Delay - Sets a delay after the Crater Fill Delay (above) prior to allowing the full-speed, no-weld motion to start. This is to allow the equipment to remain stationary over the end of the weld/cut for such things as burnback or postflow to occur. The variable value range is from 00.0 to 09.9 seconds, in increments of 00.1 seconds.</p> 

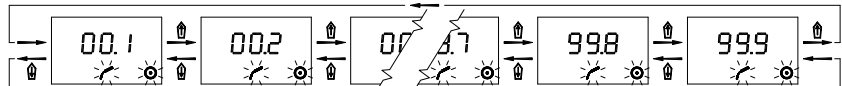
P. 4	<p>GM-03-050 & GM-03-250 - Not Available. GM-03-100 & GM-03-200 – Stitch Weld - Enables/disables stitch welding and specifies length of each weld stitch. When OFF is selected the weld will be continuous. A numerical value specifies the distance in inches or cm (dependant upon the unit calibration of the control) that the carriage will travel during a stitch weld.</p> 
P. 5	<p>GM-03-050 & GM-03-250 - Not Available. GM-03-100 & GM-03-200 – No-Weld Spacing - Specifies the distance in inches or cm (dependant upon the unit calibration of the control) that the carriage will travel between stitch welds. If the Stitch Weld parameter is set to “Off”, then this parameter is disabled (forced to Off) and the display variable will show “- - -”.</p> 

Factory Settings:

The following table shows the settings/values of the Programmable Parameter/Variables as supplied from the factory:

Switch Position	Parameter	GM-03-050 & GM-03-250 (GSP-2004-9) Value	GM-03-100 & GM-03-200 (GSP-2004-10) Value
P. 1	Travel Motion Delay	00.3 (seconds)	00.3 (seconds)
P. 2	Crater Fill Delay	00.5 (seconds)	00.5 (seconds)
P. 3	Post Weld Delay	- - -	01.0 (seconds)
P. 4	Stitch Weld Selection	- - -	Off
P. 5	No-Weld Spacing	- - -	- - -
P. 6	Not Applicable	- - -	- - -
P. 7	Not Applicable	- - -	- - -
P. 8	Not Applicable	- - -	- - -
P. 9	Not Applicable	- - -	- - -

One of the following labels is applied adjacent to the GSP control as a pictorial guide:

GM-03-050 & GM-03-250 Models

GM-03-100 & GM-03-200 Models

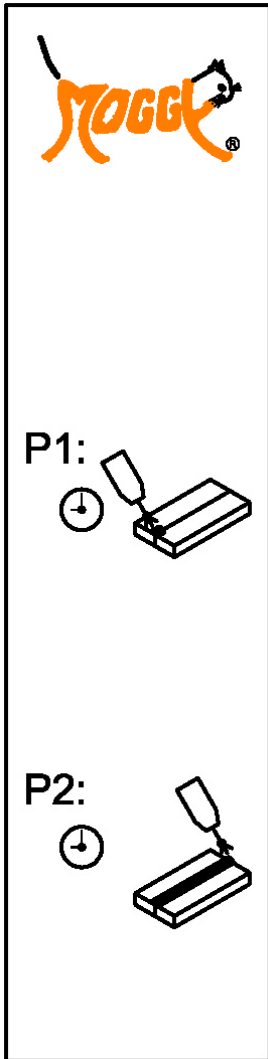

P. 1 - Travel Motion Delay

P. 2 - Crater Fill Delay

P. 3 - Post Weld Delay

P. 4 - Stitch Weld Selection

P. 5 - No-Weld Spacing

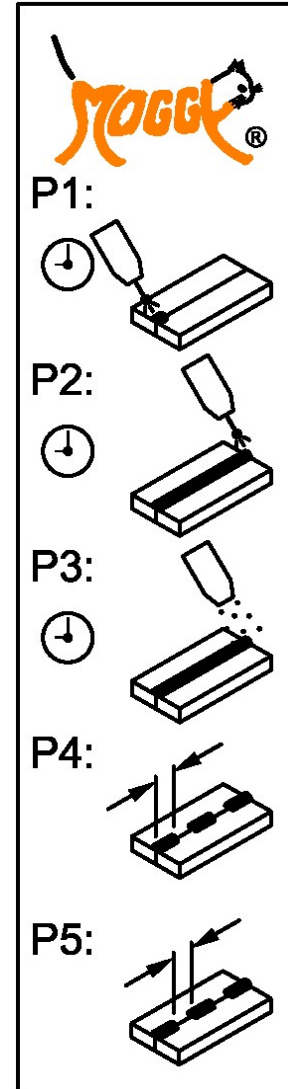

The standard equipment and functionality as described in this manual is suitable for a large percentage of simple welding and cutting procedures, however, Gullco has many different product/application modules, attachments and programs to accommodate more complex applications requiring features above those provided here. Please consult your local Gullco dealer to discuss your specific application.

OPTIONAL ACCESSORIES

GK-194-O-330 RADIAL OSCILLATOR PACKAGE FOR “MOGGY”

The radial oscillator package for “MOGGY” travel carriages, provides a motorized mechanism to oscillate (weave) the welding gun across the joint, while the “MOGGY” provides the weld travel motion. The radial oscillator head replaces the standard gun holder assembly and is mounted to the 7/8” Ø spigot protruding from the adjustable slides. The package comes complete with adjustable mounting brackets, radial oscillator head, extended length guide arms, control cable and control pendant available in either 42, 115 or 230 VAC, single phase, 50/60 Hz., 30 watts. Refer to the Technical Manual for component details.

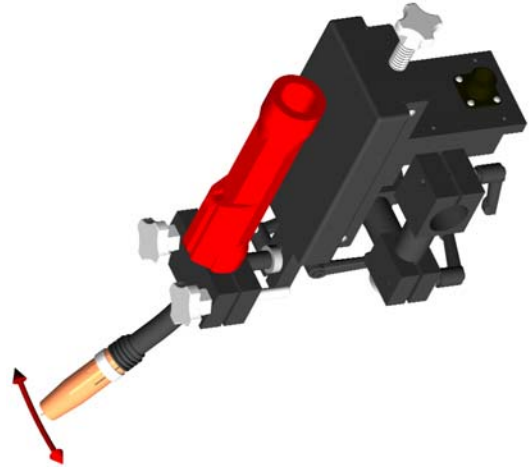

GM-01-065 & GM-01-065-M “MOGGY” CUTTING TORCH HOLDER ASSEMBLIES

By replacing the standard gun holder assembly with a “MOGGY” cutting torch holder assembly, the “MOGGY” carriage is able to position and clamp any standard 1-3/8” [35mm] diameter, 32 pitch rack (using a GM-01-065), or a 1-1/4” [32mm] diameter, 32 pitch rack (using a GM-01-065-M), machine type cutting torch (or TIG torch). The “MOGGY” cutting torch holder assembly provides ease of positioning of the cutting torch through easy to use adjustable hand levers and knobs (no tools necessary), and various linear and rotational adjustments. The torch holder clamp is equipped with a knob and pinion to provide torch height adjustment in addition to the horizontal and vertical slides of the “MOGGY”. Refer to the Technical Manual for component details.

GM-01-070 DUAL GUN HOLDER ASSEMBLY

This conversion kit allows a GM-03-050 to be converted to a GM-03-250 or a GM-03-100 to be converted to a GM-03-200. By attaching a dual gun holder assembly to a “MOGGY”, you are able to independently position two welding guns from the “MOGGY” and activate two wire feed signals simultaneously. Refer to the Technical Manual for component details.

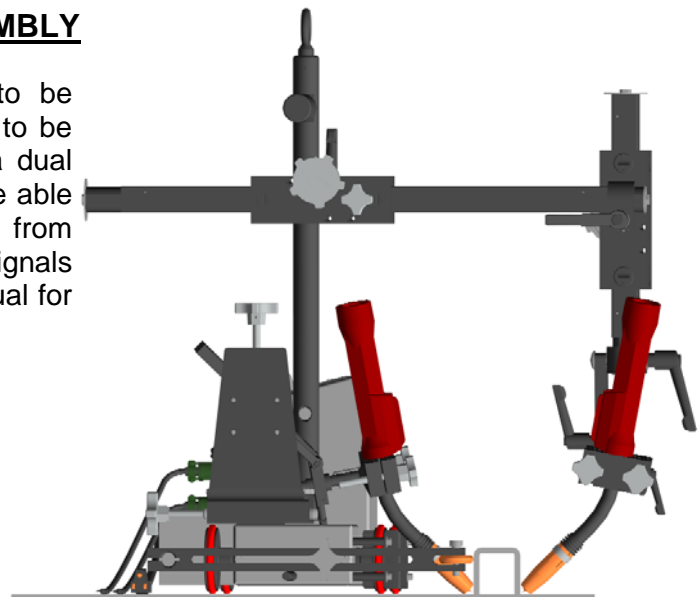

Optional Accessories Continued...

GM-01-091 INNER RADIUS GUIDE ARM ASSEMBLY

This attachment kit allows the leading guide roller to be moved further forward of the “MOGGY” carriage than normal, allowing the “MOGGY” carriage to track along the inside face of small radii applications. Refer to the Technical Manual for component details.

GM-03-059 & GM-03-060 ADJUSTABLE GUIDE WHEEL ASSEMBLIES

These versatile guide wheel assemblies allow extra height and angular adjustment to facilitate the tracking of vertical faces that would otherwise be out of reach of the standard, fixed height, guide wheels supplied with the “MOGGY”. These adjustable guide wheel assemblies readily attach to the end of standard guide arms supplied on “MOGGY’s” with serial numbers greater than 11466. (For “MOGGY’s” with serial numbers prior to 11466, the GM-03-028 Guide Arms will need to be ordered separately). The GM-03-059 is recommended for most applications requiring adjustable guide wheels, as the guide roller has a larger, more durable face. The GM-03-060 is recommended for applications such as small lap joints, as it has a smaller face and finer taper. The sketches below show two examples using these adjustable guide wheel assemblies. Refer to the Technical Manual for component details.

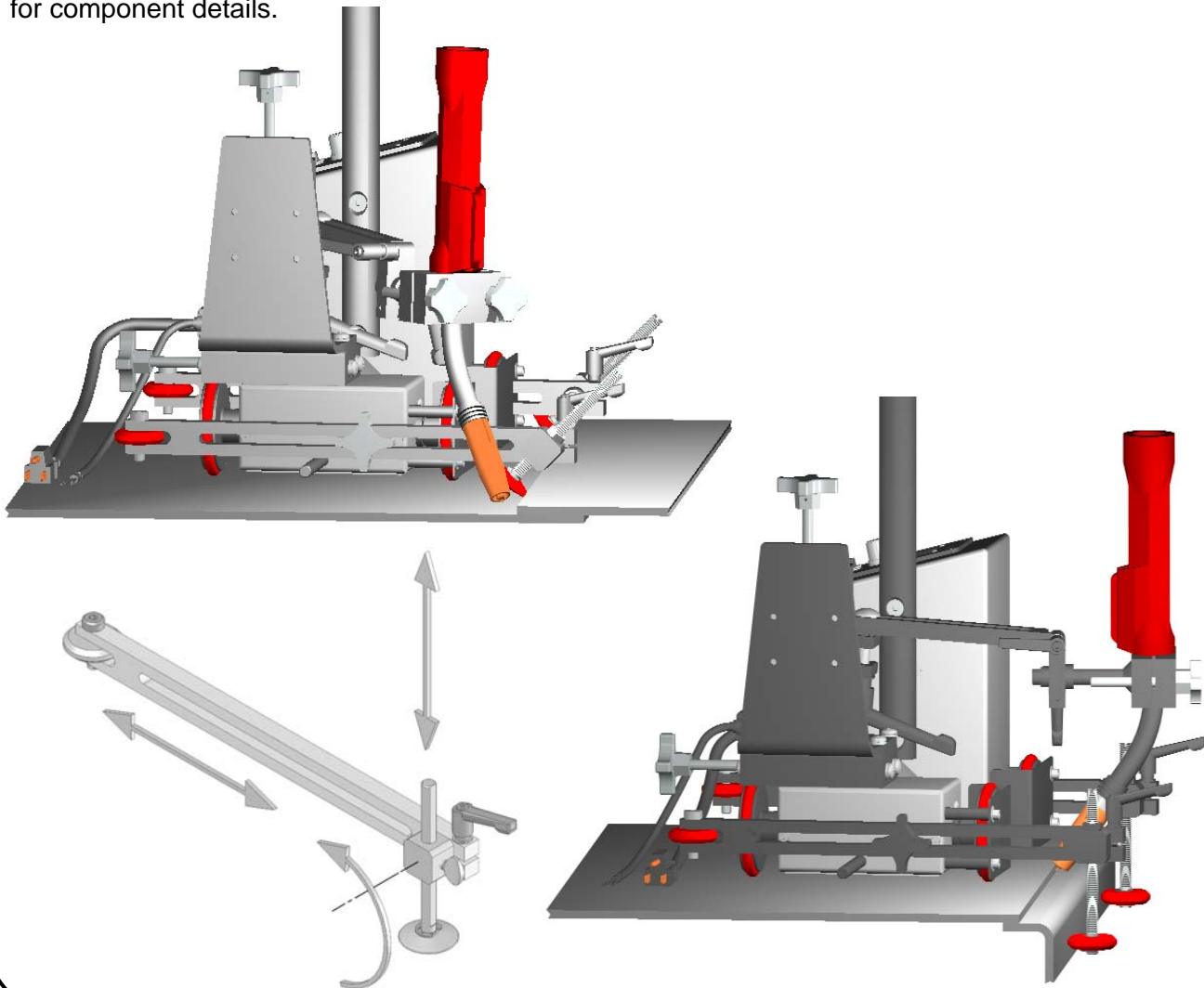

Optional Accessories Continued...

GM-186-320 360° TORCH ADJUSTMENT ASSEMBLY

This rotary adjusting gun clamp assembly easily attaches to the end of the existing gun holder Adjustable Link Arm supplied with the Moggy, and provides precise angular positioning adjustment of the welding gun laterally across the joint to be welded. Adjustments are made by turning a hand knob (one on each side of the unit for easy access) to obtain the desired angular tilt. A thumb screw is provided to lock the angular position when required.

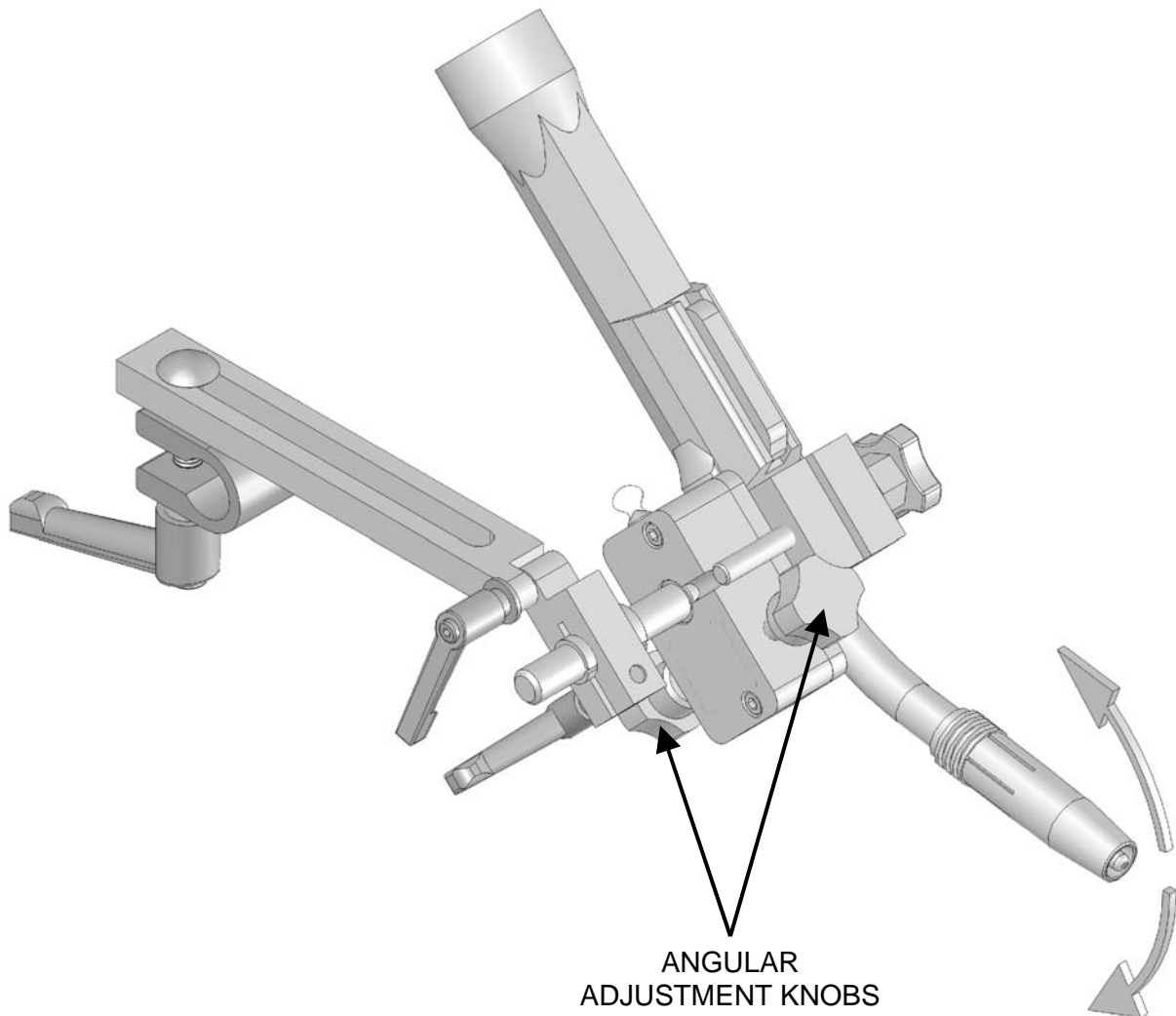

REVISIONS LIST

September, 2003

Overall Creation of manual.

October, 2003

Front Page Corrected typing error of model numbers.
Page 9 Changed subheading and first paragraph.

September, 2004

Overall Revised manual to reflect dedicated GSP chips programmed for Moggy's & revisions to standard and optional guide arm assemblies.

April, 2005

Page 14 Updated Moggy with Adjustable Guide Wheel Assembly image.

February, 2006

Title Page Updated Gullco India's e-mail address.
Page 15 Added GM-186-320 to the list of optional accessories.

March, 2007

Title Page Updated Gullco contact details.
Page 13 2 x GM-03-028-18 Extended Length Guide Arms now included with Radial Oscillator.

January, 2008

Title Page Updated Gullco contact details.

Sept, 2010

Title Page Updated Gullco contact details.
Page 3 Added operating temperature range of drive wheels.
Back page Updated back page.

ADDITIONAL NOTES

Specifications and products are subject to change without notice.
Kat, Moggy, Sam & KATBAK are registered trademarks of Gullco International Enterprises Ltd.
Only use genuine/authorized replacement parts.



GULLCO



LINEAR or RADIAL
HIGH DEPOSIT RATE
QUICK SETUP TIME

KAT[®] OSCILLATOR

- Motorized weld center line adjustment
- Motorized stroke width
- Oscillation speed control
- Store up to 10 welding programs

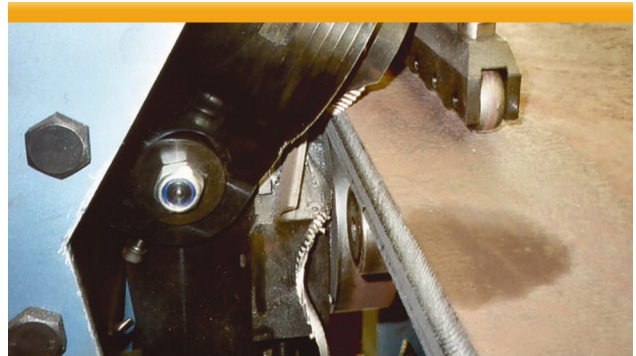

PORTABLE PLATE EDGE
BEVELLING MACHINE
QUICK SETUP TIME

KBM[®]

- Produce clean bevels with no thermal distortion
- Bevels angles 22° to 55° (other angles available)
- Hydraulic and Adjustable undercarriages available
- Bevels Mild Steel, Stainless Steel, and Aluminium
- Reduce cost and save time by minimising defects and poor fit up

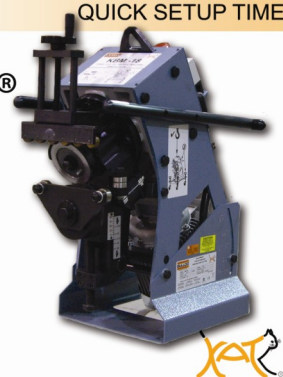

ONE SIDED WELDING
X-RAY QUALITY BEADS
HIGH DEPOSIT RATE

KATBAK[®] CERAMIC WELD BACKING

- Eliminate Defects And Rework
- Eliminate Costly Unnecessary Gouging And Grinding
- Sizes 1/4" (6.3 mm) to 2" (51 mm)
- Special Sizes And Configurations Available

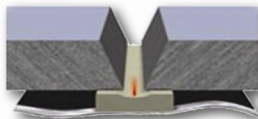

PORTABLE AND COMPACT
INCREASE EFFICIENCY
MORE ARC ON TIME

MOGGY[®] FILLET WELD CARRIAGE

- Single or Dual Torch Models
- Magnet or Non Magnetic Base
- Continuous or Stitch Welding Models
- Fillet, Lap, Butt and Dual Torch Welding

