

## FilterBox 10A

Automatically cleaned for light to medium dust & fume applications. W3 tested.



The FilterBox 10A is equipped with a N24 fan for a maximum air flow capacity of 1 000 m<sup>3</sup>/h (600 CFM). An integrated silencer reduces noise from the fan and outlet air.

The unit has an advanced filter control system with automatic cleaning that starts when the air flow is too low. Depending on the model, it is equipped with mechanical cleaning for dust applications or a combination of mechanical and compressed air cleaning for fumes and dust.

FilterBox 10A is available either as a mobile unit on wheels or attached to a floor stand. Additional protection from harmful particles is provided if a HEPA filter is installed.

For dust applications, the unit is cleaned mechanically. For welding fumes it uses a combination of mechanical and compressed air cleaning.

For welding applications, compressed air cleaning is required.









Note! FilterBox is not for use in environments where combustible dust or gases are present, and it is not for use in filtering combustible dust or gases.

- User friendly and superior filter cleaning, mechanical and/or with compressed air for long filter life
- Automatic damper preventing dust from leaking out while cleaning
- Dust free filter replacement and emptying of dust bin
- Third party approval for welding fumes category W3 according to EN 15012-1









<b>Product name</b>	FilterBox 10A
<b>Noise level (dB(A))</b>	66
<b>Filter efficiency (%)</b>	99
<b>Compressed air requirement</b>	DIN ISO 8573-1, class 5/5/4 (7 bar)
<b>Installation</b>	Indoor
<b>Material</b>	Casing in rotomoulded plastic
<b>Dustbin volume (l)</b>	15
<b>Extraction arm diameter (mm)</b>	160
<b>Airflow (m<sup>3</sup>/h)</b>	1000
<b>Filter Area (m<sup>2</sup>)</b>	13
<b>Filter type</b>	Cartridge
<b>Number of filter elements</b>	1
<b>Filter material</b>	Polyester PW13
<b>Electric plug</b>	Without
<b>Note</b>	Mechanical filter cleaning only











## FilterBox 10A

Image	Description	Power Voltage (V)	Frequency (Hz)	No of phases	Arm length (m)	Mounting	Weight (kg)	Filter cleaning method	Power (kW)	Model
	FilterBox 10 A.	230	50	3	3	Mobile	102	Mechanical	0,9	12653663*
	FilterBox 10 A.	230	50	3	3	Floor mounted	99	Mechanical	0,9	12653763*
	FilterBox 10 A.	400	50	3	3	Mobile	102	Mechanical	0,9	12653863*
	FilterBox 10 A.	400	50	3	3	Floor mounted	99	Mechanical	0,9	12653963*
	FilterBox 10 A	200	50	3	3	Mobile	102	Mechanical , Compressed air	0,9	12679163
	FilterBox 10 A	200	50	3	3	Floor mounted	99	Mechanical , Compressed air	0,9	12679263
	FilterBox 10 A.	200	60	3	3	Floor mounted	99	Mechanical	0,9	12657563*
	FilterBox 10 A.	120	60	1	3	Mobile	102	Mechanical	0,75	12657663*
	FilterBox 10 A.	230	60	3	3	Mobile	102	Mechanical	0,9	12656863*
	FilterBox 10 A.	230	60	3	3	Floor mounted	99	Mechanical	0,9	12656963*
	FilterBox 10 A.	460	60	3	3	Mobile	102	Mechanical	0,9	12657063*
	FilterBox 10 A.	460	60	3	3	Floor mounted	99	Mechanical	0,9	12657163*
	FilterBox 10 A.	575	60	3	3	Mobile	102	Mechanical	0,9	12657263*
	FilterBox 10 A.	575	60	3	3	Floor mounted	99	Mechanical	0,9	12657363*
	FilterBox 10 A.	200	60	3	3	Mobile	102	Mechanical	0,9	12657463*

## FilterBox 10A

Image	Description	Power Voltage (V)	Frequency (Hz)	No of phases	Arm length (m)	Mounting	Weight (kg)	Filter cleaning method	Power (kW)	Model
	FilterBox 10 A	230	50	3	3	Mobile	102	Mechanical ,Compressed air	0,9	12655263
	FilterBox 10 A	230	50	3	3	Floor mounted	99	Mechanical ,Compressed air	0,9	12655363
	FilterBox 10 A	400	50	3	3	Mobile	102	Mechanical ,Compressed air	0,9	12655463
	FilterBox 10 A	400	50	3	3	Floor mounted	99	Mechanical ,Compressed air	0,9	12655563
	FilterBox 10 A	230	50	1	3	Mobile	102	Mechanical ,Compressed air	0,75	12655663
	FilterBox 10 A	230	50	1	3	Floor mounted	99	Mechanical ,Compressed air	0,75	12655763
	FilterBox 10 A	110	50	1	3	Mobile	102	Mechanical ,Compressed air	0,75	12655863
	FilterBox 10 A	230	50	1	3	Floor mounted	99	Mechanical ,Compressed air	0,75	12655963
	FilterBox 10 A.	120	60	1	3	Floor mounted	99	Mechanical	0,75	12657763*
	FilterBox 10 A	575	60	3	3	Floor mounted	99	Mechanical ,Compressed air	0,9	12658363
	FilterBox 10 A.	230	50	1	3	Mobile	102	Mechanical	0,75	12654063*
	FilterBox 10 A.	230	50	1	3	Floor mounted	99	Mechanical	0,75	12654163*
	FilterBox 10 A.	110	50	1	3	Mobile	102	Mechanical	0,75	12654263*
	FilterBox 10 A.	110	50	1	3	Floor mounted	99	Mechanical	0,75	12654363*
	FilterBox 10 A.	230	60	1	3	Mobile	102	Mechanical	0,75	12681563*

## FilterBox 10A











Image	Description	Power Voltage (V)	Frequency (Hz)	No of phases	Arm length (m)	Mounting	Weight (kg)	Filter cleaning method	Power (kW)	Model
	FilterBox 10 A.	230	60	1	3	Floor mounted	99	Mechanical	0,75	12681663*
	FilterBox 10 A	230	60	3	3	Mobile	102	Mechanical ,Compressed air	0,9	12657863
	FilterBox 10 A	230	60	3	3	Floor mounted	99	Mechanical ,Compressed air	0,9	12657963
	FilterBox 10 A	460	60	3	3	Mobile	102	Mechanical ,Compressed air	0,9	12658063
	FilterBox 10 A	460	60	3	3	Floor mounted	99	Mechanical ,Compressed air	0,9	12658163
	FilterBox 10 A	575	60	3	3	Mobile	102	Mechanical ,Compressed air	0,9	12658263
	FilterBox 10 A	200	60	3	3	Mobile	102	Mechanical ,Compressed air	0,9	12658463
	FilterBox 10 A	200	60	3	3	Floor mounted	99	Mechanical ,Compressed air	0,9	12658563
	FilterBox 10 A	230	60	1	3	Mobile	102	Mechanical ,Compressed air	0,75	12681763
	FilterBox 10 A	230	60	1	3	Floor mounted	99	Mechanical ,Compressed air	0,75	12681863
	FilterBox 10 A	120	60	1	3	Mobile	102	Mechanical ,Compressed air	0,75	12658663
	FilterBox 10 A.	400	50	3	Without	Floor mounted	99	Mechanical	0,9	12686263*
	FilterBox 10 A	120	60	1	3	Floor mounted	99	Mechanical ,Compressed air	0,75	12658763
	FilterBox 10 A	400	50	3	Without	Floor mounted	99	Mechanical ,Compressed air	0,9	12685063
	FilterBox 10 A	400	50	3	Without	Mobile	102	Mechanical ,Compressed air	0,9	12686763

## FilterBox 10A

Image	Description	Power Voltage (V)	Frequency (Hz)	No of phases	Arm length (m)	Mounting	Weight (kg)	Filter cleaning method	Power (kW)	Model
	FilterBox 10 A	380	60	3	3	Mobile	102	Mechanical , Compressed air	0,75	12689263
	FilterBox 10 A.	400	50	3	Without	Mobile	102	Mechanical	0,9	12686863*

\*Mechanical filter cleaning only

## FilterBox 10A

	Accessory	Part No
	Outlet with duct connection D=200mm	12376749
	Spotlight original, (LED) 24V, 5W	12376616*
	Spark protection for Original/NEX MD-hood	10551335
	LED light/fan switch Original	10376922
	Filter-PW-FB-13	12332672
	Filter-PW HE-FB-15	12371106
	Filter PWA-FB-15	12371412
	HEPA filter H13 10m2 Filterbox	12376615
	Bags for Filterbox dust bin, 10pcs	12376618
	HEPA filter H14 10m2 Filterbox	12376756
	Sensor clamp to be attached to the earth cable of the welding power source.	14372199
	Twin Module blue	12376801

\*Switch for light (no fan start)

## FilterBox 10A

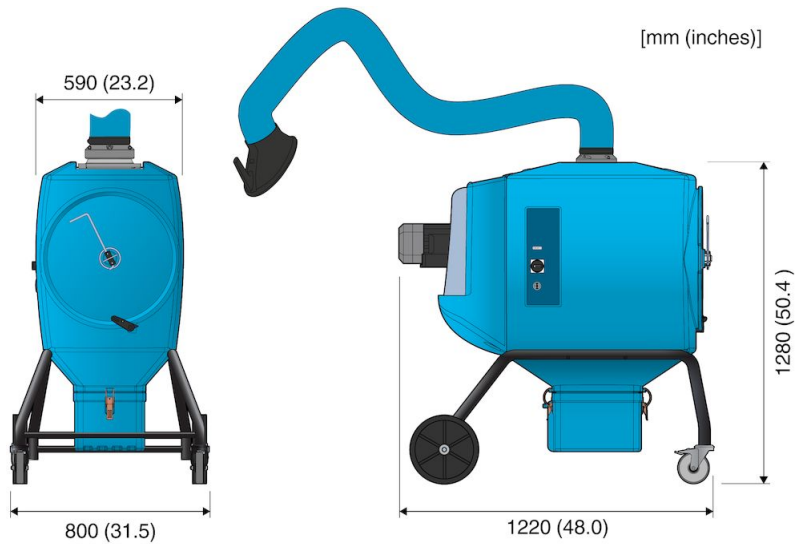

FilterBox 10A mobile

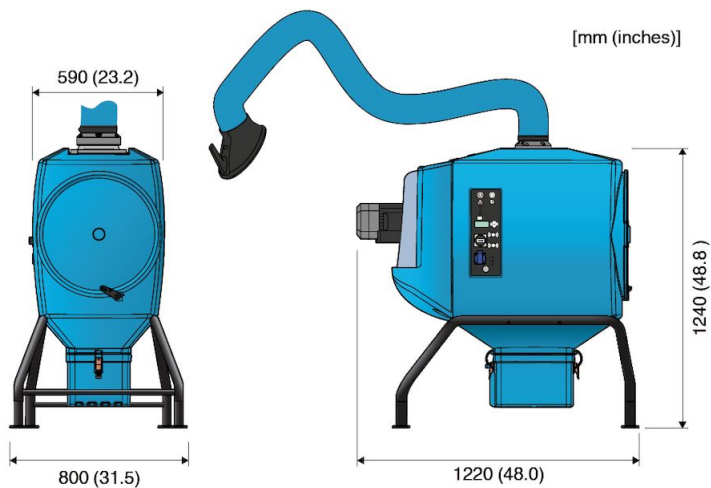

Floor mounted FilterBox 10A

FilterBox 10A Floor