

## FilterBox 12M

Manually cleaned for heavier dust & fume applications.



The FilterBox 12M is equipped with a powerful fan for a maximum air flow capacity of 1 200 m<sup>3</sup>/h (700 CFM). An integrated silencer reduces noise from the fan and outlet air.

The filter cartridge is manually cleaned. There is an alarm indicating when the air flow is too low, as well as an operating hours meter.

The unit is available either as a mobile unit on wheels or attached to a floor stand. Additional protection from harmful particles is provided if a HEPA filter is installed.

For dust applications, the unit is cleaned mechanically. For welding fumes it uses a combination of mechanical and compressed air cleaning.

For welding applications, compressed air cleaning is required.











Note! FilterBox is not for use in environments where combustible dust or gases are present, and it is not for use in filtering combustible dust or gases.

- User friendly and superior filter cleaning, mechanical and/or with compressed air for long filter life
- Automatic damper preventing dust from leaking out while cleaning
- Dust free filter replacement and emptying of dust bin
- Third party approval for welding fumes category W3 according to EN 15012-1









|                                     |                                     |
|-------------------------------------|-------------------------------------|
| <b>Product name</b>                 | FilterBox 12M                       |
| <b>Noise level (dB(A))</b>          | 74                                  |
| <b>Filter efficiency (%)</b>        | 99                                  |
| <b>Compressed air requirement</b>   | DIN ISO 8573-1, class 5/5/4 (7 bar) |
| <b>Installation</b>                 | Indoor                              |
| <b>Material</b>                     | Casing in rotomoulded plastic       |
| <b>Dustbin volume (l)</b>           | 15                                  |
| <b>Extraction arm diameter (mm)</b> | 160                                 |
| <b>Airflow (m<sup>3</sup>/h)</b>    | 1200                                |
| <b>Filter Area (m<sup>2</sup>)</b>  | 13                                  |
| <b>Filter type</b>                  | Cartridge                           |
| <b>Number of filter elements</b>    | 1                                   |
| <b>Electric plug</b>                | Without                             |
| <b>Power (kW)</b>                   | 2,2                                 |
| <b>Note</b>                         | Mechanical filter cleaning only     |



# FilterBox 12M











| Image   | Description   | Power Voltage (V) | Frequency (Hz) | No of phases | Arm length (m) | Filter material | Mounting      | Weight (kg) | Filter cleaning method     | Model     |
|---|---------------|-------------------|----------------|--------------|----------------|-----------------|---------------|-------------|----------------------------|-----------|
|   | FilterBox 12M | 400               | 50             | 3            | 3 (Original)   | Polyester PW13  | Mobile        | 115         | Mechanical                 | 12660163* |
|   | FilterBox 12M | 230               | 50             | 3            | 3 (Original)   | Polyester PW13  | Mobile        | 115         | Mechanical                 | 12659963* |
|   | FilterBox 12M | 230               | 50             | 3            | 3 (Original)   | Polyester PW13  | Mobile        | 115         | Mechanical ,Compressed air | 12660363  |
|    | FilterBox 12M | 230               | 50             | 3            | 3 (Original)   | Polyester PW13  | Floor mounted | 112         | Mechanical ,Compressed air | 12660463  |
|    | FilterBox 12M | 230               | 50             | 3            | 3 (Original)   | Polyester PW14  | Floor mounted | 112         | Mechanical                 | 12660063  |
|   | FilterBox 12M | 400               | 50             | 3            | 3 (Original)   | Polyester PW13  | Floor mounted | 112         | Mechanical ,Compressed air | 12660663  |
|  | FilterBox 12M | 400               | 50             | 3            | 3 (Original)   | Polyester PW15  | Floor mounted |             | Mechanical                 | 12660263  |
|   | FilterBox 12M | 400               | 50             | 3            | 3 (Original)   | Polyester PW13  | Mobile        | 115         | Mechanical ,Compressed air | 12660563  |
|  | FilterBox 12M | 230               | 60             | 3            | 3 (NEX MD)     | Polyester PW13  | Mobile        | 115         | Mechanical ,Compressed air | 12660963  |
|  | FilterBox 12M | 230               | 60             | 3            | 3 (NEX MD)     | Polyester PW13  | Floor mounted | 112         | Mechanical ,Compressed air | 12661063  |
|  | FilterBox 12M | 460               | 60             | 3            | 3 (NEX MD)     | Polyester PW13  | Mobile        | 115         | Mechanical ,Compressed air | 12661163  |
|  | FilterBox 12M | 460               | 60             | 3            | 3 (NEX MD)     | Polyester PW13  | Floor mounted | 112         | Mechanical ,Compressed air | 12661263  |
|  | FilterBox 12M | 575               | 60             | 3            | 3 (NEX MD)     | Polyester PW13  | Mobile        | 115         | Mechanical ,Compressed air | 12661363  |
|  | FilterBox 12M | 575               | 60             | 3            | 3 (NEX MD)     | Polyester PW13  | Floor mounted | 112         | Mechanical ,Compressed air | 12661463  |
|  | FilterBox 12M | 230               | 60             | 1            | 3 (NEX MD)     | Polyester PW13  | Mobile        | 115         | Mechanical ,Compressed air | 12683763  |

## FilterBox 12M

| Image   | Description    | Power Voltage (V) | Frequency (Hz) | No of phases | Arm length (m) | Filter material | Mounting      | Weight (kg) | Filter cleaning method     | Model     |
|---|----------------|-------------------|----------------|--------------|----------------|-----------------|---------------|-------------|----------------------------|-----------|
|    | FilterBox 12M  | 230               | 60             | 1            | 3 (NEX MD)     | Polyester PW13  | Floor mounted | 112         | Mechanical ,Compressed air | 12683863  |
|   | FilterBox 12M  | 200               | 50             | 3            | 3 (Original)   | Polyester PW13  | Mobile        | 115         | Mechanical ,Compressed air | 12660763  |
|    | FilterBox 12M  | 120               | 60             | 1            | 3 (NEX MD)     | Polyester PW13  | Mobile        | 115         | Mechanical ,Compressed air | 12661763  |
|    | FilterBox 12M  | 120               | 60             | 1            | 3 (NEX MD)     | Polyester PW13  | Floor mounted | 112         | Mechanical ,Compressed air | 12661863  |
|    | FilterBox 12M  | 200               | 50             | 3            | 3 (Original)   | Polyester PW13  | Floor mounted | 112         | Mechanical ,Compressed air | 12660863  |
|   | FilterBox 12M  | 200               | 60             | 3            | 3 (Original)   | Polyester PW13  | Mobile        | 115         | Mechanical ,Compressed air | 12661563  |
|  | FilterBox 12M  | 200               | 60             | 3            | 3 (Original)   | Polyester PW13  | Floor mounted | 112         | Mechanical ,Compressed air | 12661663  |
|  | FilterBox 12M. | 400               | 50             | 3            | Without        | Polyester PW13  | Floor mounted | 112         | Mechanical                 | 12686363* |
|  | FilterBox 12M. | 400               | 50             | 3            | Without        | Polyester PW13  | Mobile        | 115         | Mechanical ,Compressed air | 12686963  |
|  | FilterBox 12M. | 400               | 50             | 3            | Without        | Polyester PW13  | Mobile        | 115         | Mechanical                 | 12687063* |
|  | FilterBox 12M. | 400               | 50             | 3            | Without        | Polyester PW13  | Floor mounted | 112         | Mechanical ,Compressed air | 12685163  |

\*Mechanical filter cleaning only

## FilterBox 12M

| Accessory   |   | Part No   |
|---|---|-----------|
|    | Spotlight original, (LED) 24V, 5W         | 12376616* |
|    | Handle eQ Filterbox                       | 12376617  |
|    | Outlet with duct connection D=200mm       | 12376749  |
|   | Upgrade for motor cleaning                | 12373614  |
|    | Spark protection for Original/NEX MD-hood | 10551335  |
|    | Filter-PW-FB-13                           | 12332672  |
|    | Filter-PW HE-FB-15                        | 12371106  |
|   | Filter PWA-FB-15                          | 12371412  |
|  | HEPA filter H13 10m2 Filterbox            | 12376615  |
|  | HEPA filter H14 10m2 Filterbox            | 12376756  |
|  | Bags for Filterbox dust bin, 10pcs        | 12376618  |
|   | Twin Module blue                          | 12376801  |

\*Switch for light (no fan start)

## FilterBox 12M

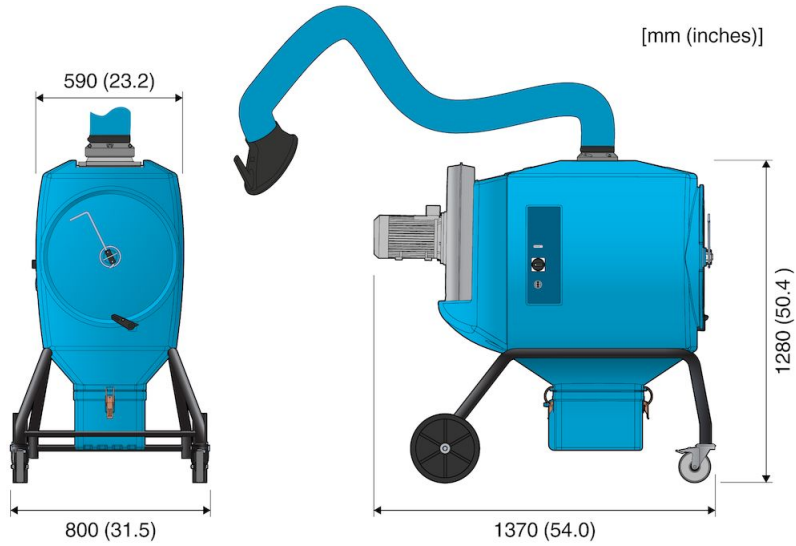

FilterBox 12M. Mobile

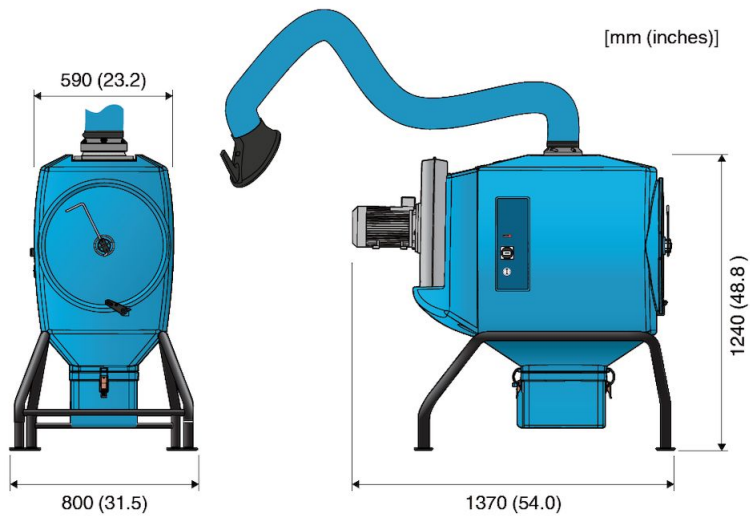

Floor mounted FilterBox 12M