

## UHP-2 CLOSED CHAMBER WELD HEADS

*TIG / GTAW welding of tube to tube joints*



*UHP 1500-2 with removable clamping cassette and flexible Tube Clamp Inserts TCI's™*

- Fusion TIG / GTAW all position orbital welding of tubes, fittings and accessories. O.D. from 1,6 mm / 1/16" to 33,7 mm / 1 1/3".
- Perfectly adapted for joining tubes out of stainless steel, high alloy materials and titanium.
- The head clamps on both sides of the weld joint and forms a closed chamber for the shielding gas and the welding arc.
- During welding, the head body remains stationary, the electrode gear and tungsten electrode rotate around the tube.



*PS type power source ideal for use with UHP weld heads*

*A modular concept*



Clamping cassette or TCI's™ per Ø

Electrode gear module  
 UHP 250-2: 1/4"  
 UHP 500-2: 1/2"  
 UHP 1500-2: 1 1/3"

A single drive

### UNIQUE FEATURES

- Compatible for work with all series of Polysoude power sources.
- High purity gas circuit to avoid particle emission and oxidation.
- Modular concept :
  - unique drive handle
  - three electrode gear modules 1/4" ; 1/2" ; 1 1/3"
  - removable clamping cassettes.
- Non symmetrical design for welding of fittings with short stick-out.
- Titanium clamping cassettes (UHP 250-2 and 500-2) or flexible Tube Clamp Inserts – TCI's™ (UHP 1500-2) to comply with standard O.D.'s tolerances and hygienic / high purity requirements.
- Narrow weld head profile for use in areas with constrained radial and axial clearance.
- Closed loop regulation to ensure precise, constant or pulsed welding speed.
- Encoder for position based control of the welding program.
- Return-to-home feature: the electrode gear automatically returns to its loading position.

### ACCESSORIES & OPTIONS for your particular needs

- Titanium clamping cassettes and Tube Clamp Inserts – TCI's™ for all tube and pipe O.D.'s available both in metric and inch sizes.
- Removable Fixture-Blocks for all types of micro-fittings, providing perfect tube end centring, alignments and great clamping force (UHP 500-2).
- Interchangeable electrode gear modules 1/4" ; 1/2" ; 1 1/3" for optimised use of axial and radial clearance around the weld joint.
- Extension cable (15 m).
- Manual tack welding kit including water-cooled TIG / GTAW torch.
- Dual weld head switch box.
- Compact brief-case for packing, transport and storage.
- Tungsten electrodes, pre-sharpened and pre-cut.
- Tool kit for daily operations.



*UHP 250-2 with clamping cassette*



*UHP 500-2 with clamping cassette*

**UHP-2 CLOSED CHAMBER WELD HEADS**

**WELD HEAD SPECIFICATION**

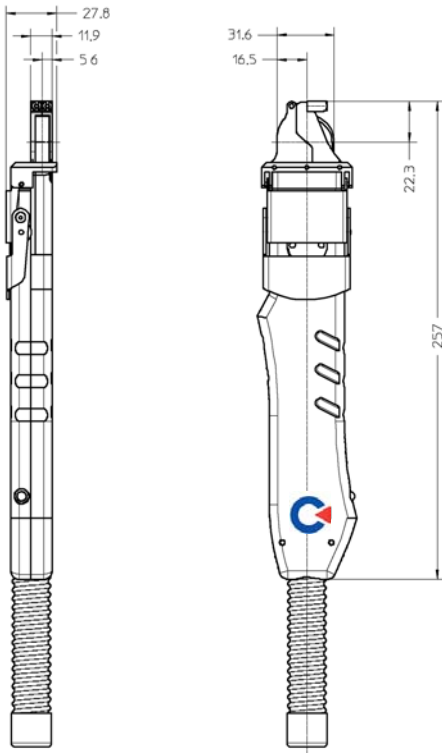

**UHP 250-2**

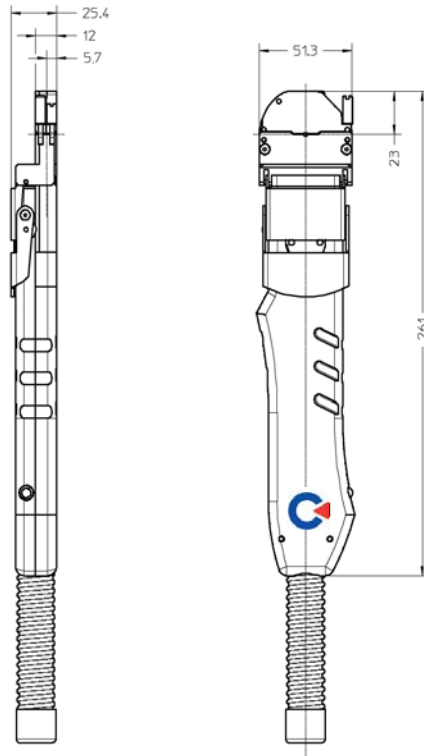

**UHP 500-2**

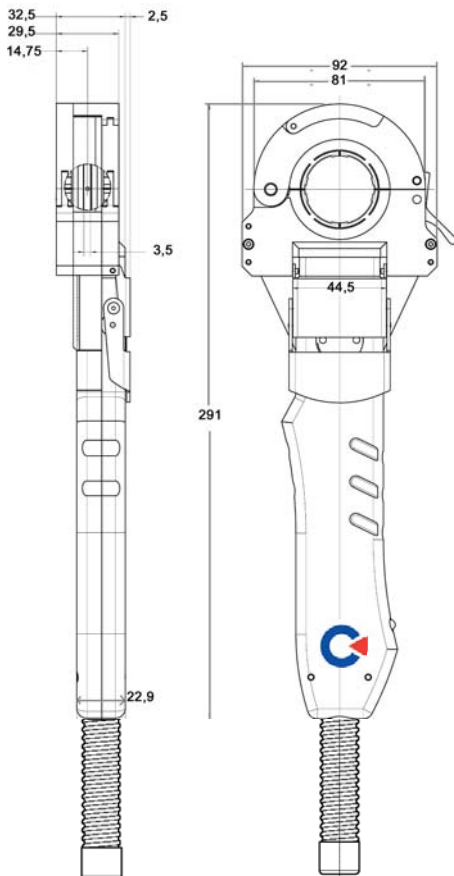

**UHP 1500-2**

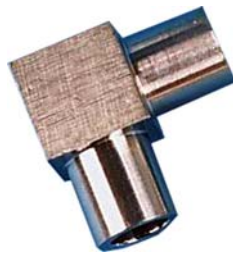

Reducing elbow



Fixture-Block for UHP 500-2



Union tee

*Removable Fixture-Blocks for all types of micro-fittings, providing perfect tube end centring, alignments and great clamping force (UHP 500-2)*

Cable length : 5,5 m

Type	Tube O.D. mm / inches	
	from - to	
<b>UHP 250-2</b>	1,60 – 6,35 mm	$\frac{1}{16}$ " – $\frac{1}{4}$ "
<b>UHP 500-2</b>	3,00 – 12,70 mm	$\frac{1}{8}$ " – $\frac{1}{2}$ "
<b>UHP 1500-2</b>	6,00 – 33,70 mm	$\frac{1}{4}$ " – $1\frac{1}{3}$ "